

1

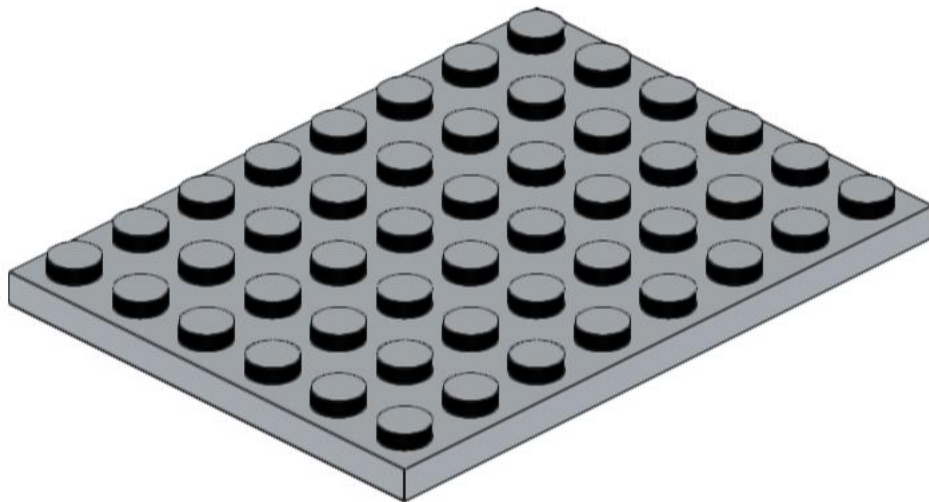

2

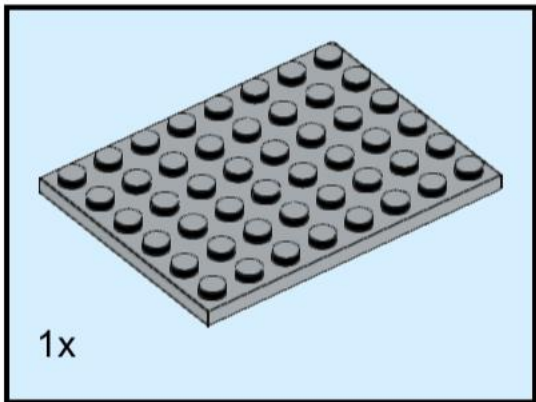
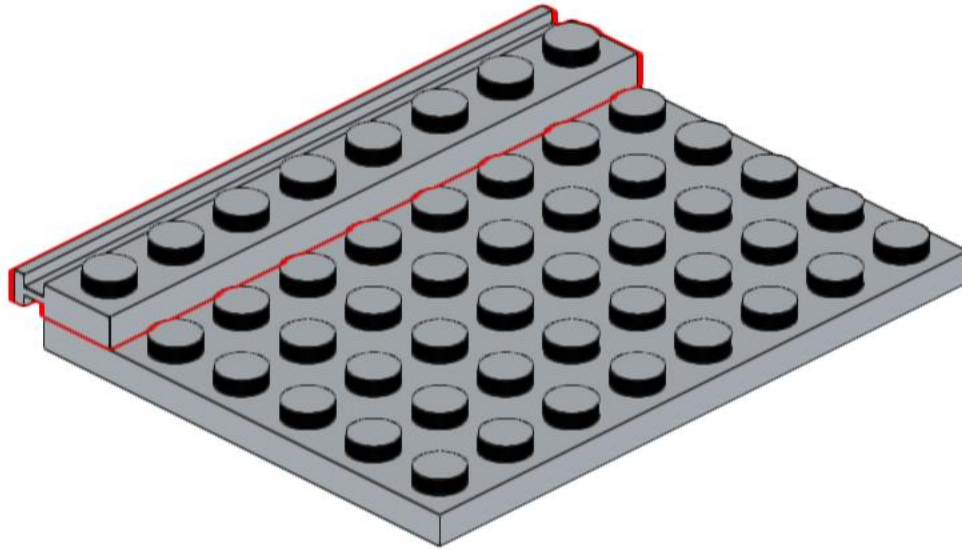
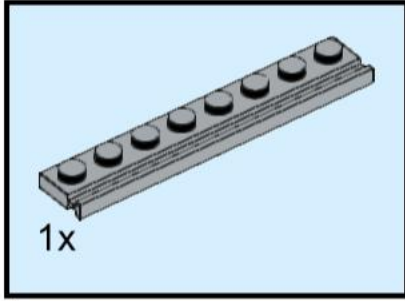

3

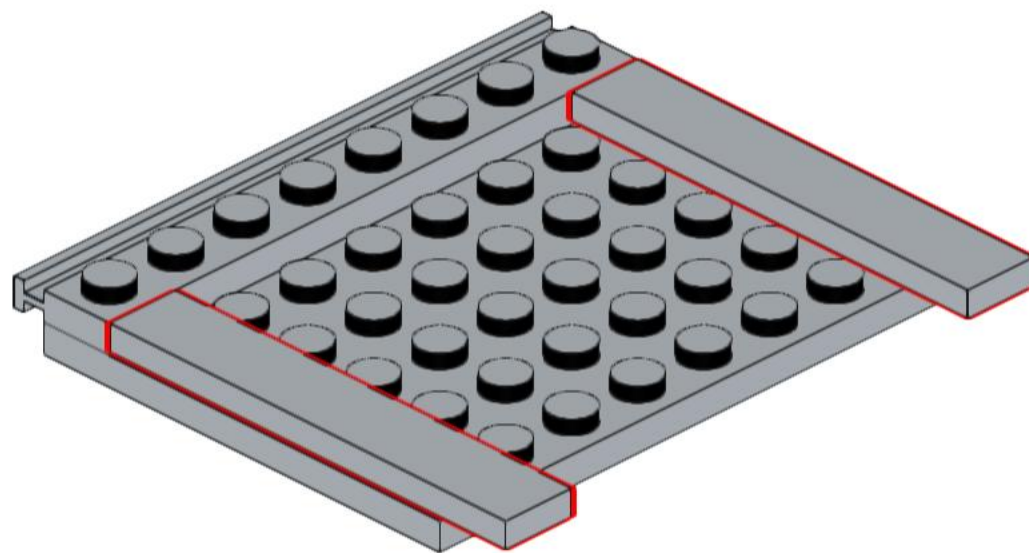
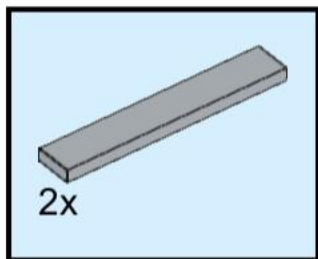

4

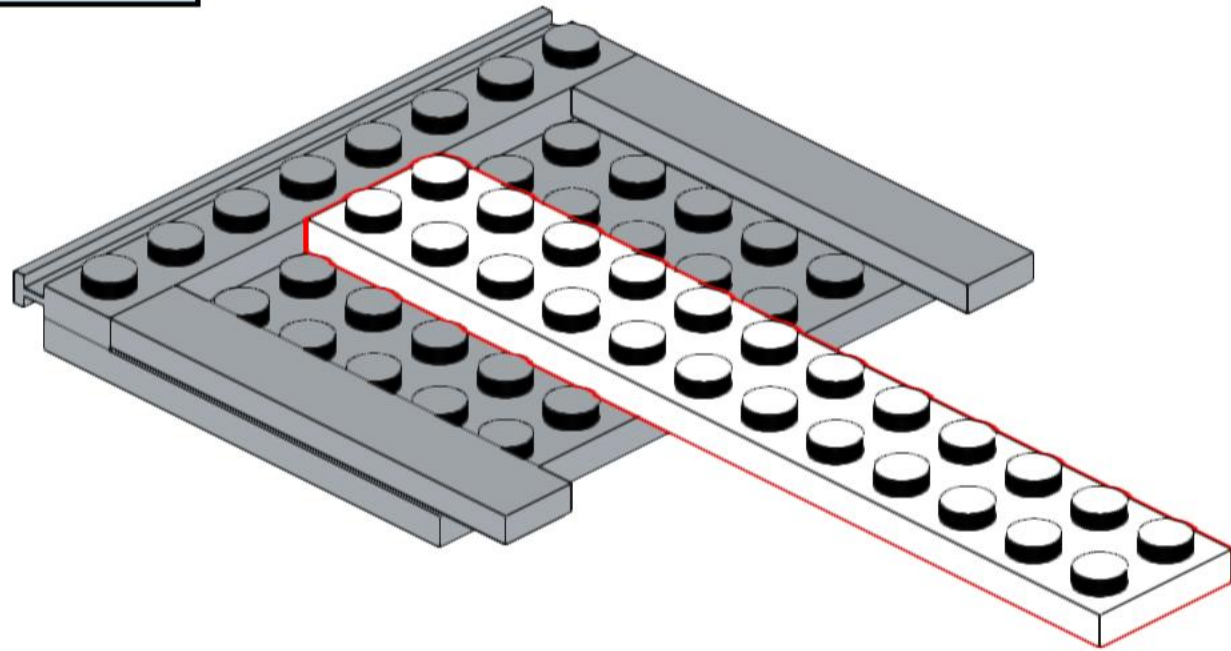
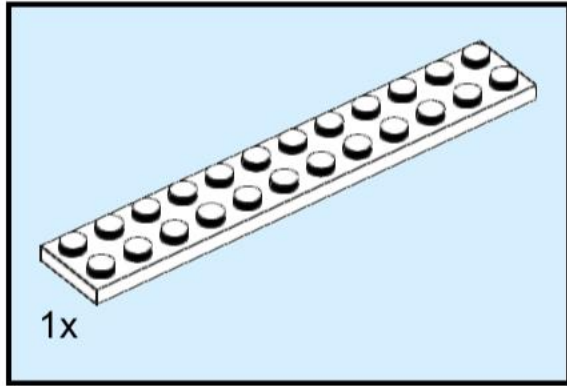

5

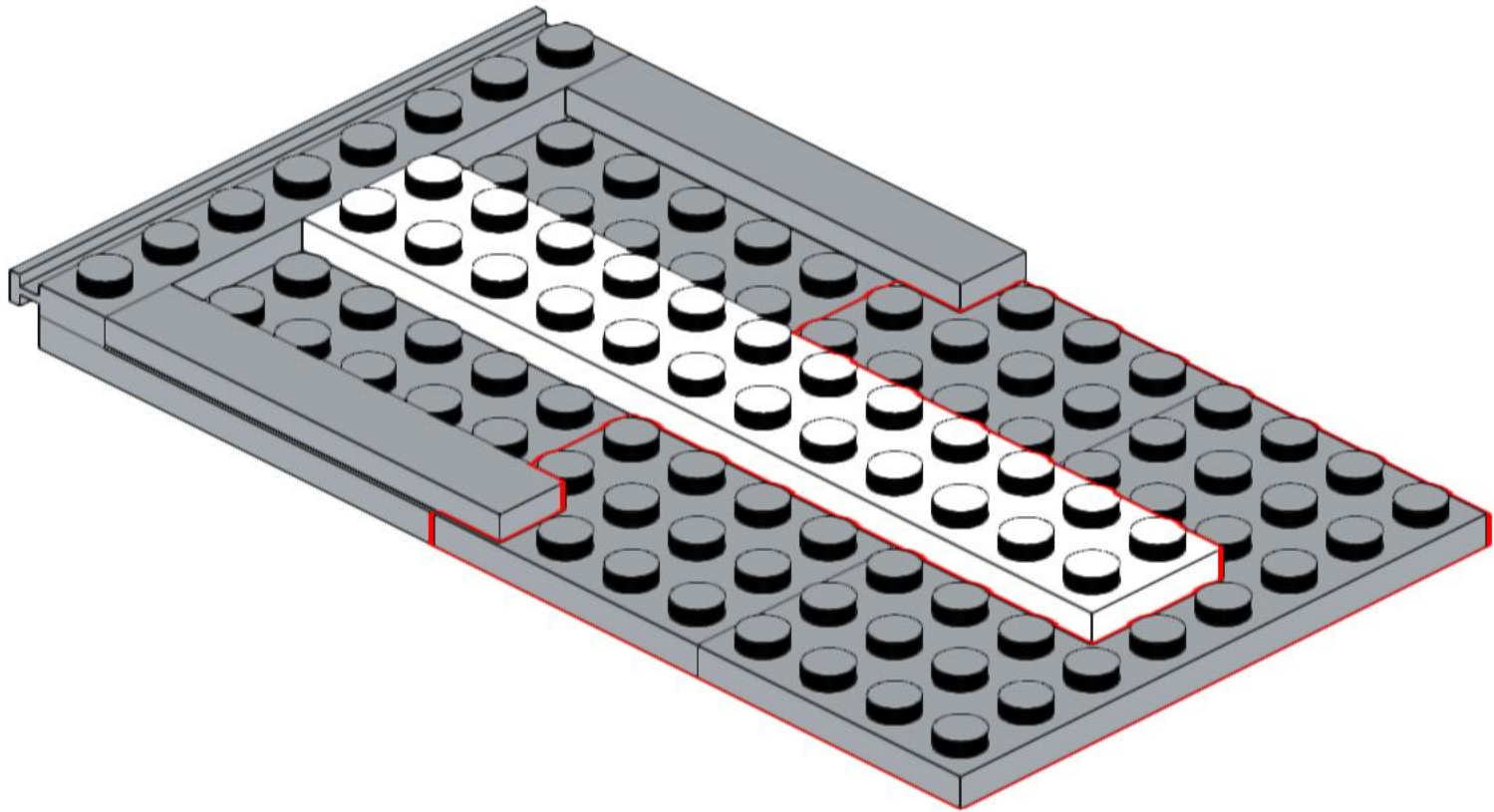
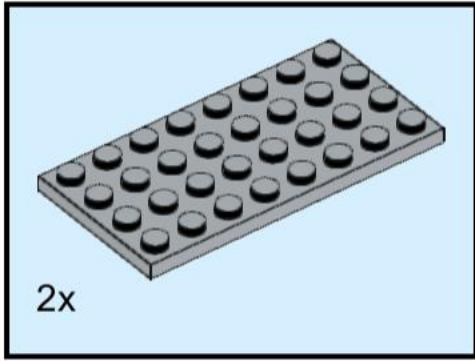

6

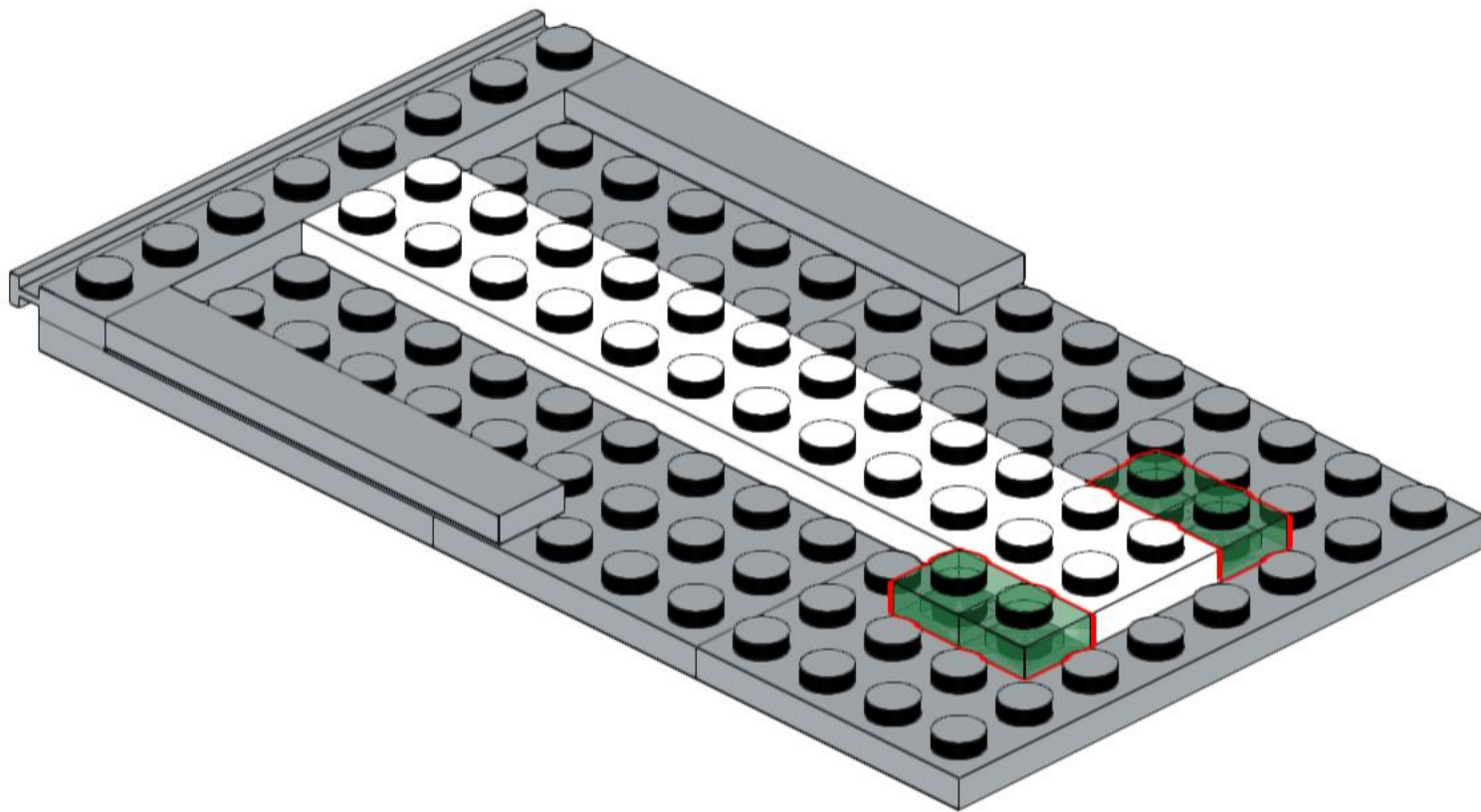
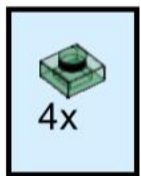

7

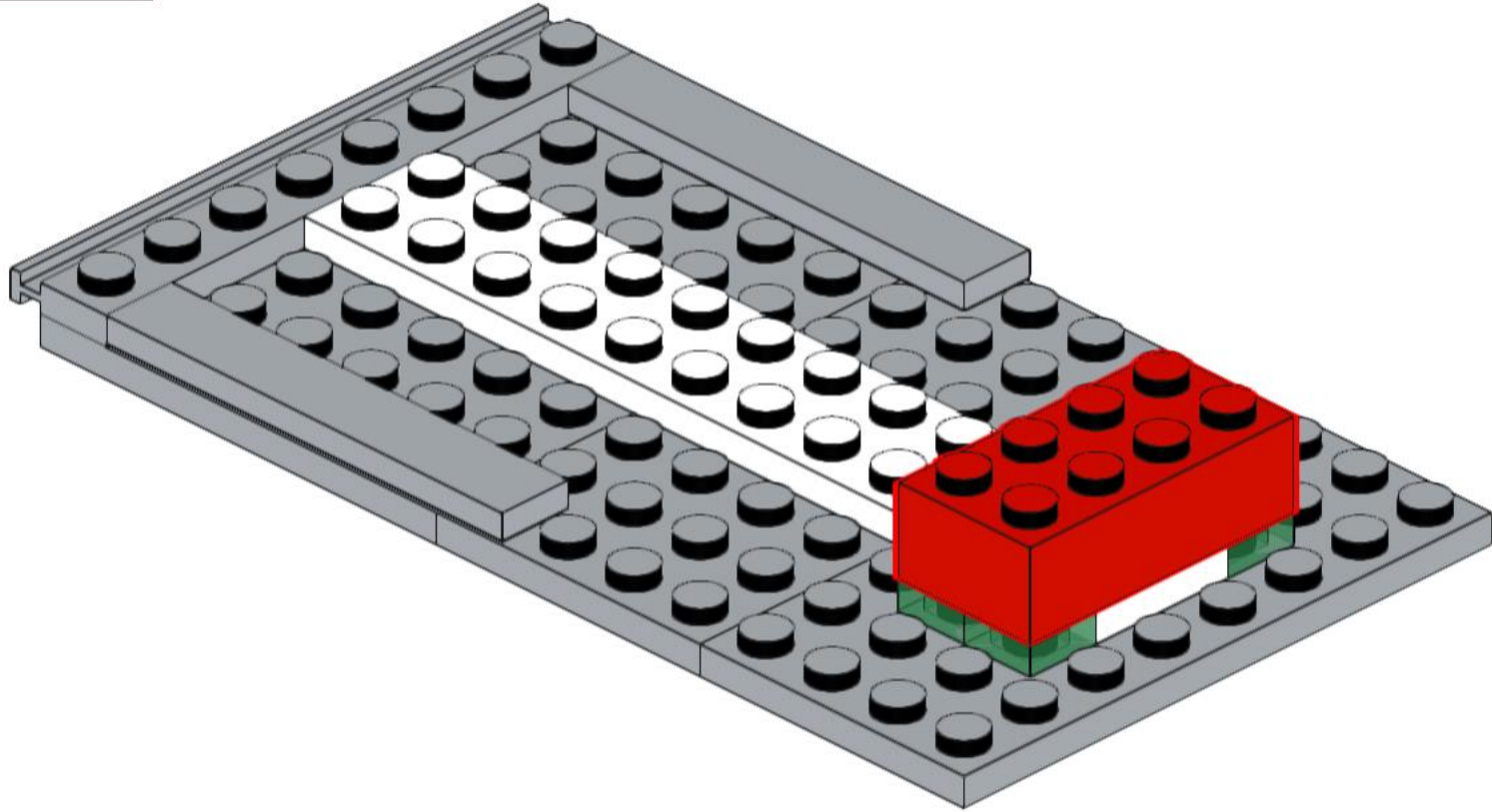
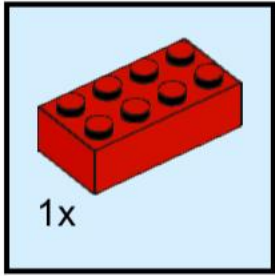

8

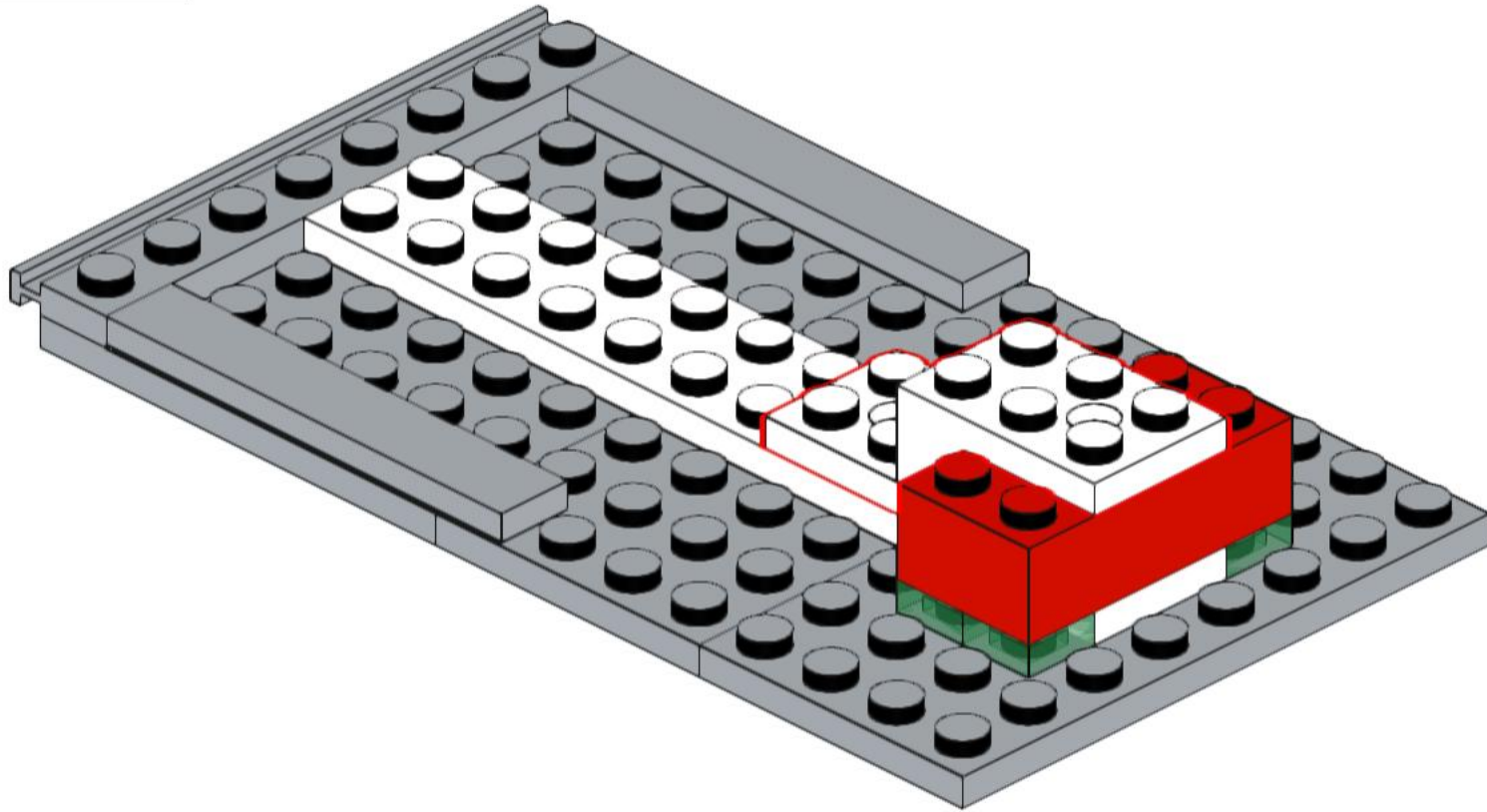
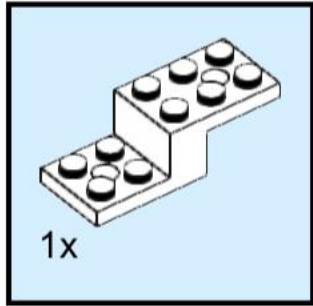

9

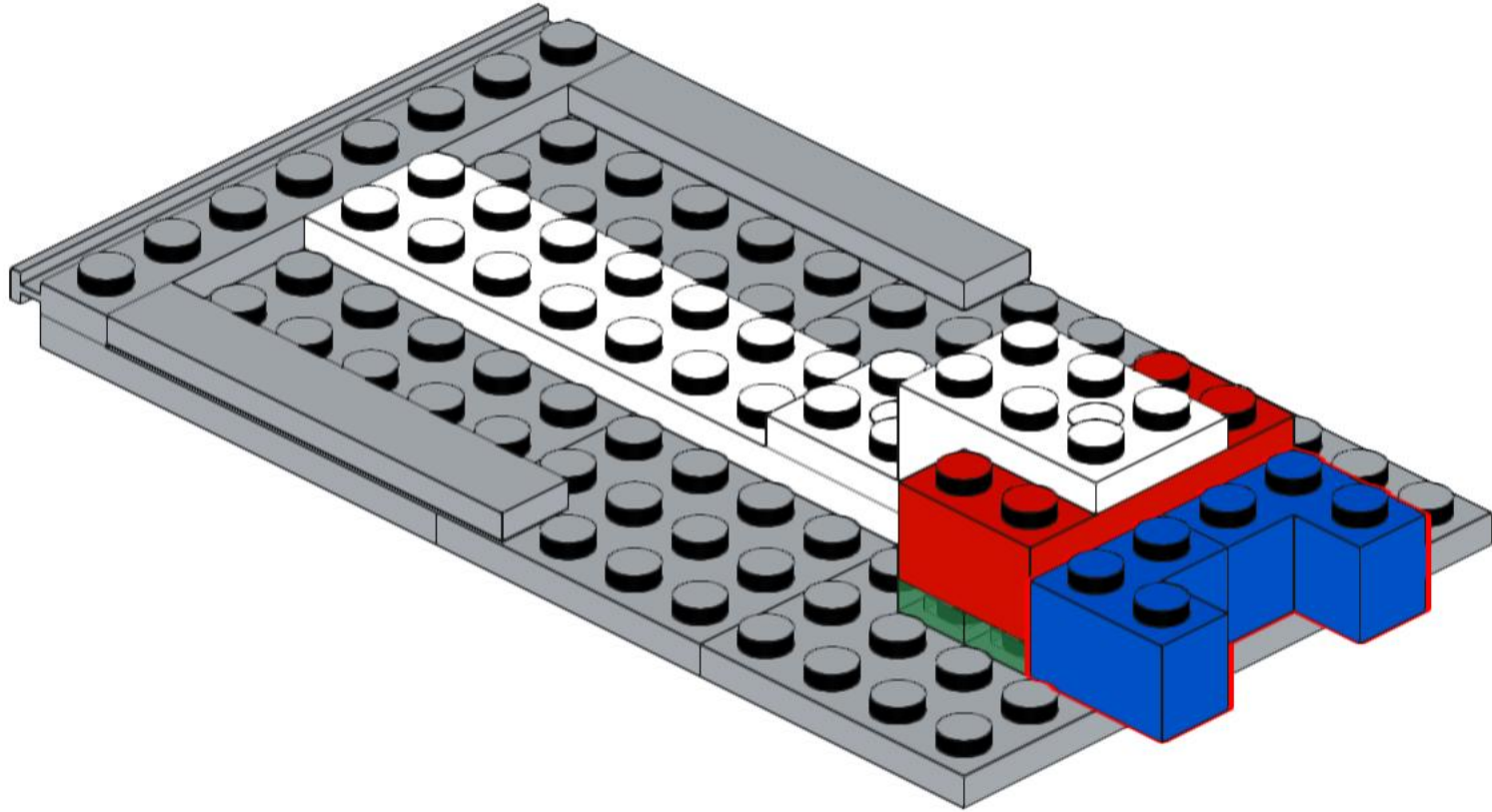
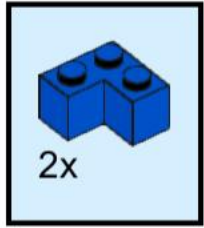

10

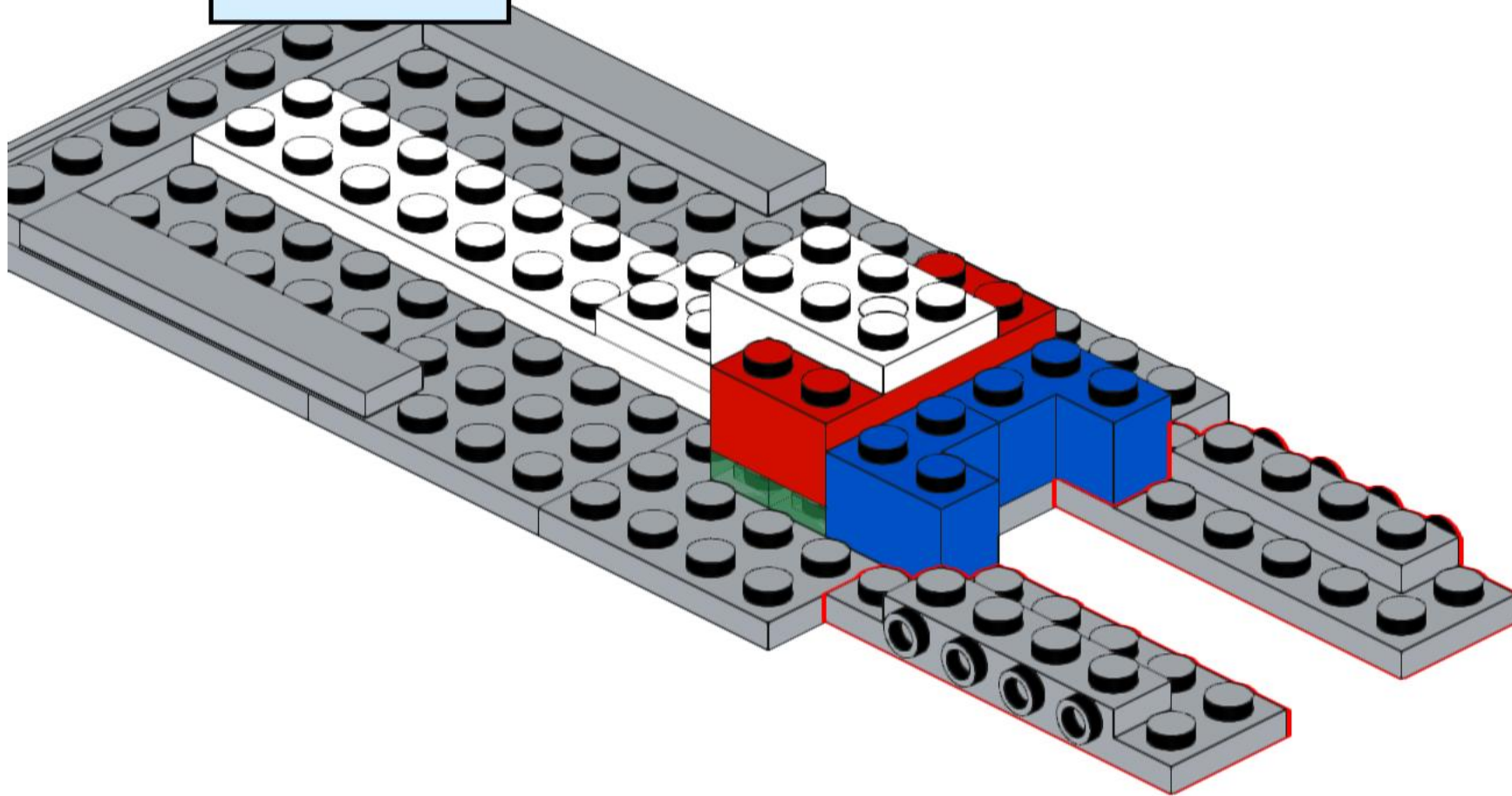
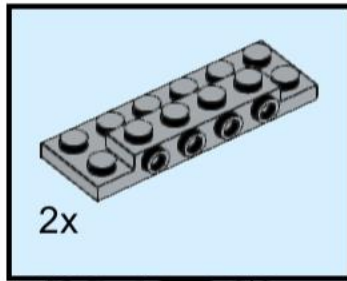

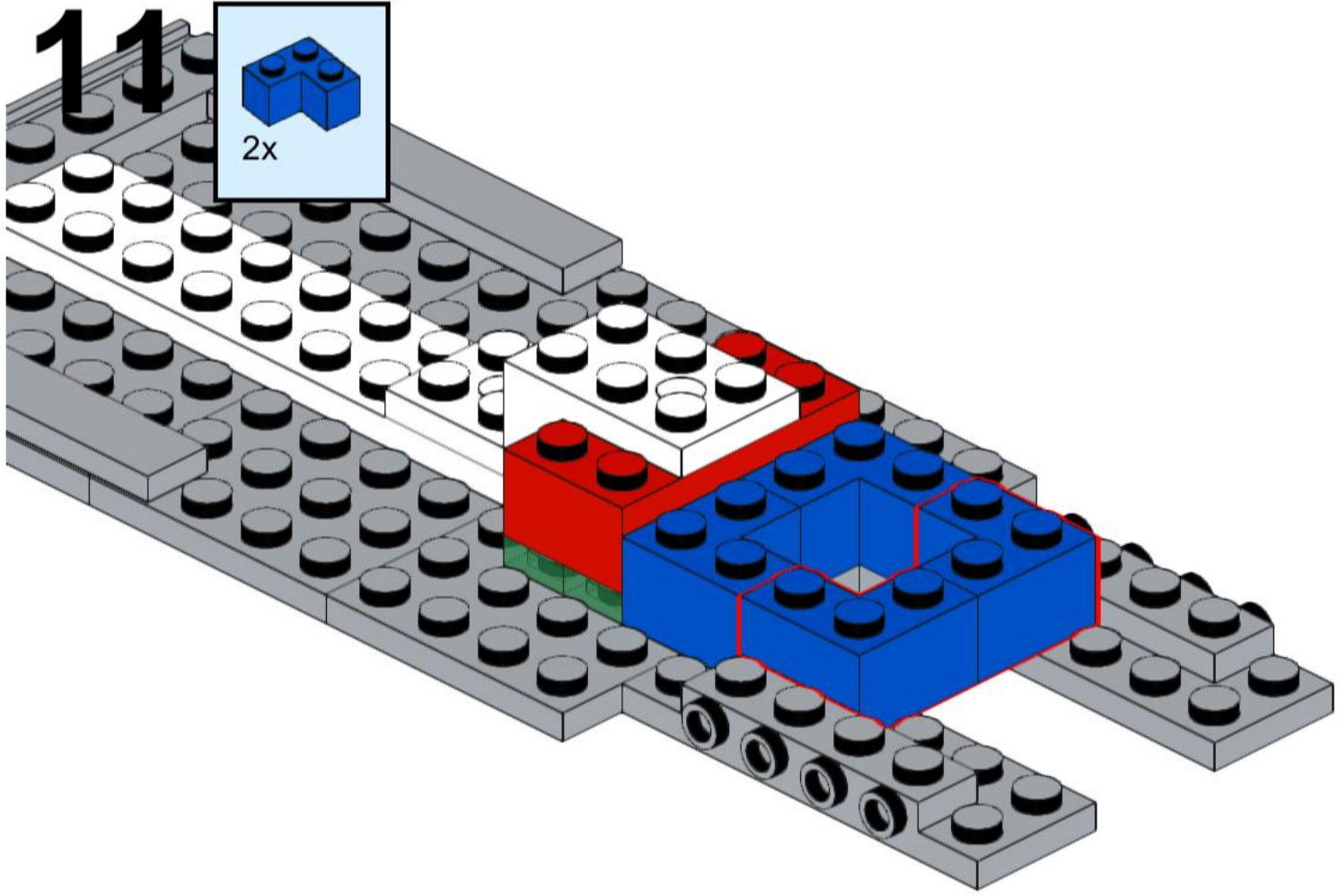

12

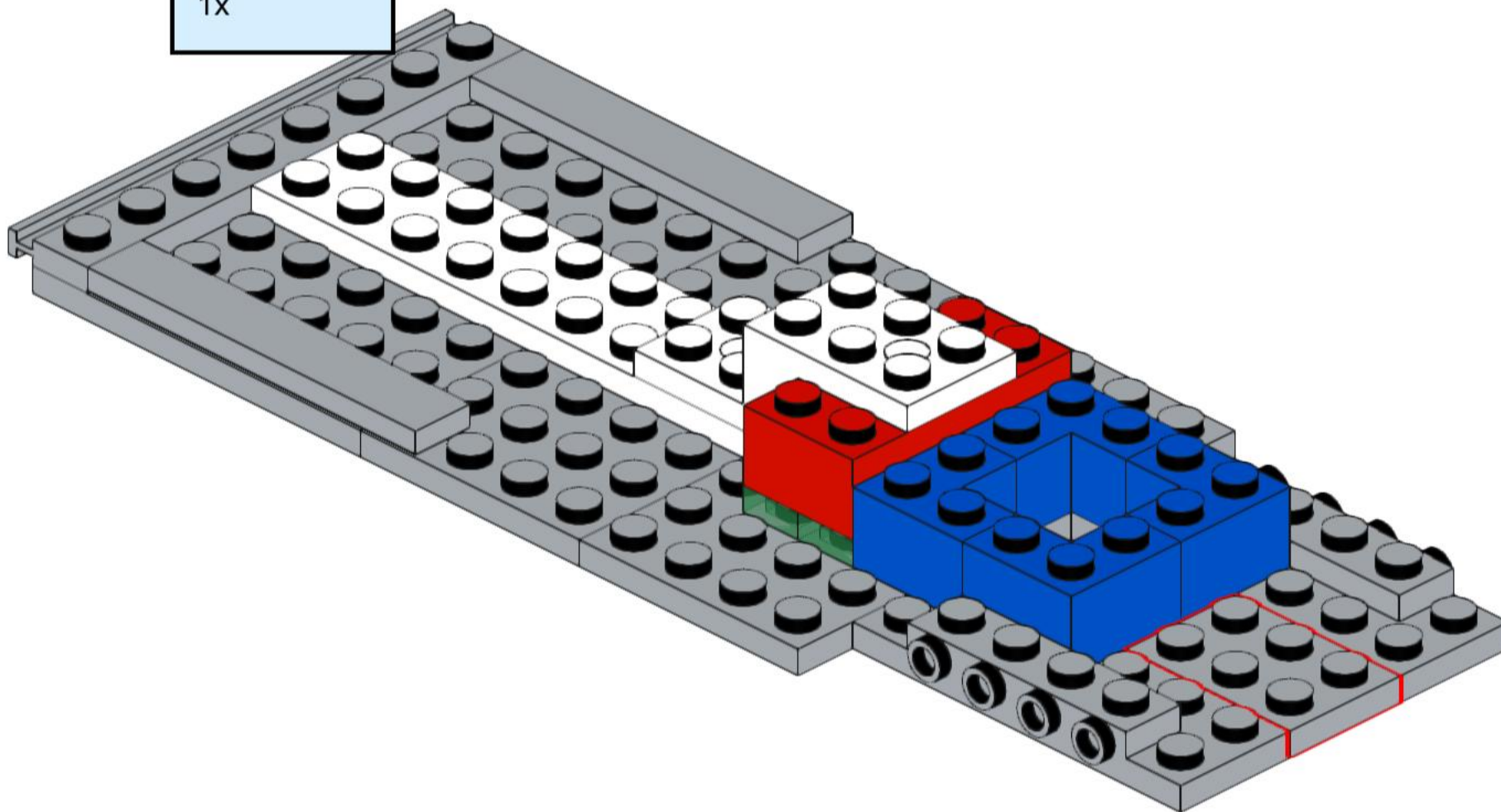
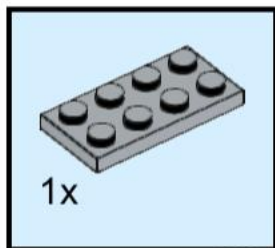

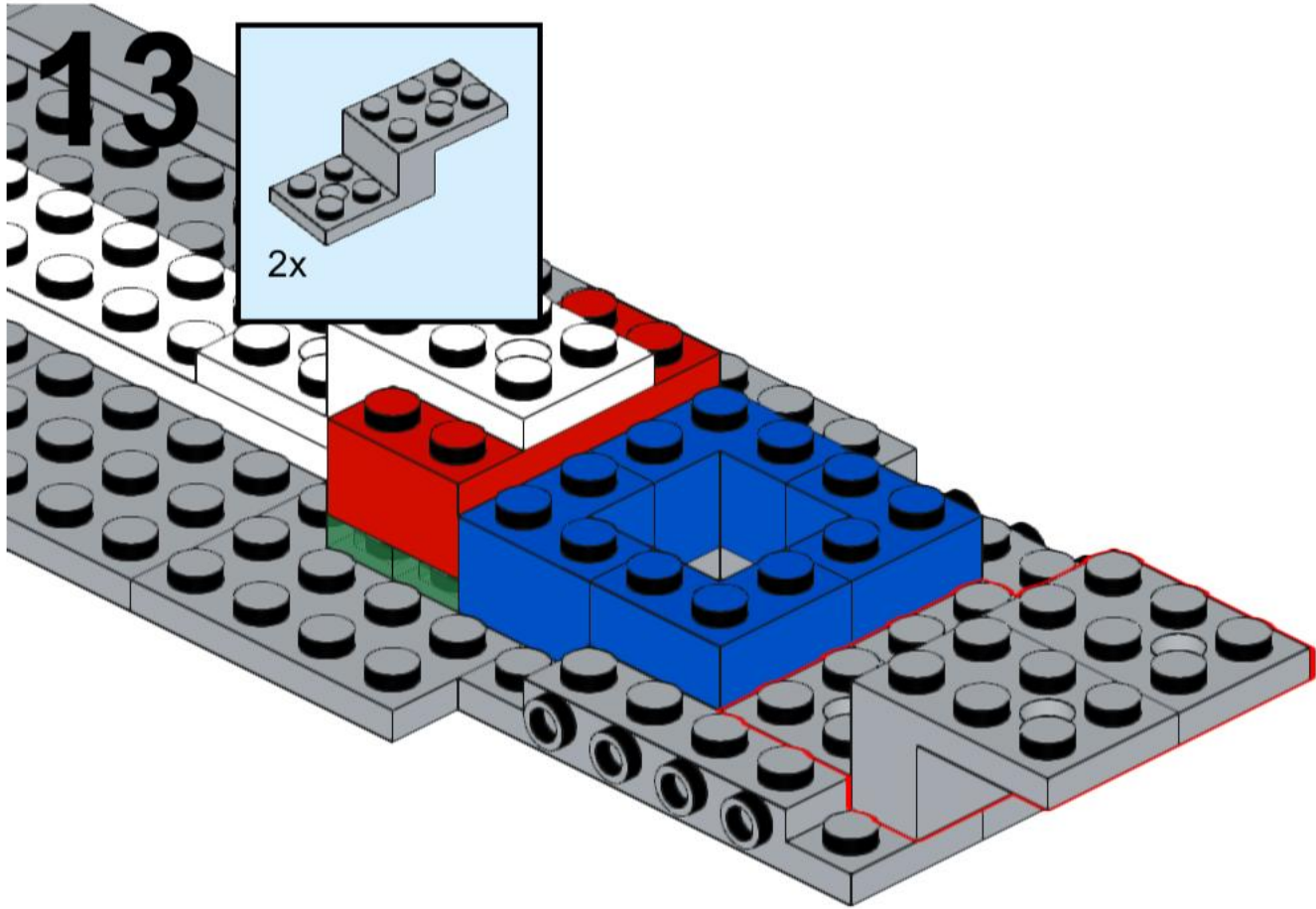

13

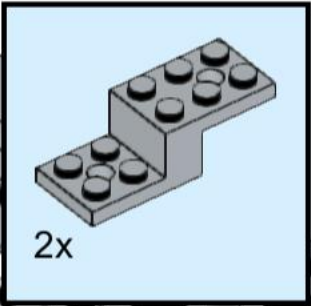

2x

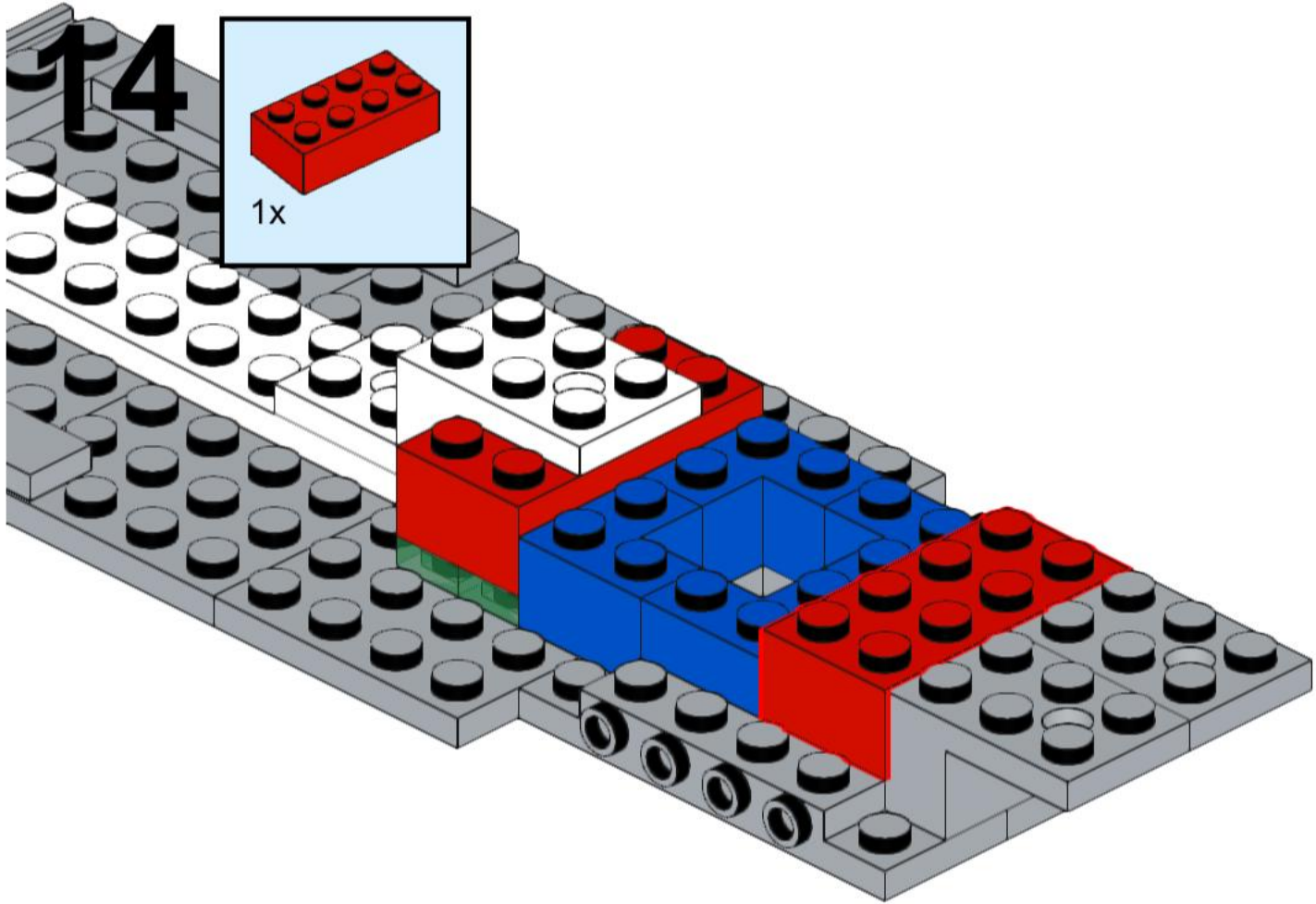

16

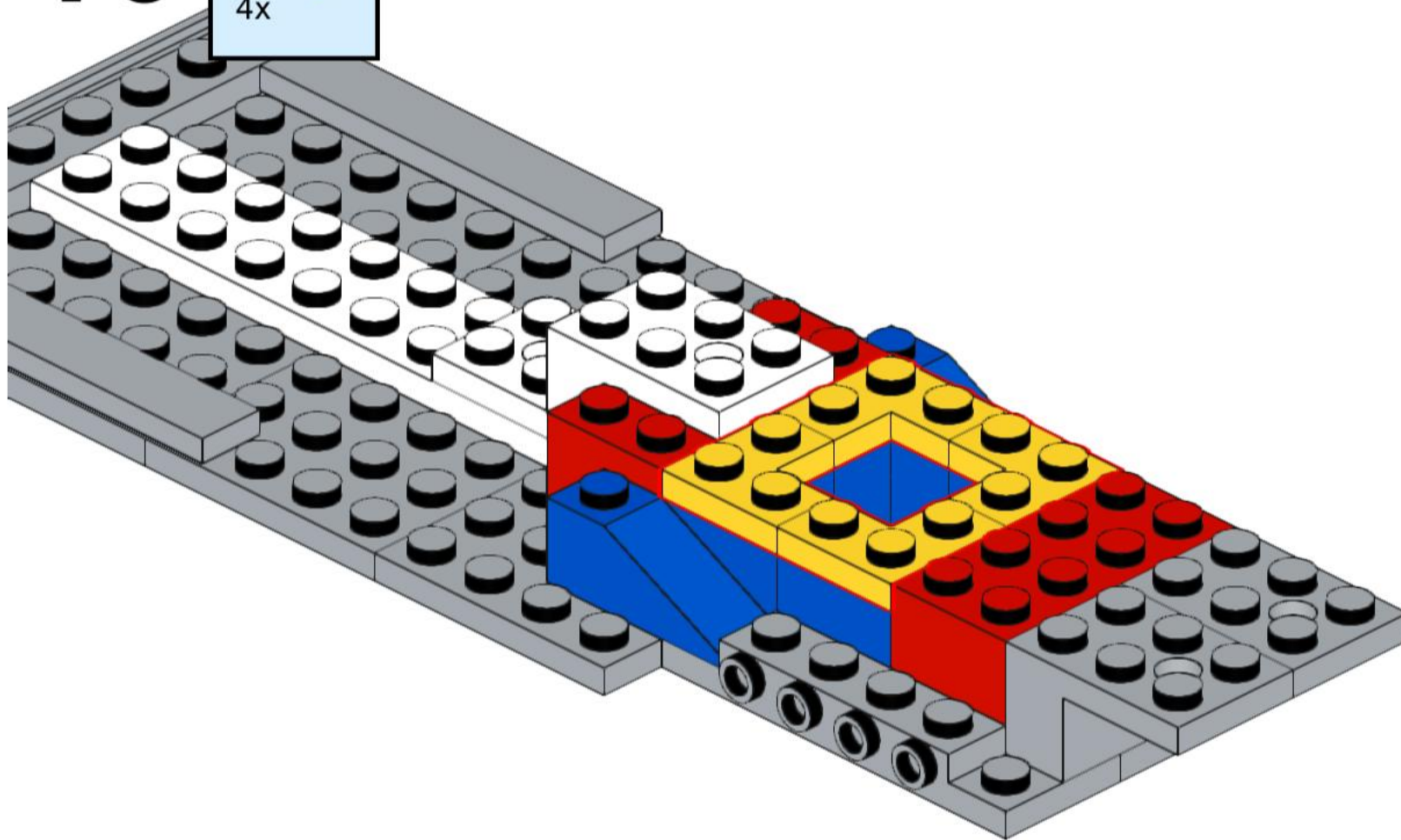
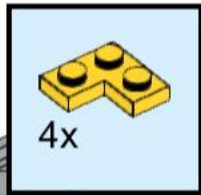

17

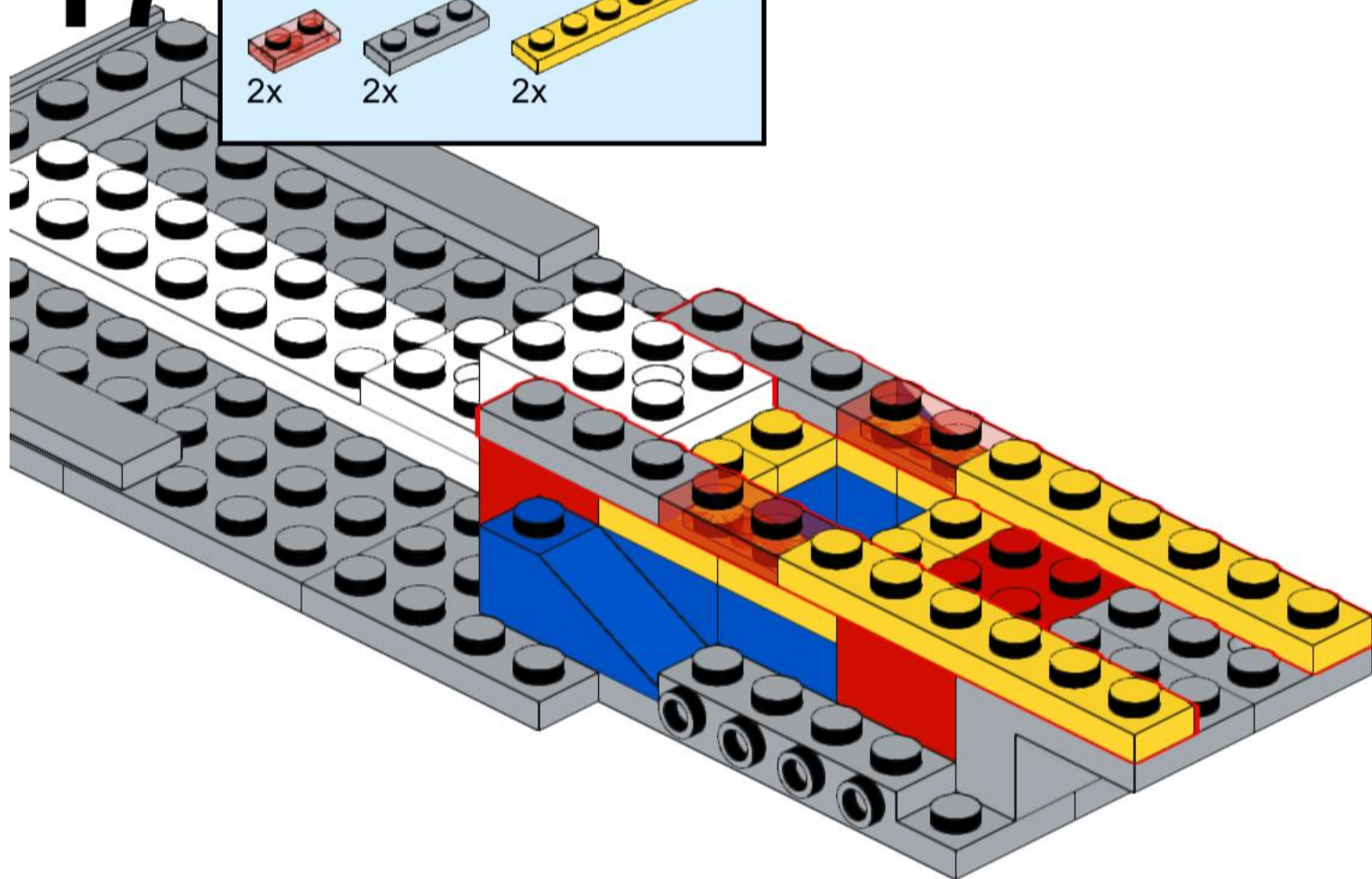
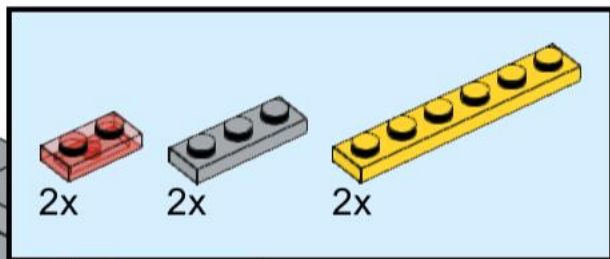

18

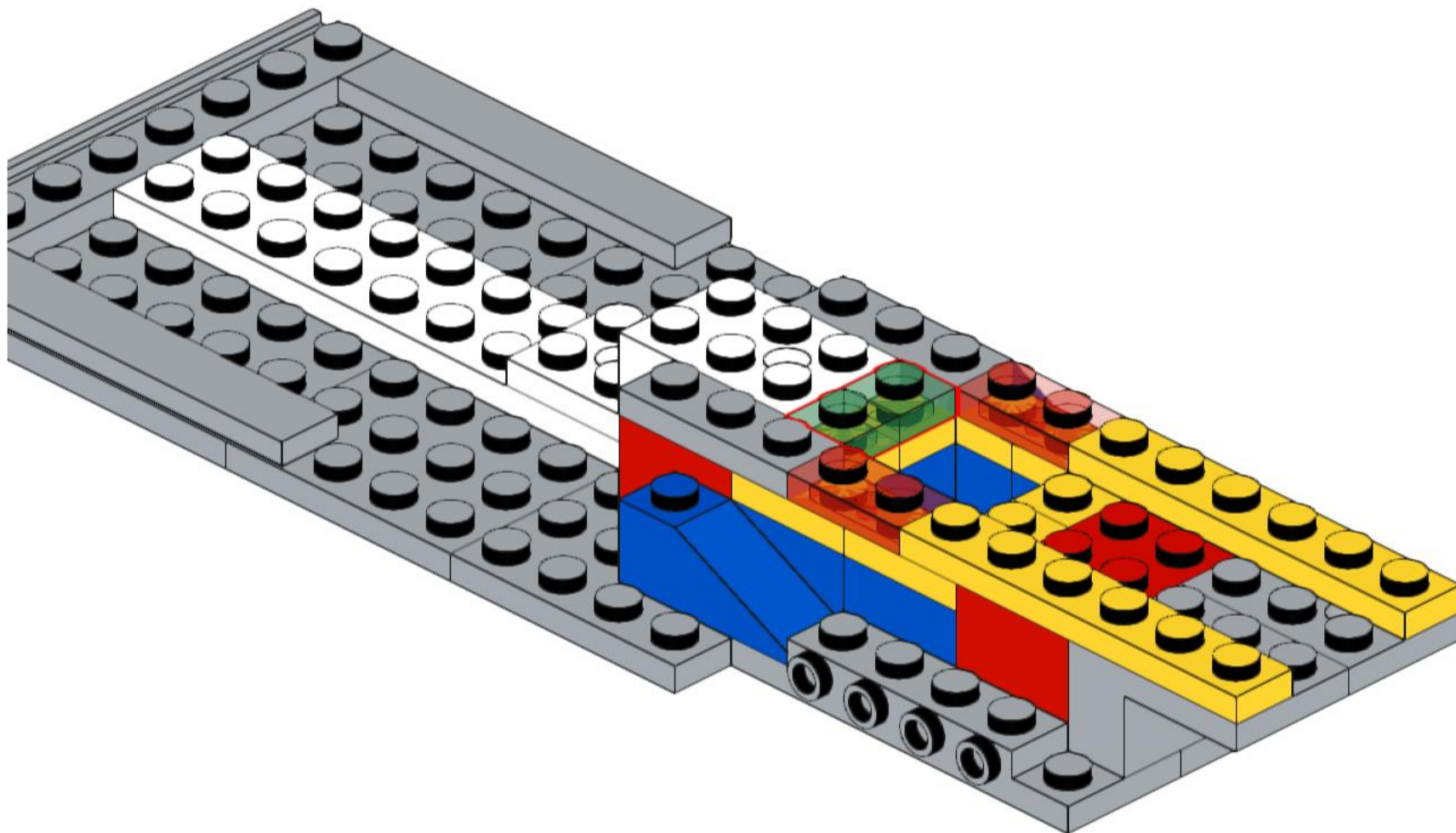
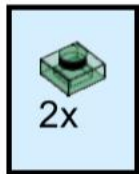

19

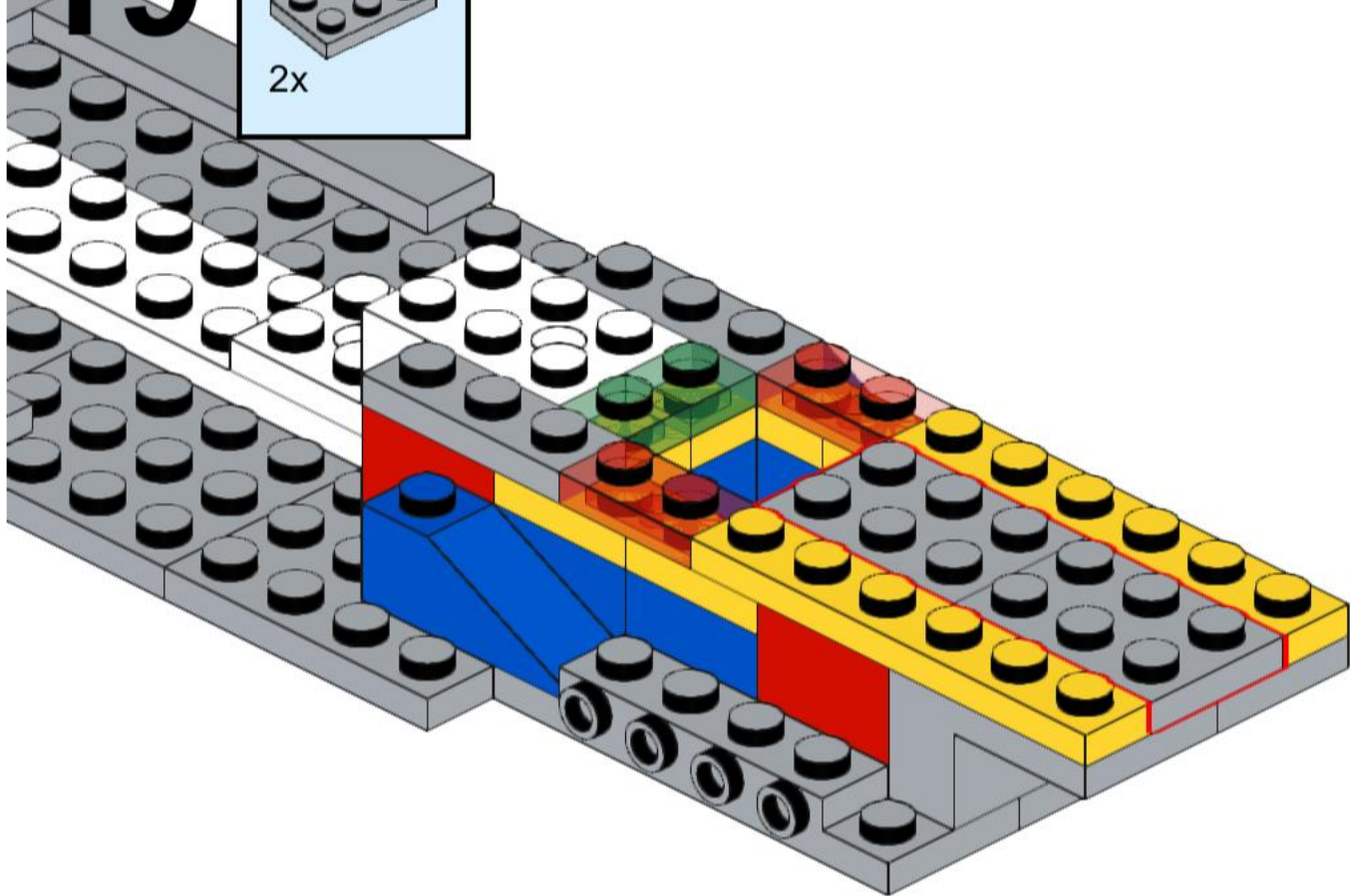
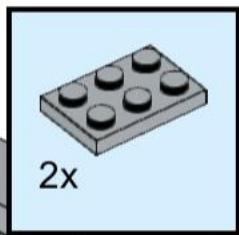

22

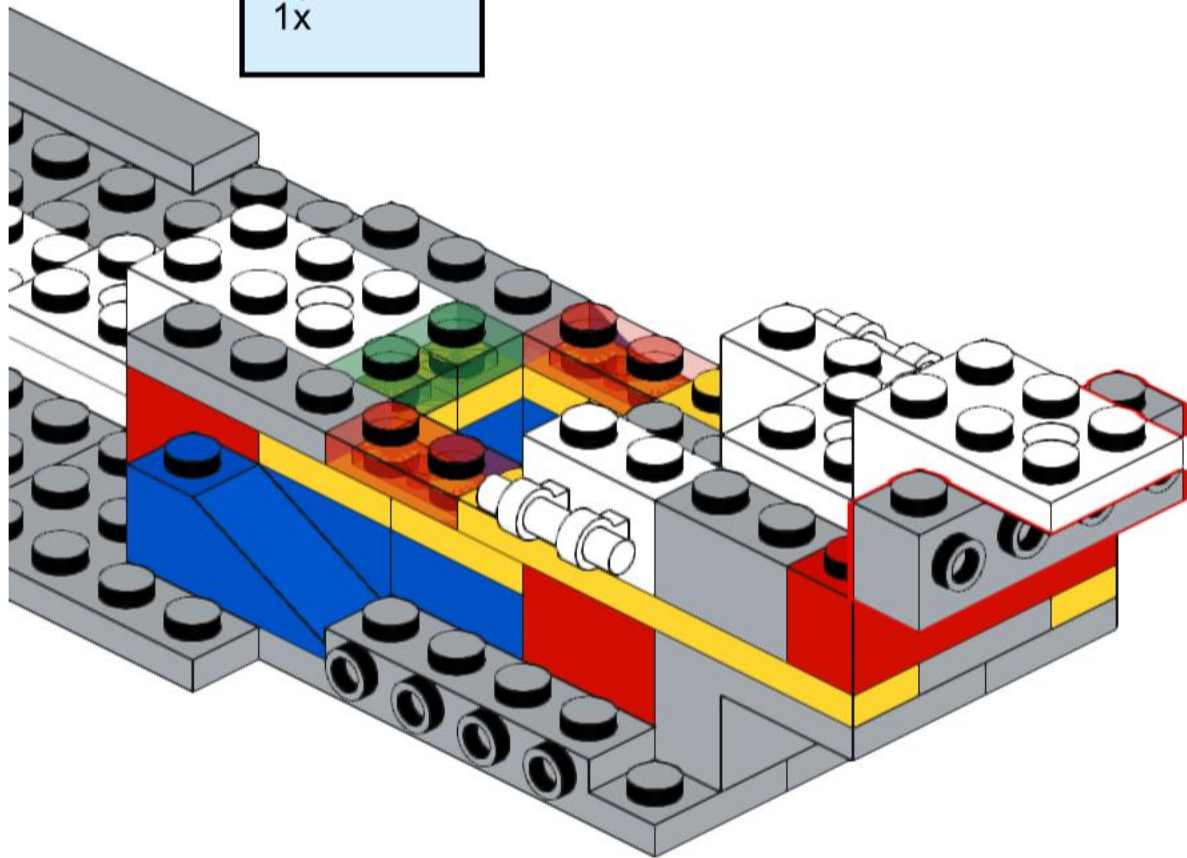
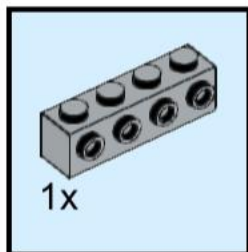

24

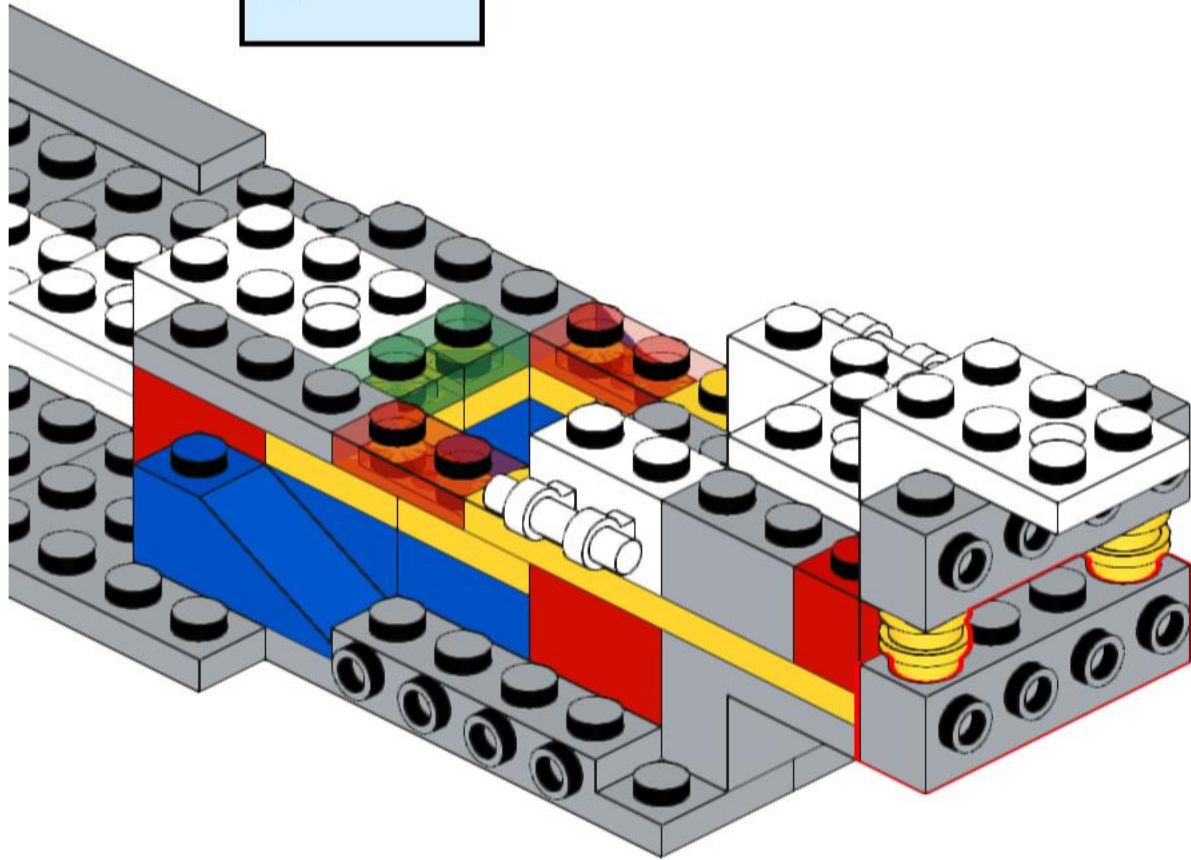
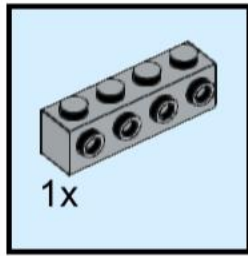

25

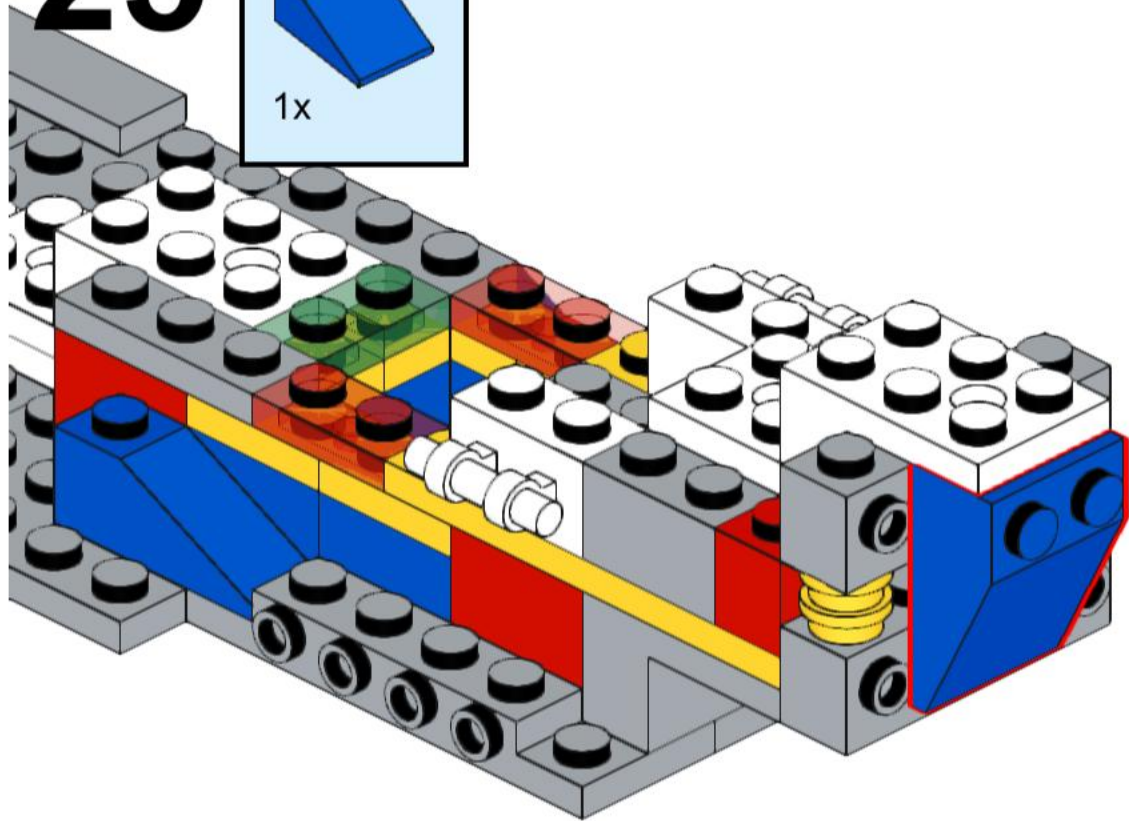
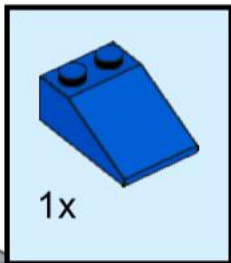

26

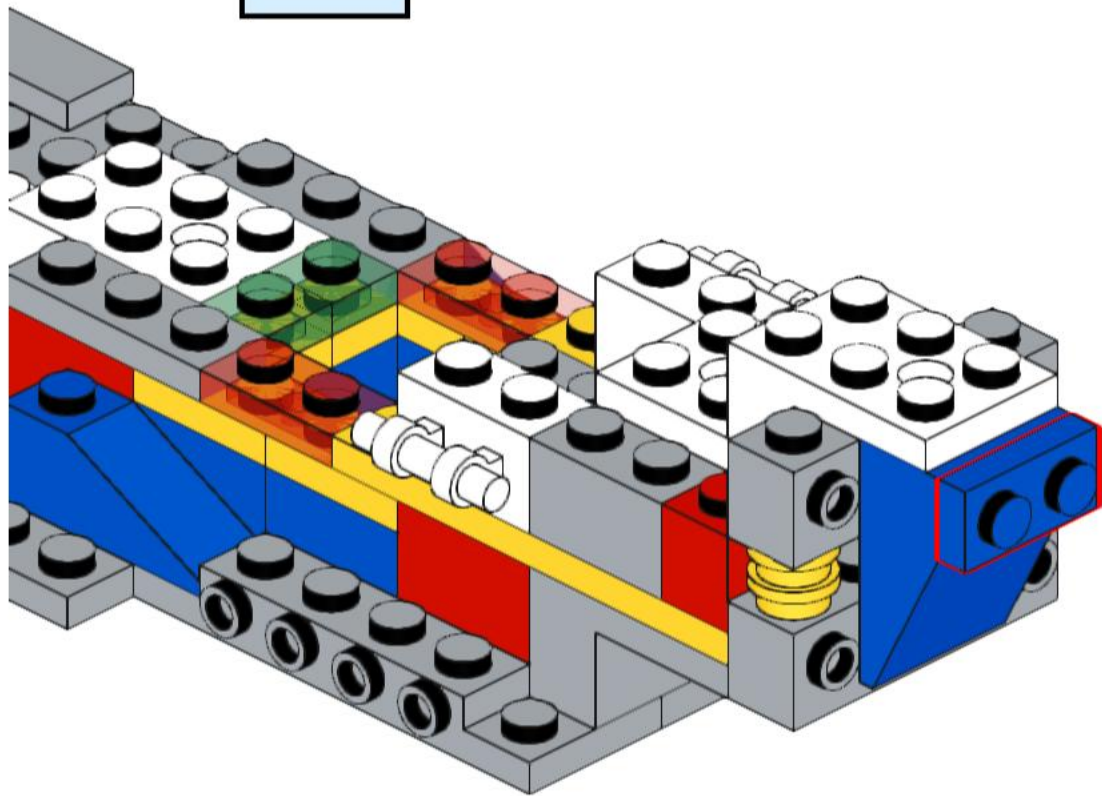
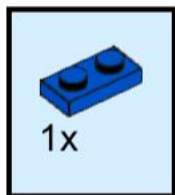

28

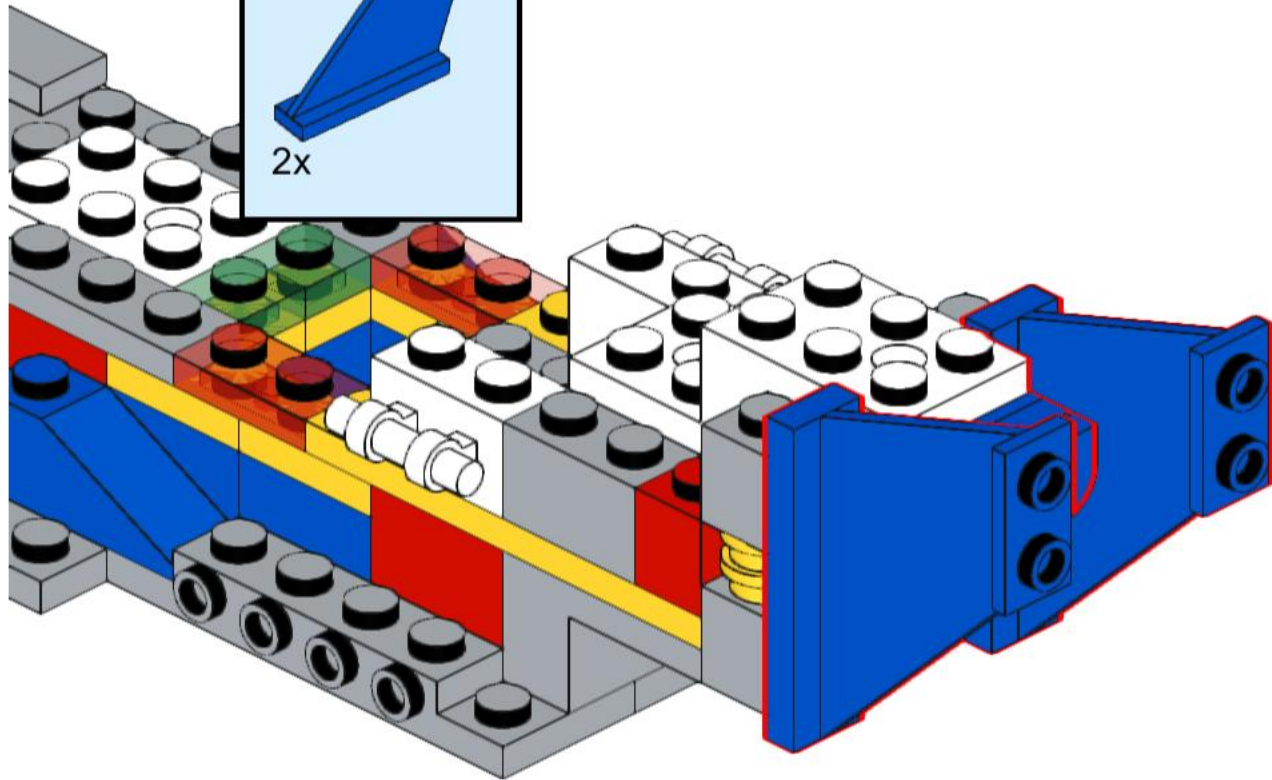
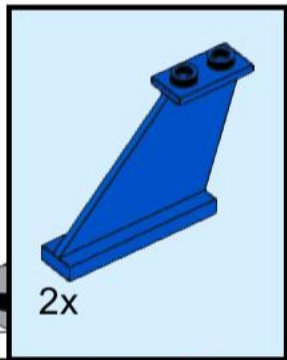

Attach here



29

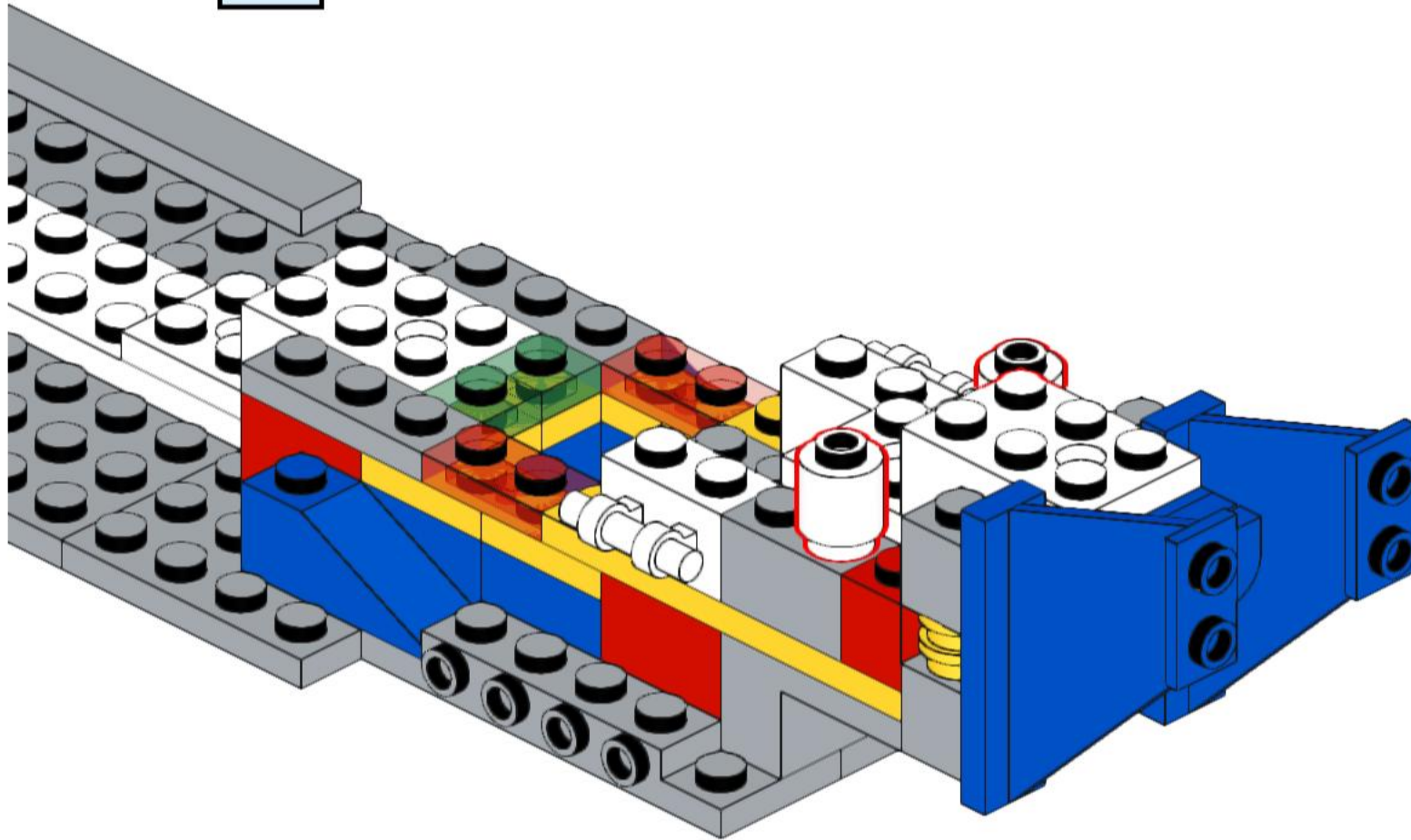

30

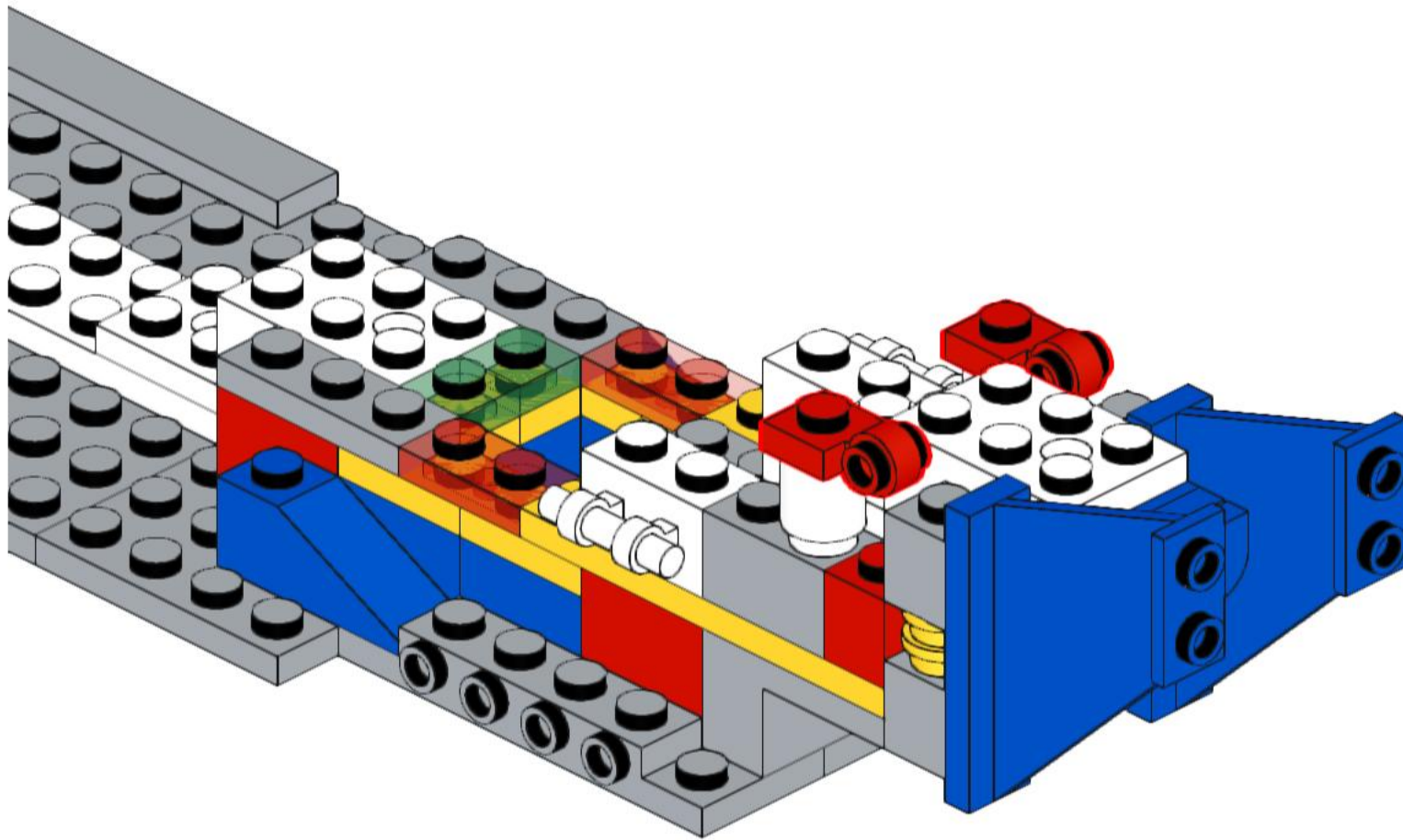

32

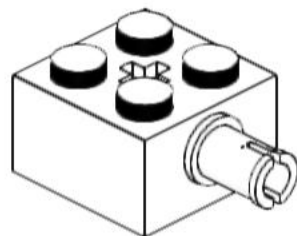
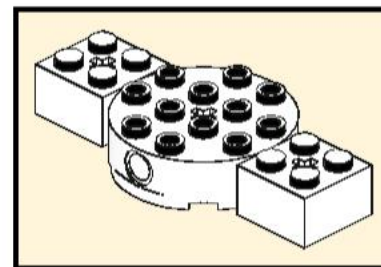
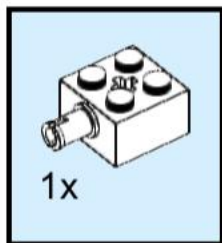

33

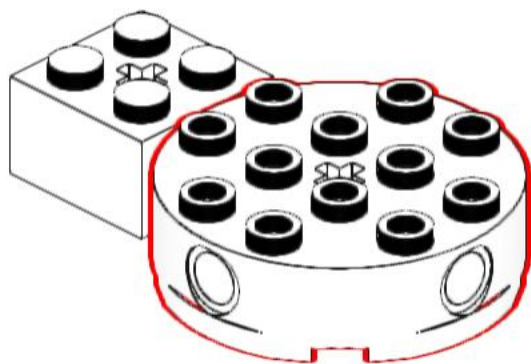
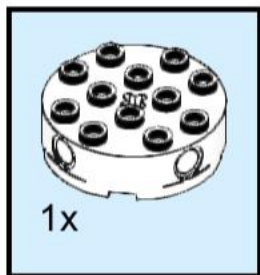

34

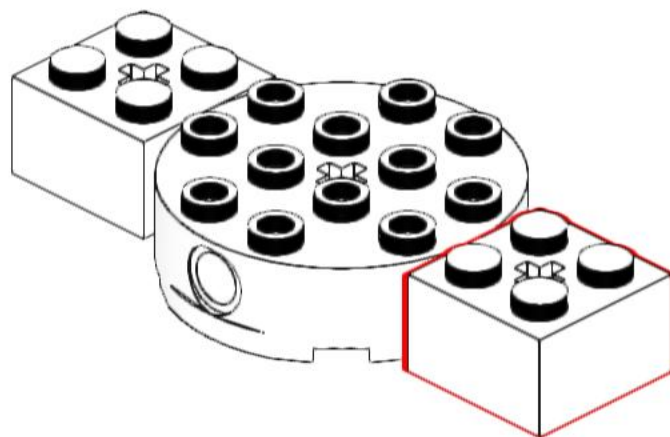
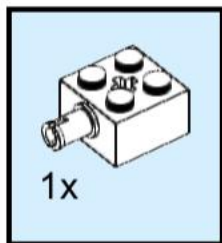

36

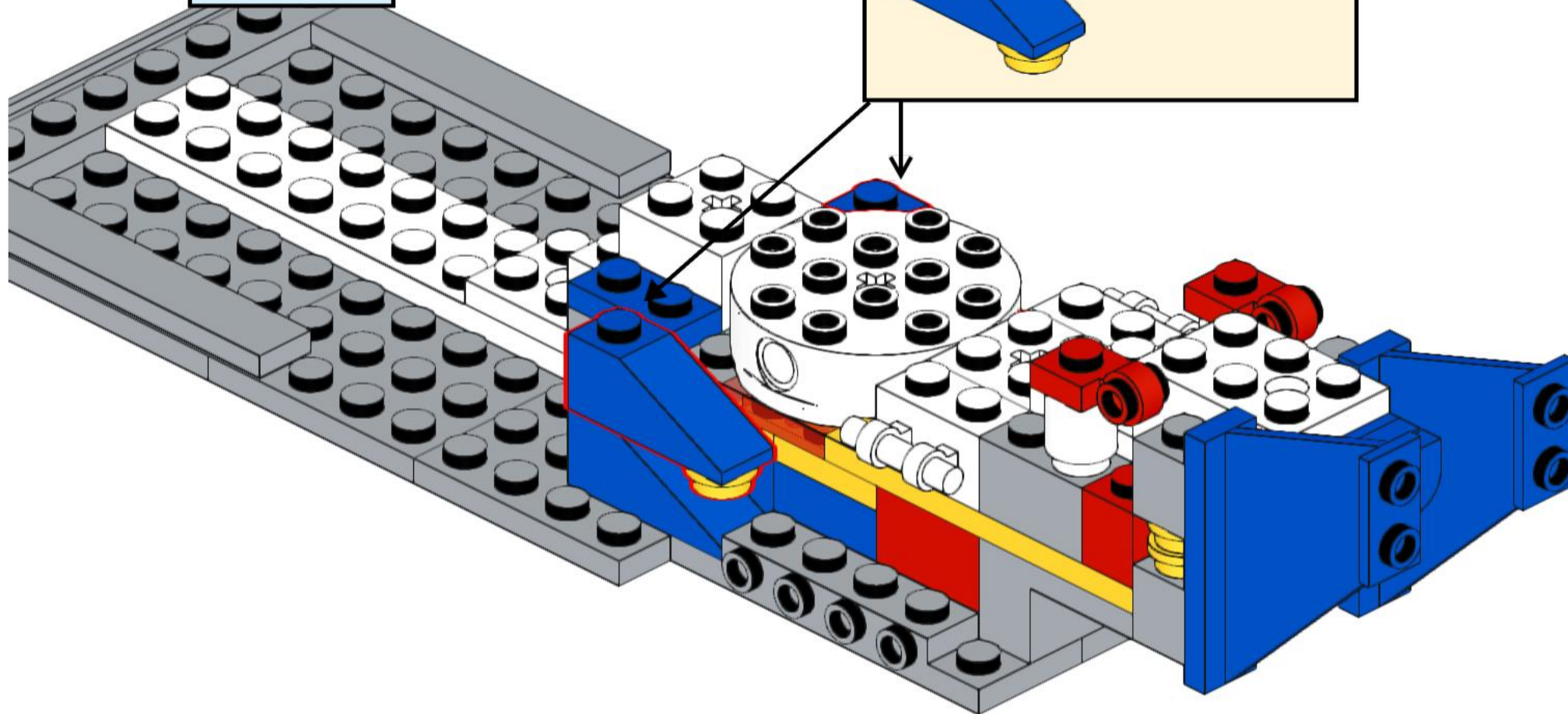
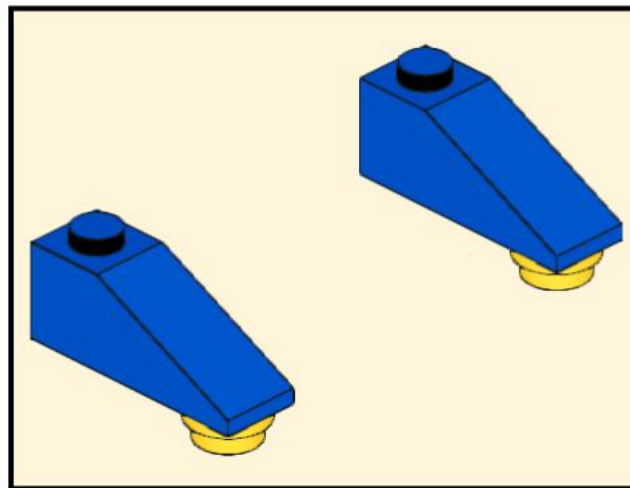

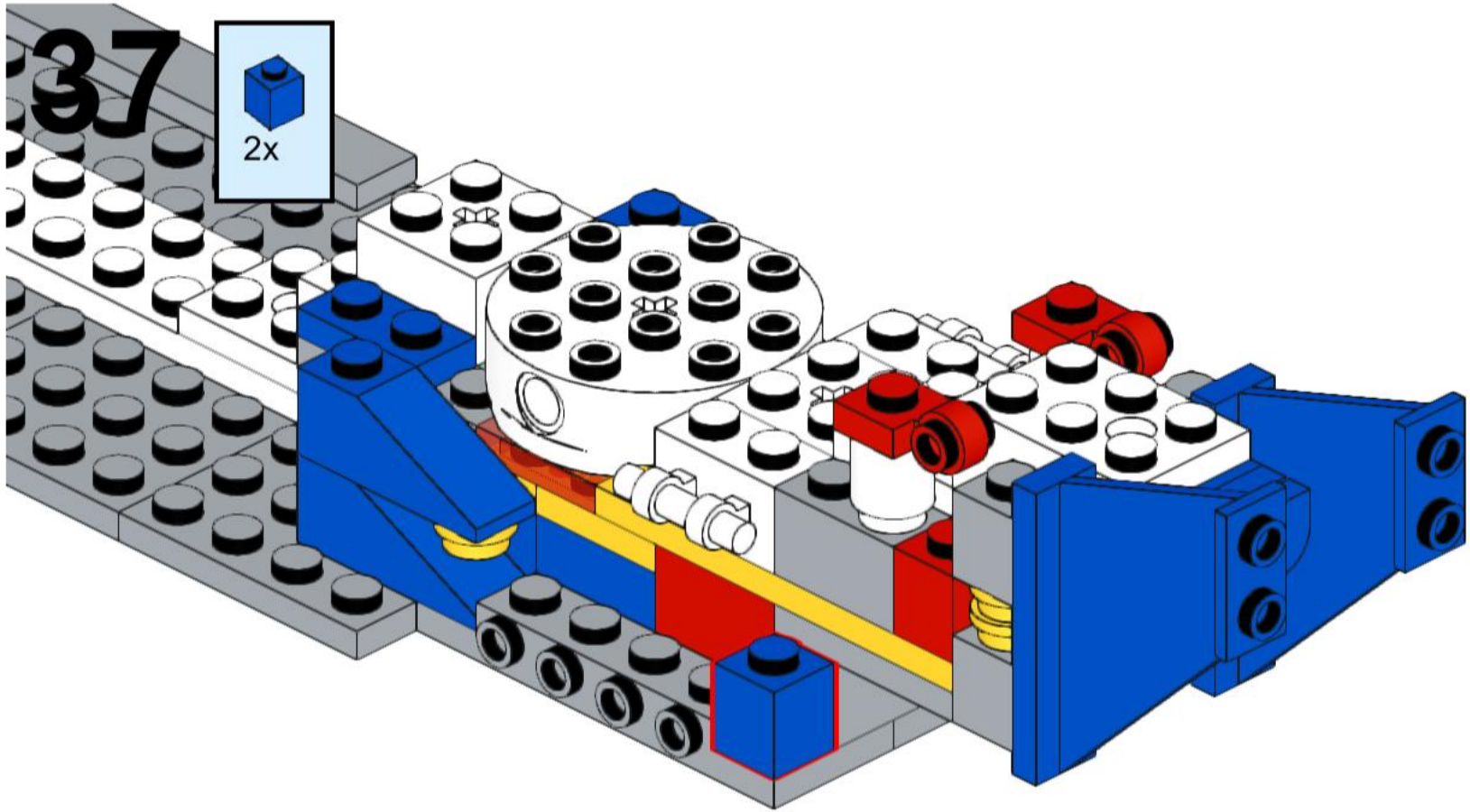

38

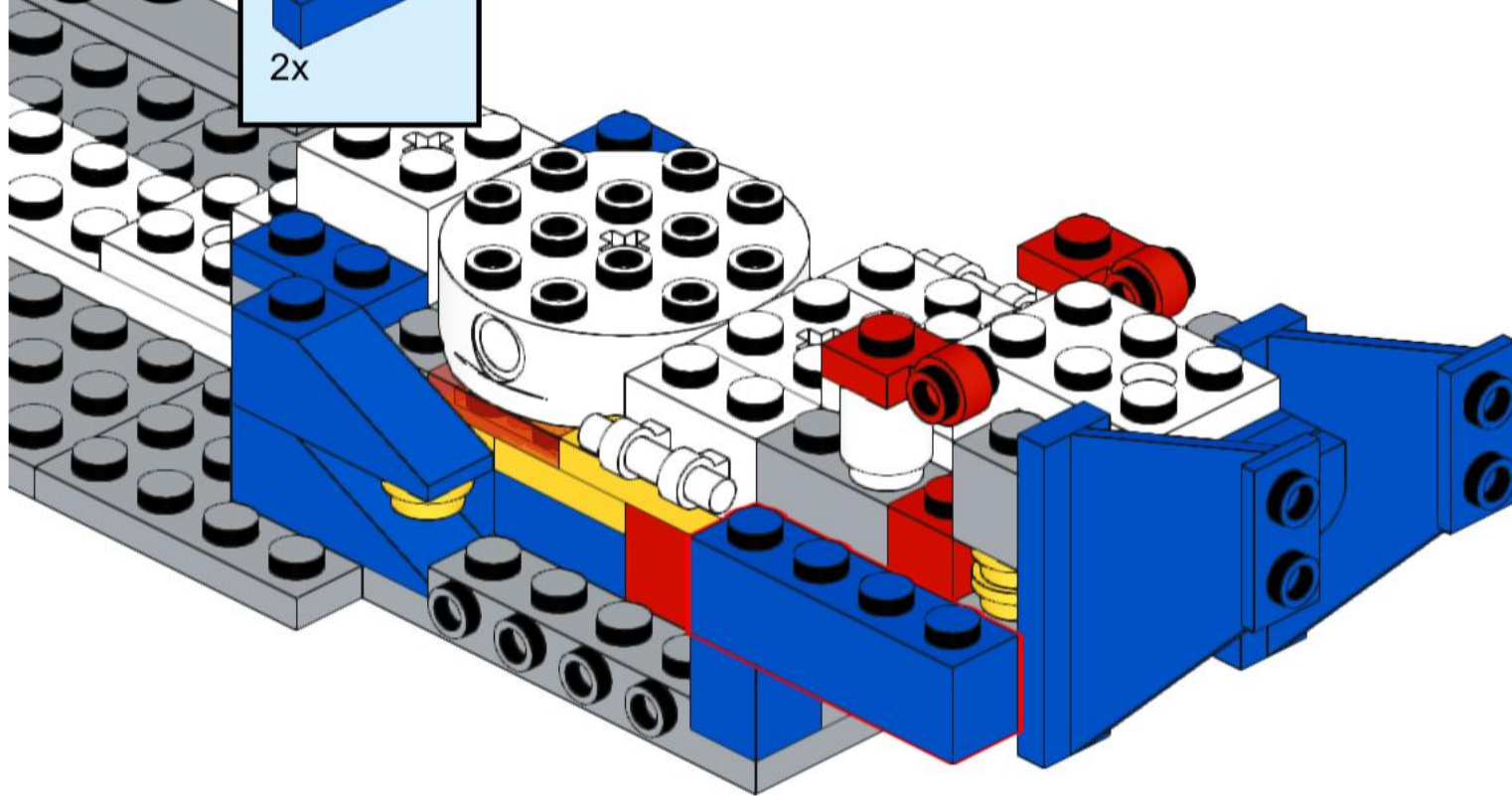
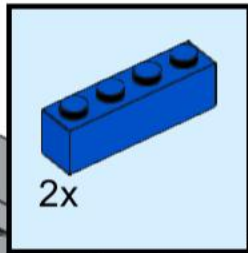

40

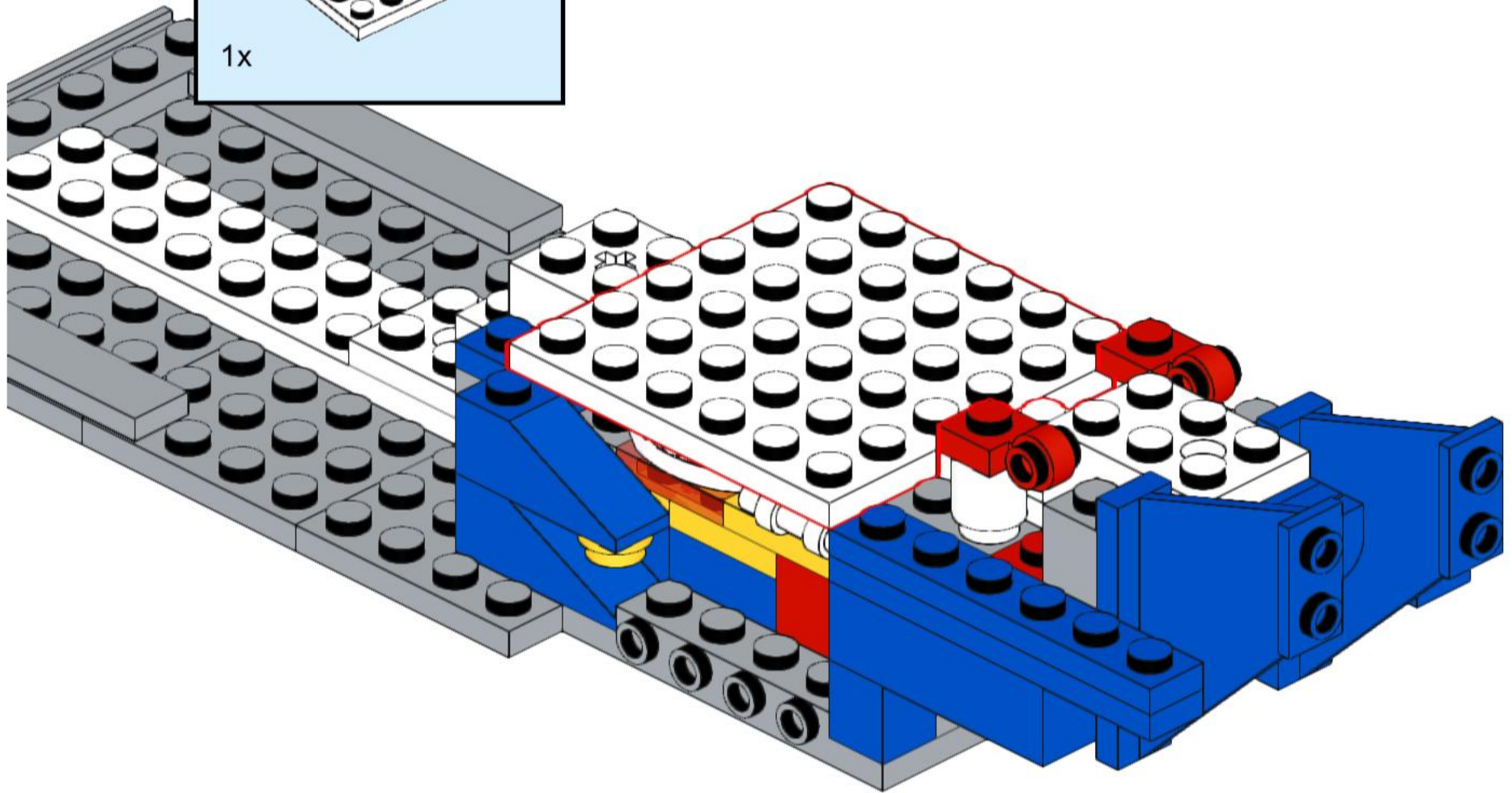
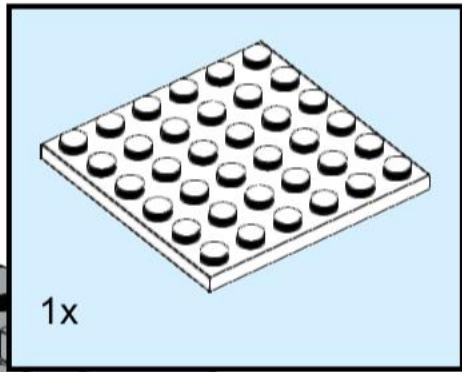

41

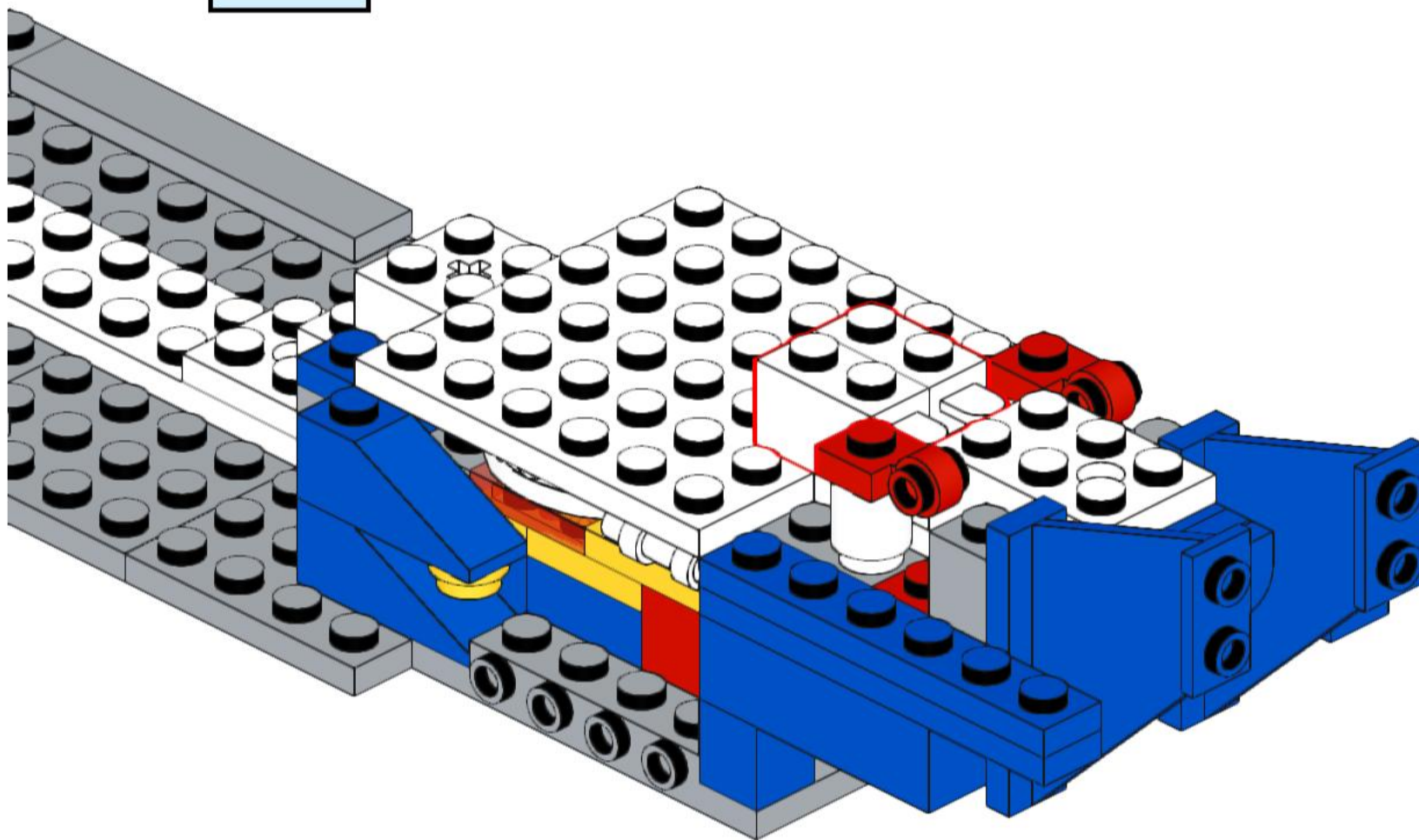
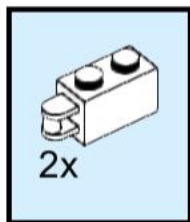

42

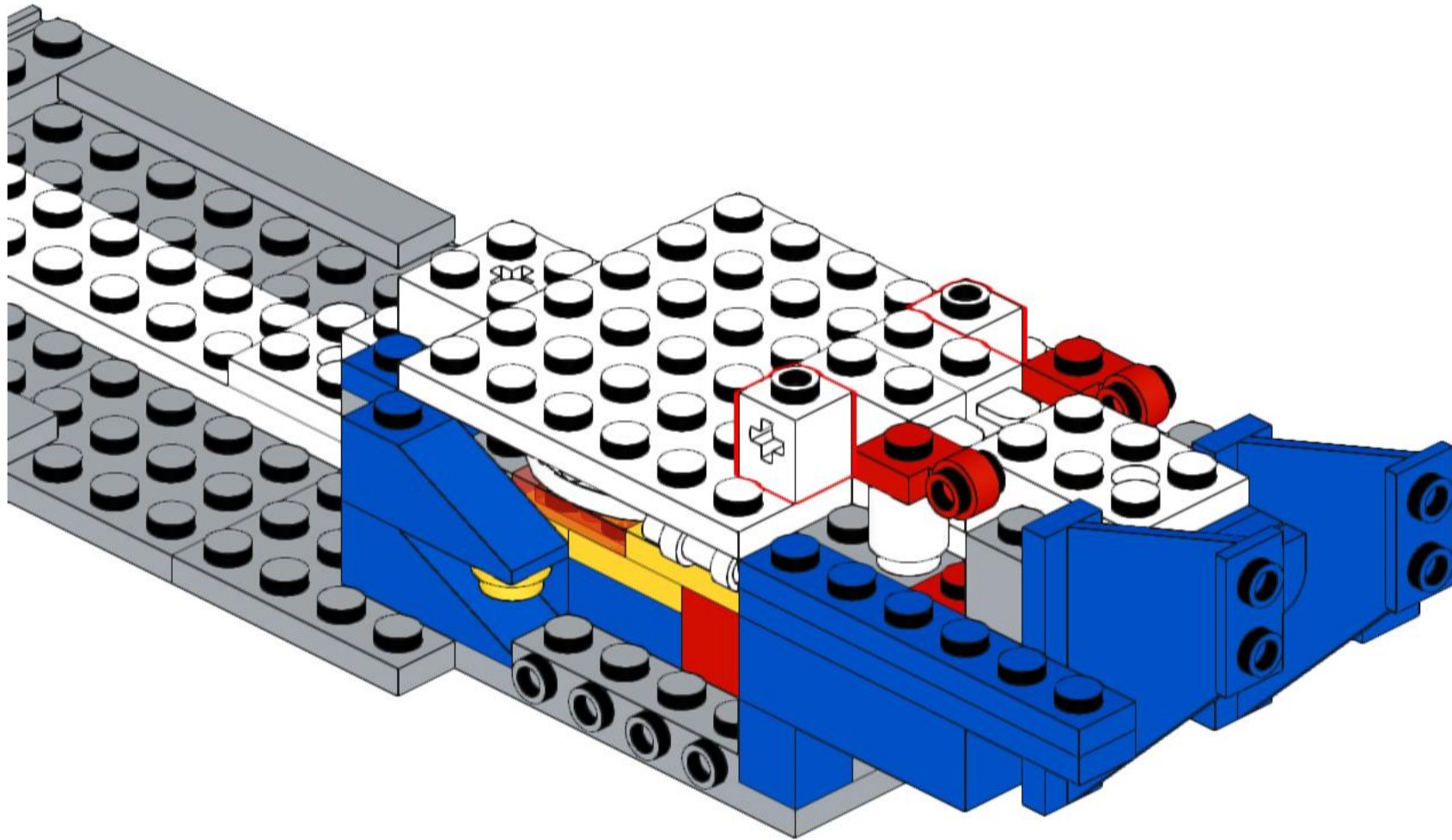
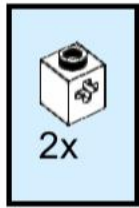

43

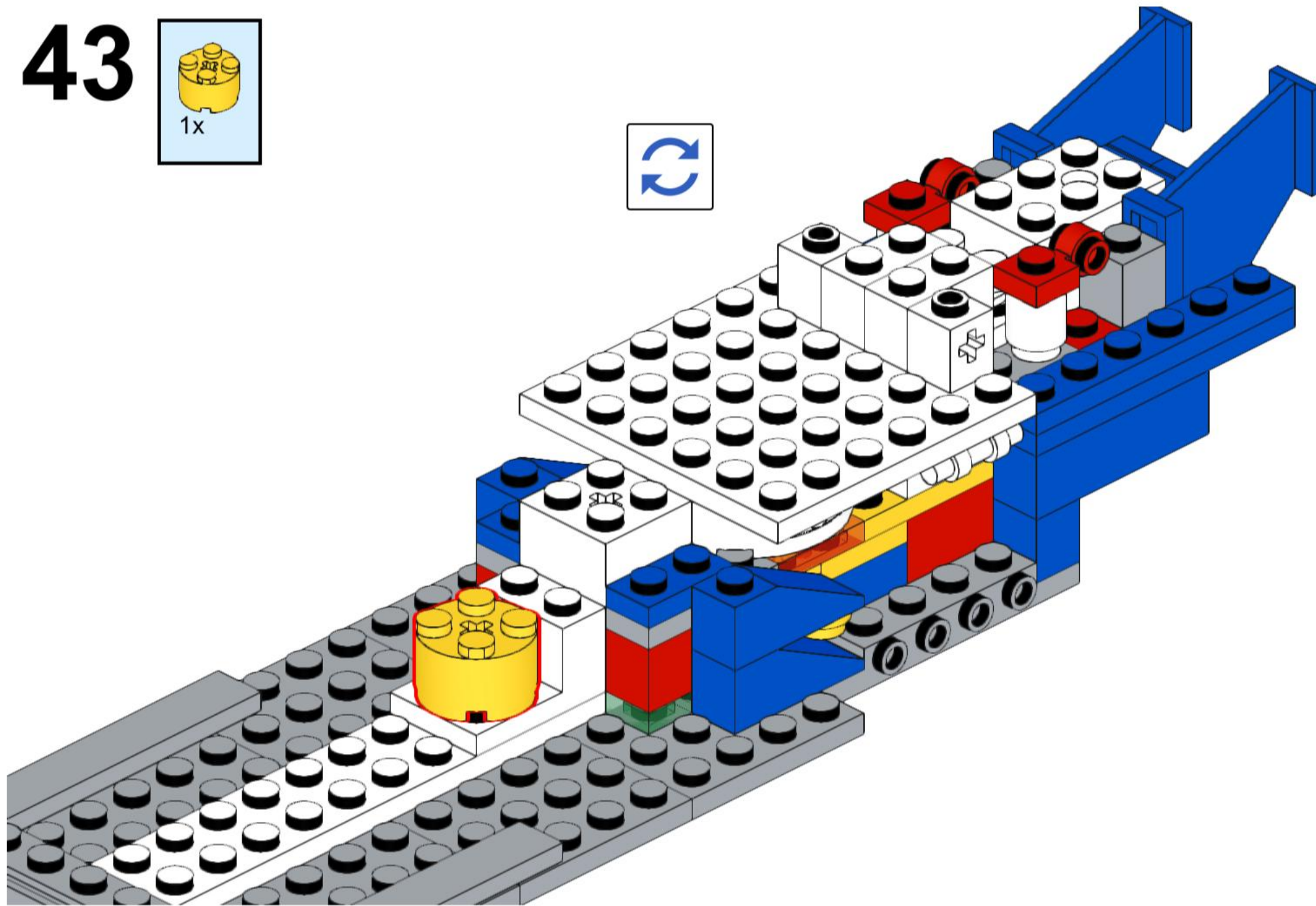
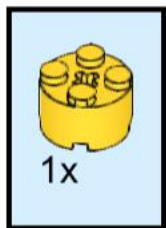

44

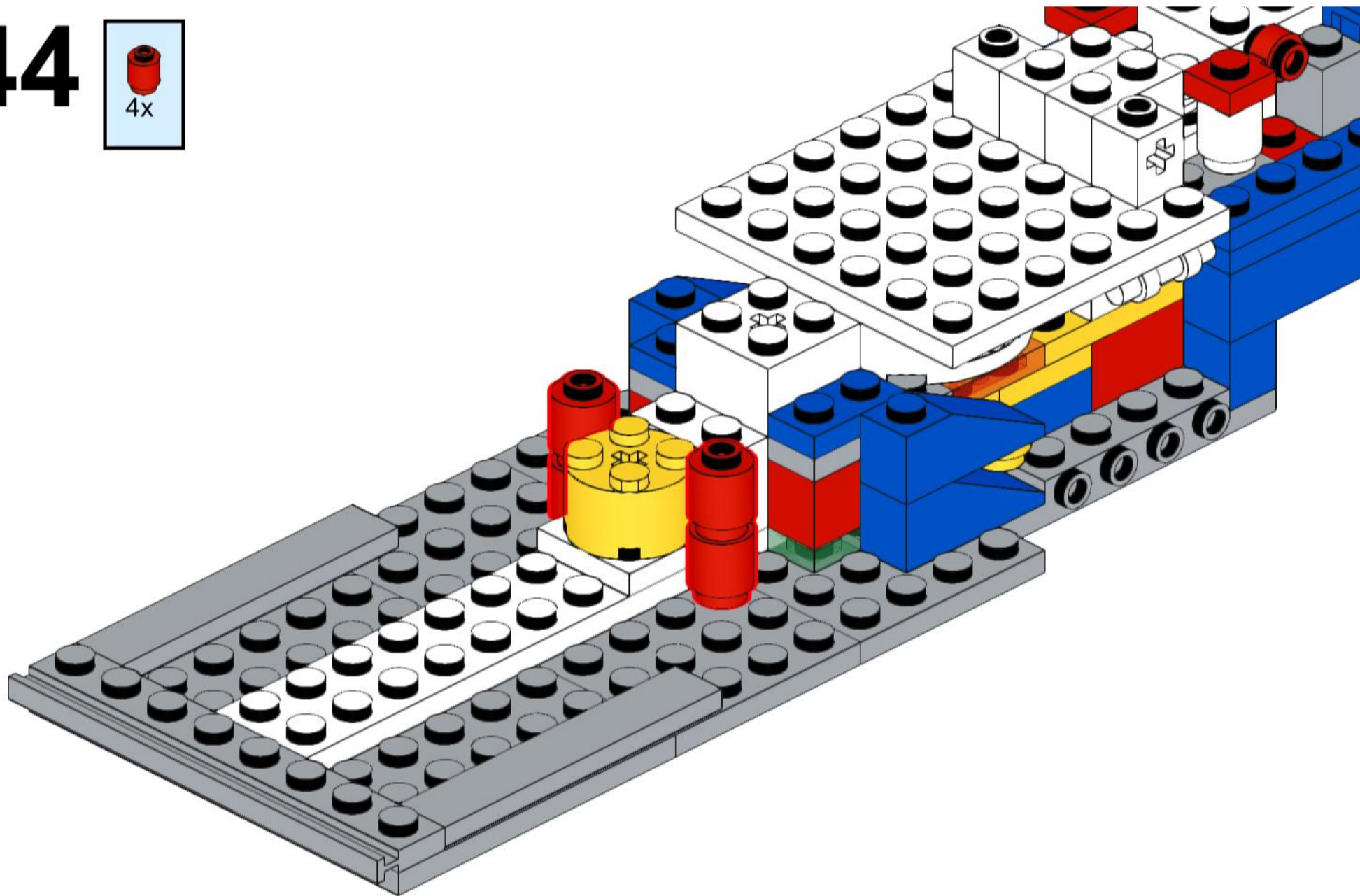
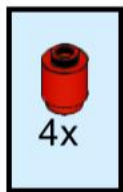

45

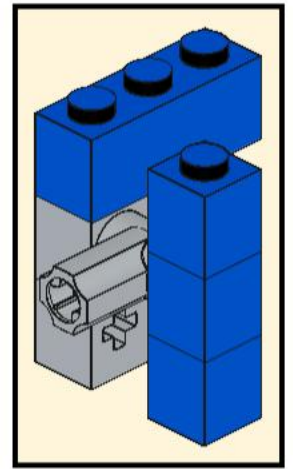
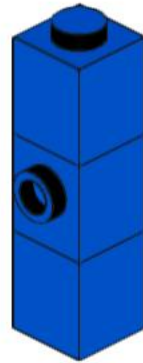
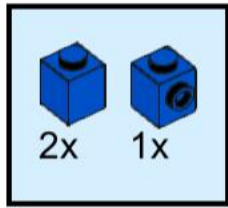

46

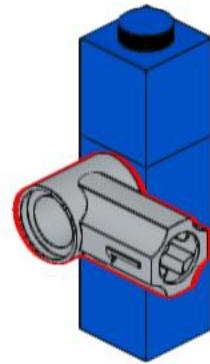
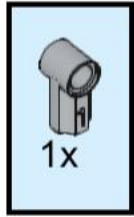

47

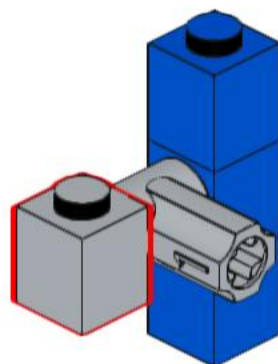
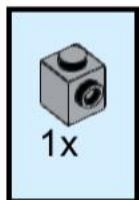

48

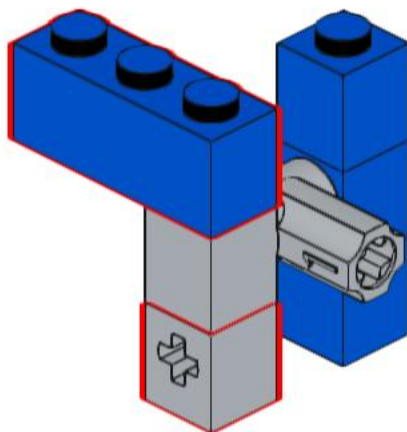
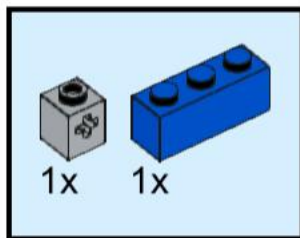

49

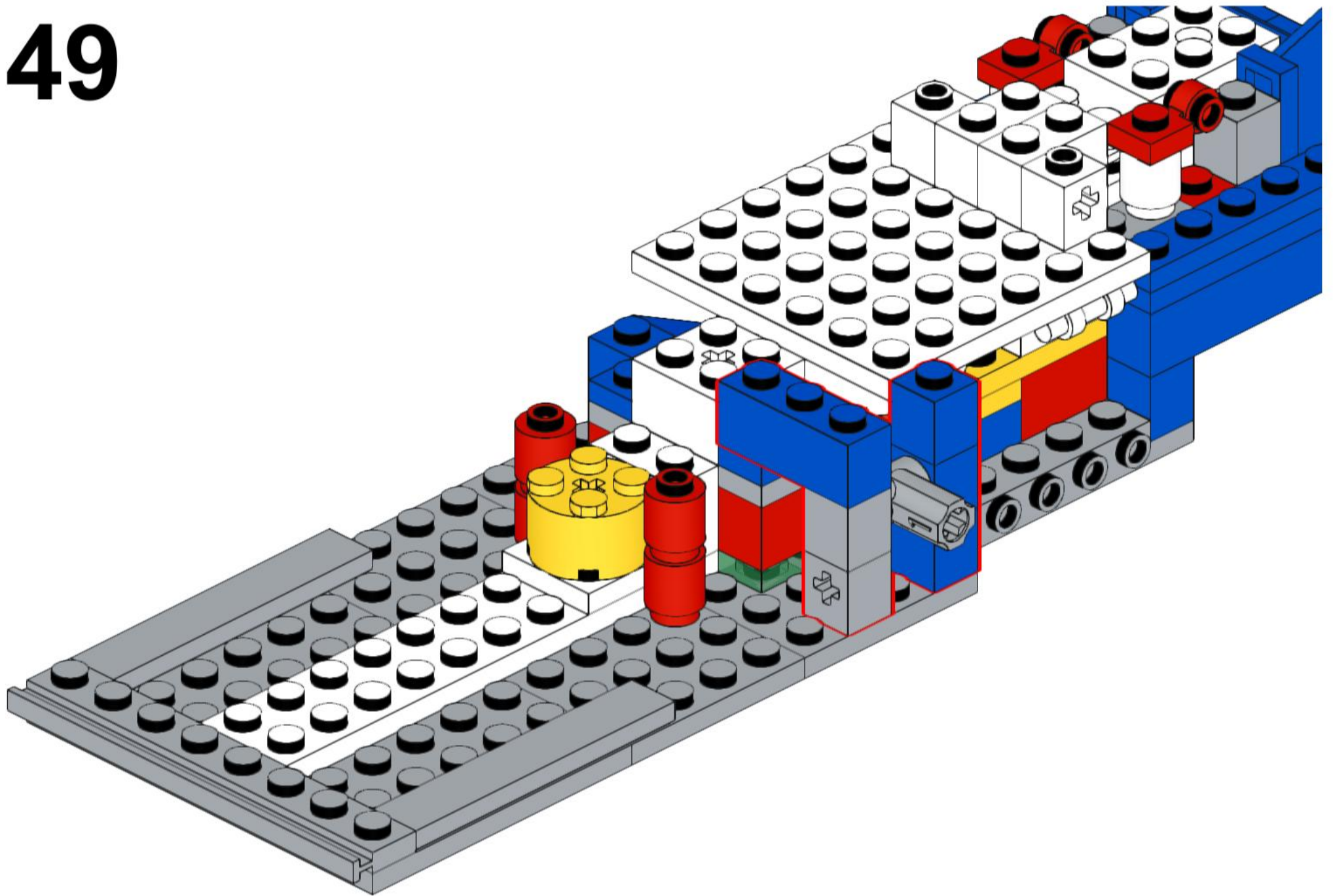

50

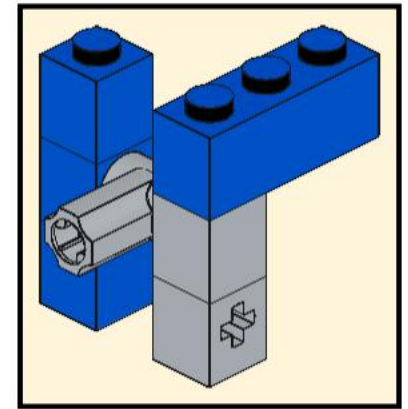
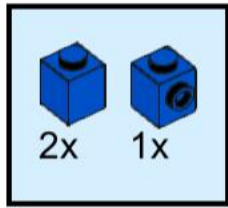

51

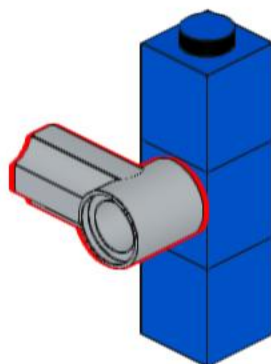
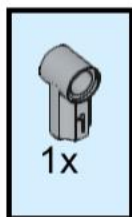

52

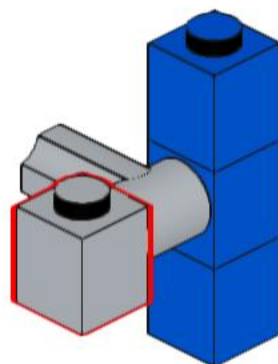
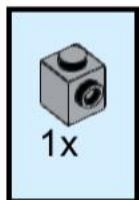

53

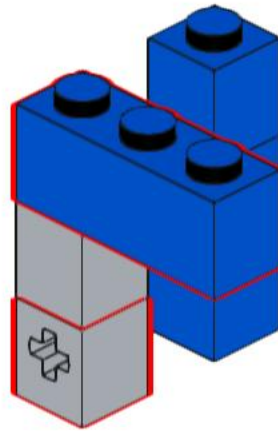
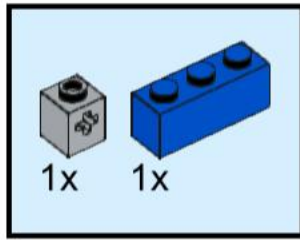

54

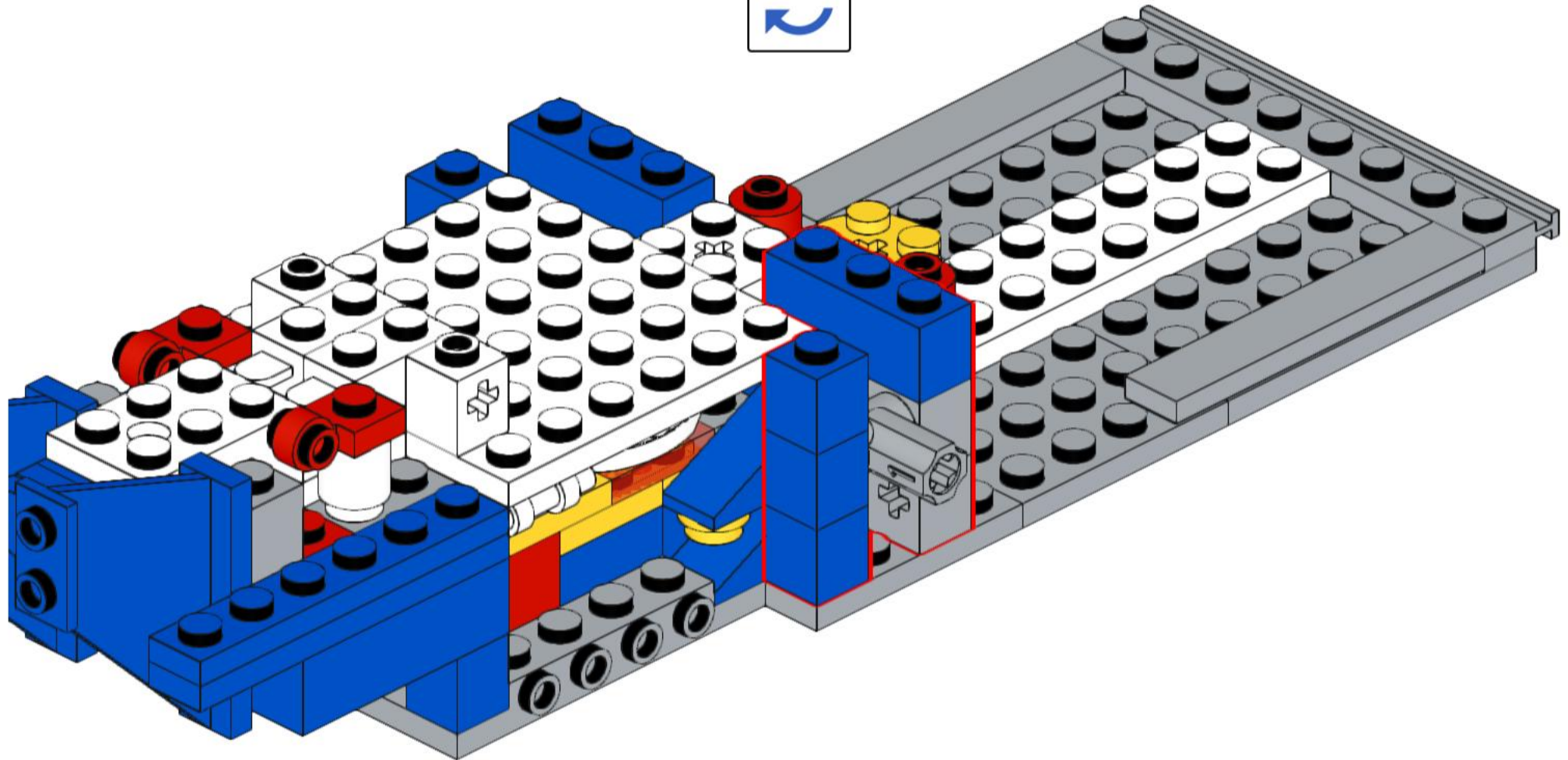

55

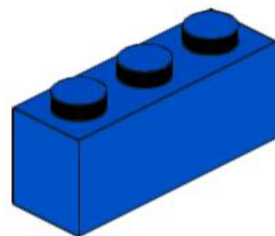
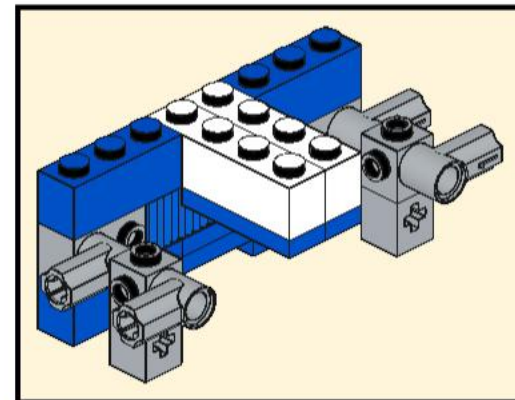
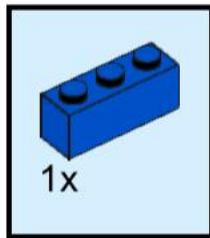

56

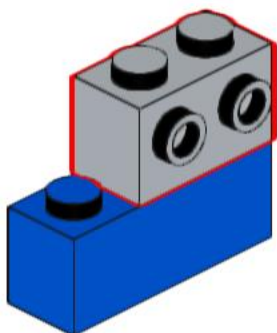
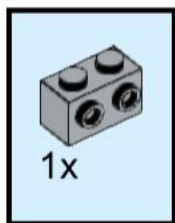

57

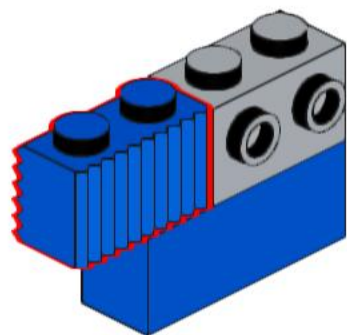
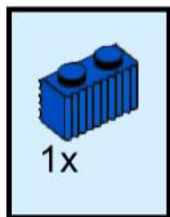

58

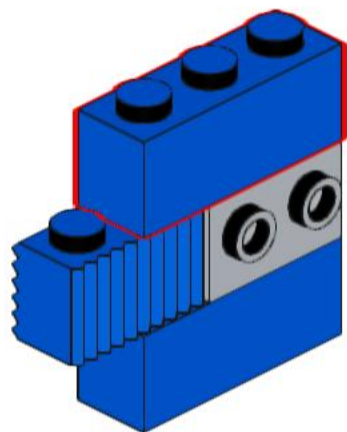
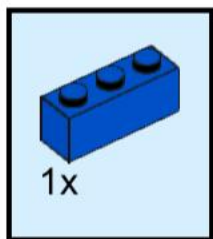

59

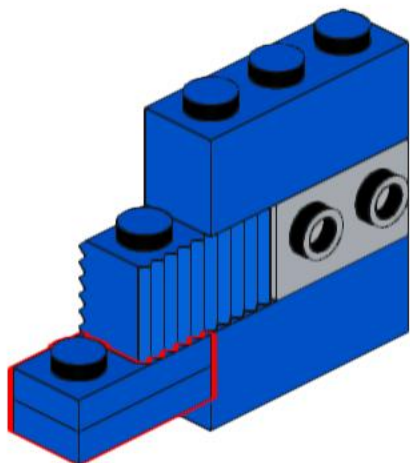
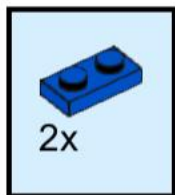

60

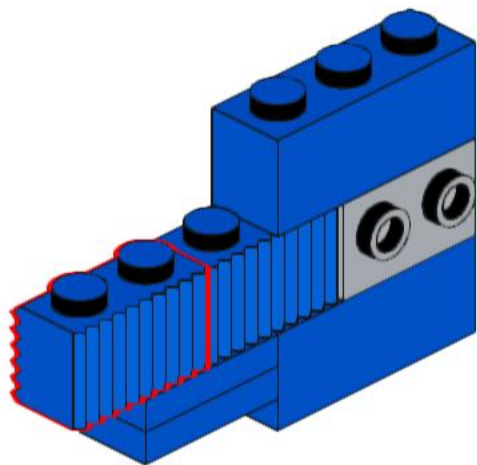
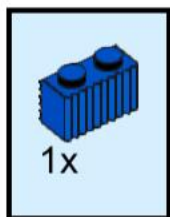

61

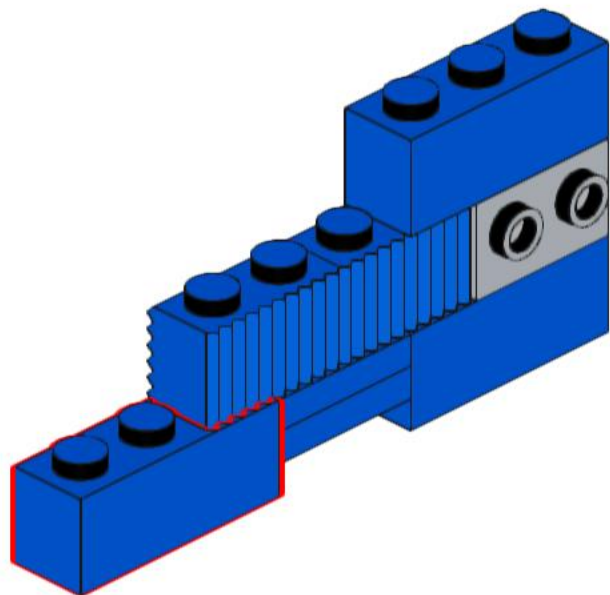
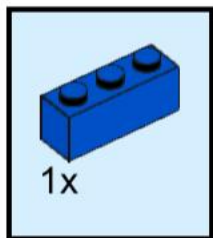

62

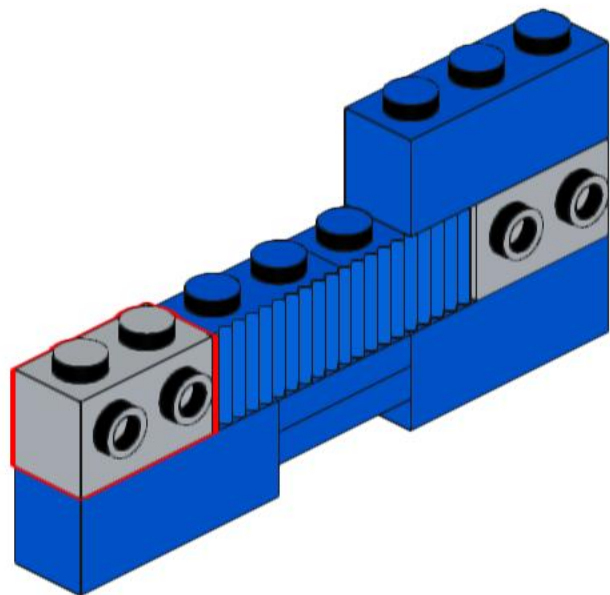
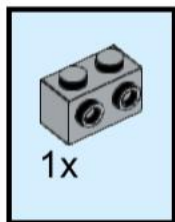

63

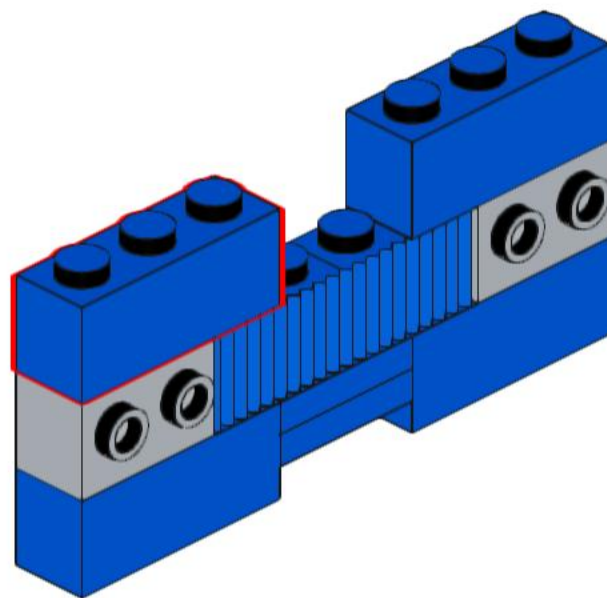
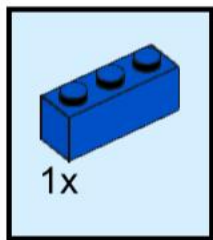

64

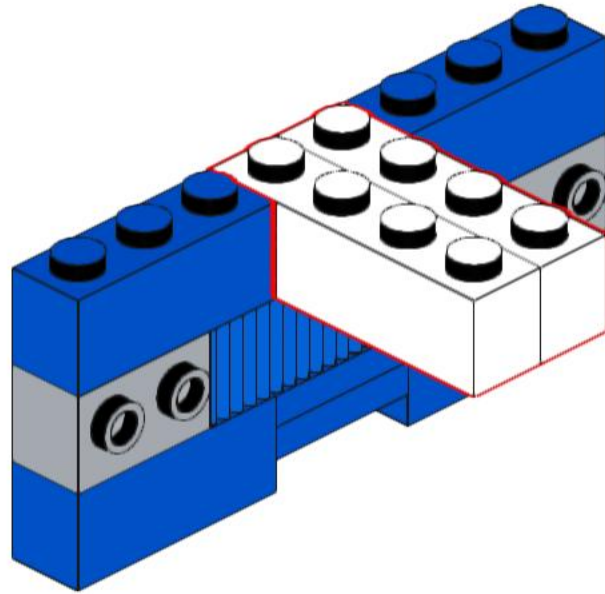
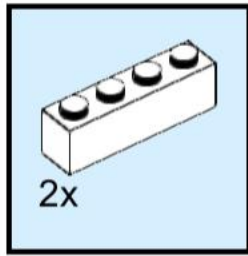

65

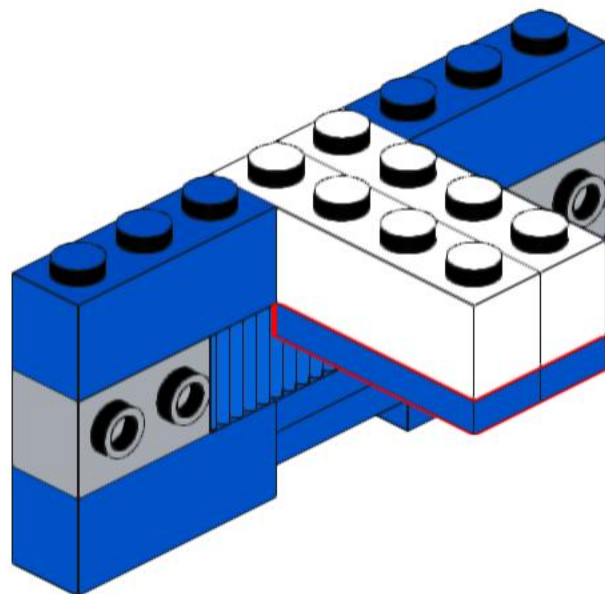
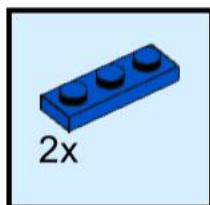

66

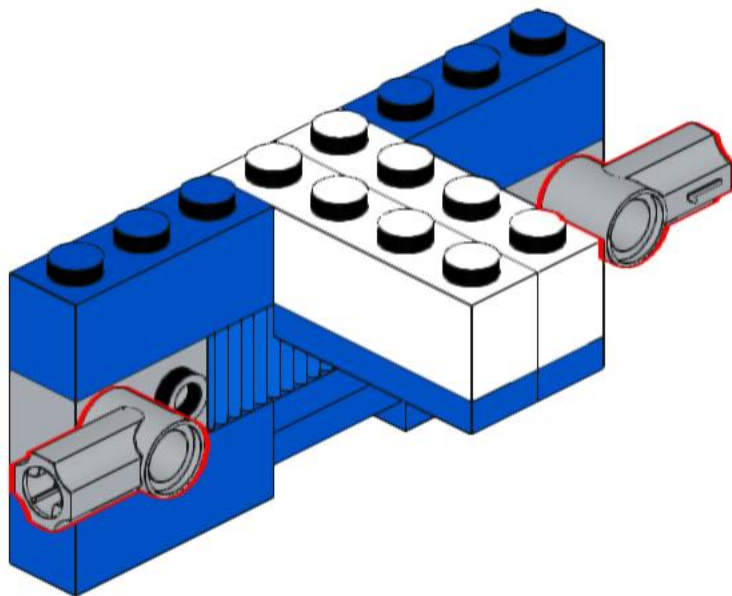
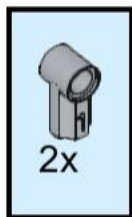

67

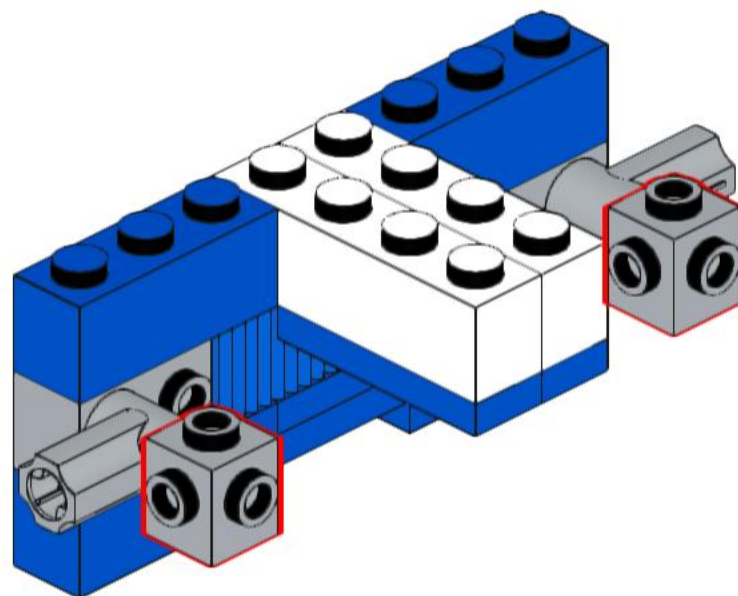
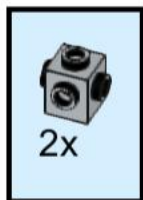

68

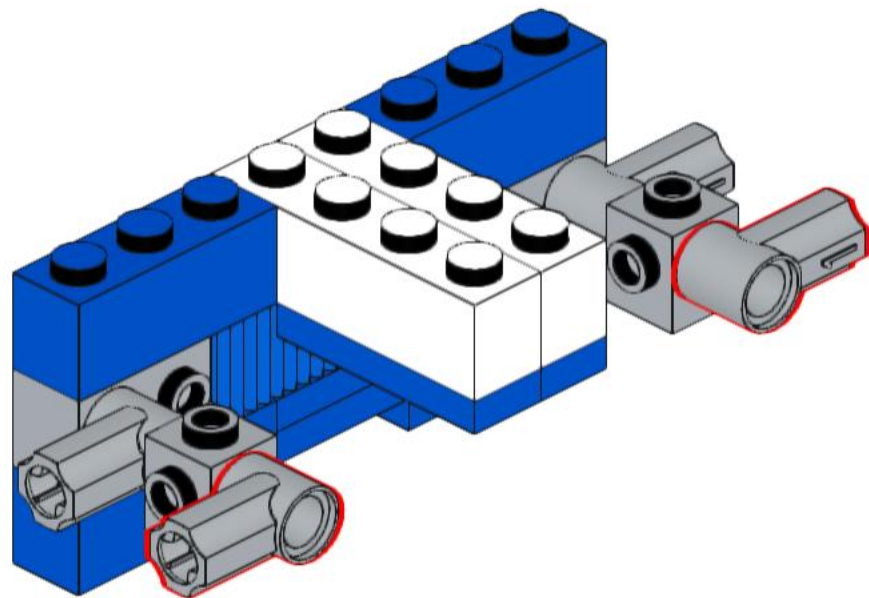

69

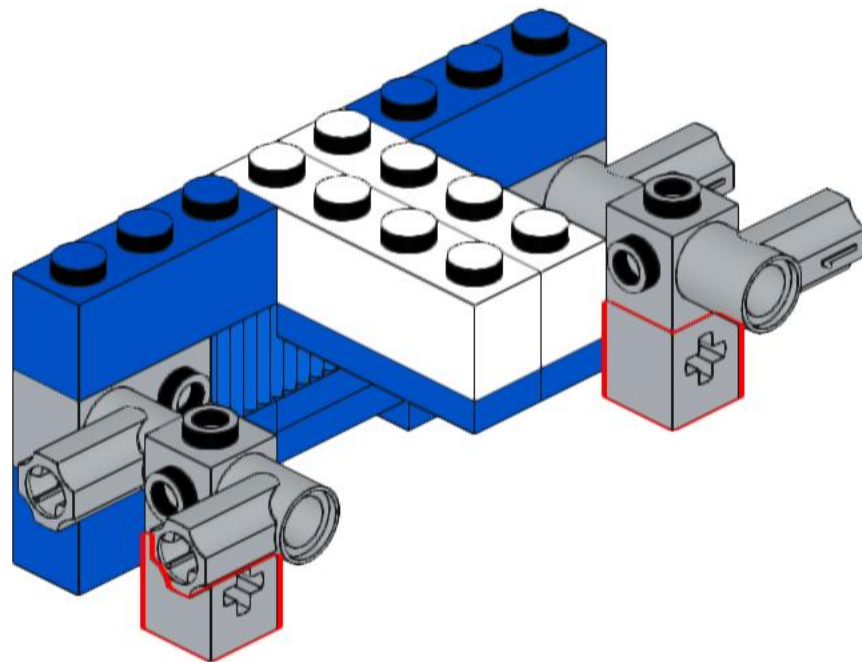
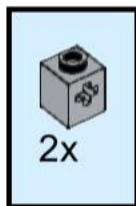

70

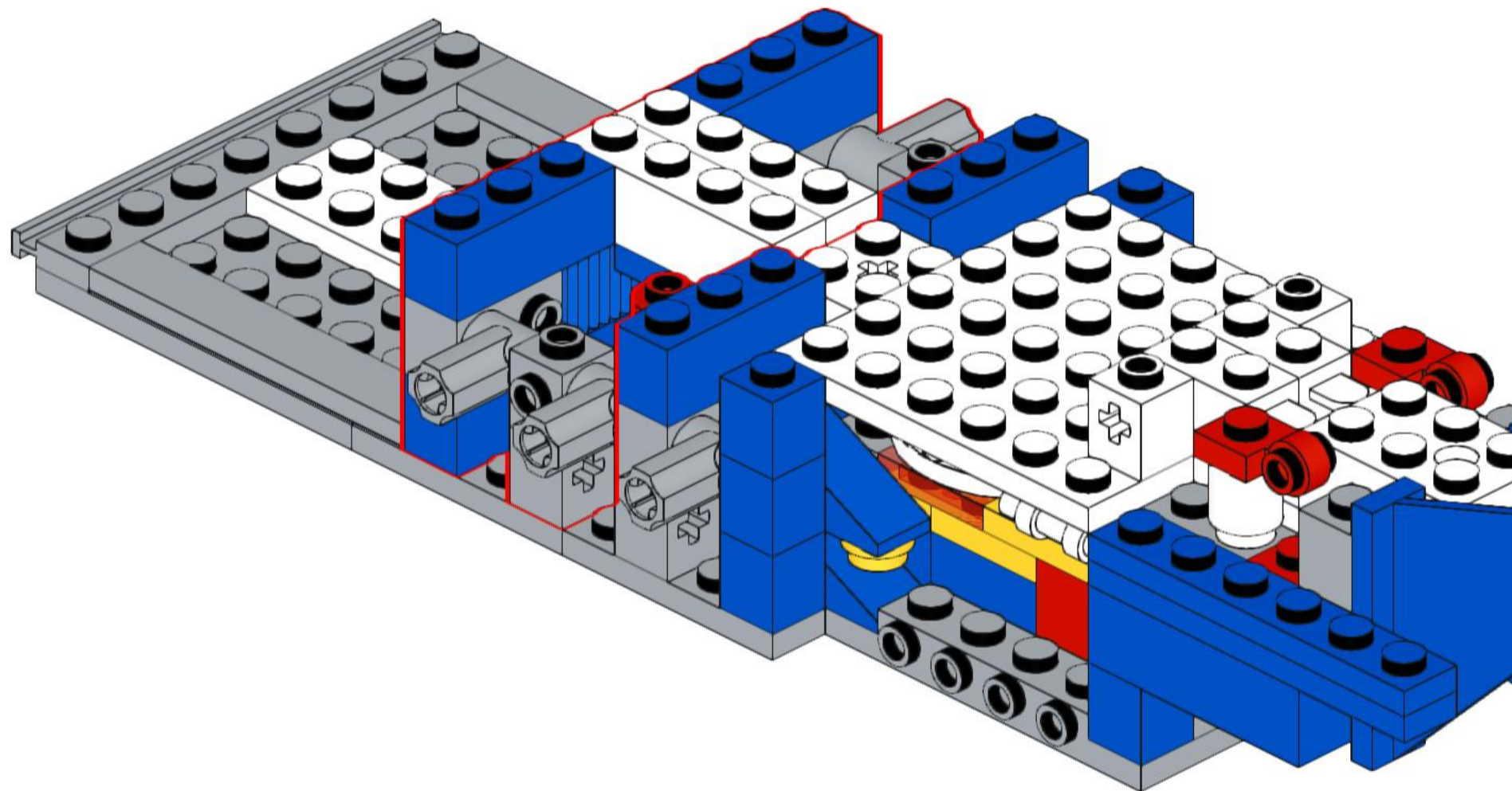

71

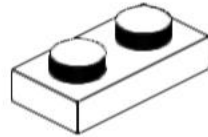
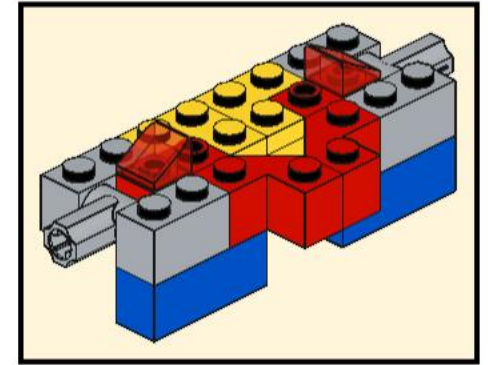
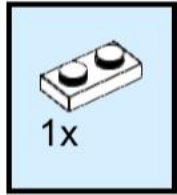

72

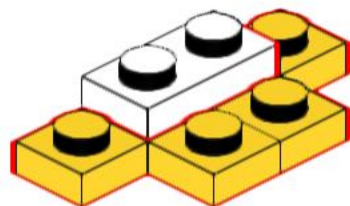
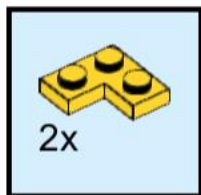

73

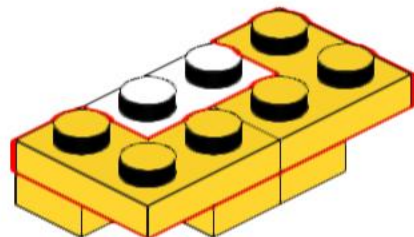
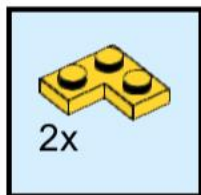

74

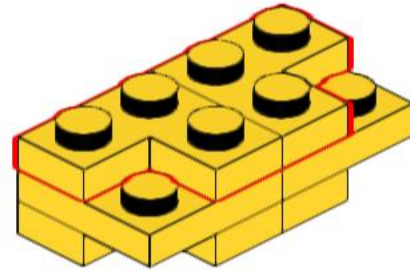
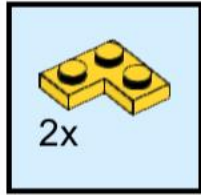

75

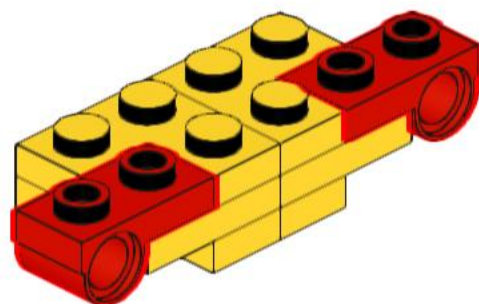
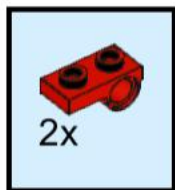

76

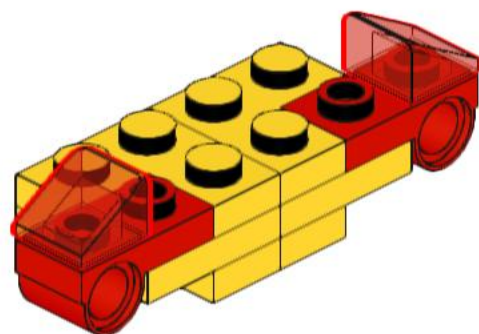

77

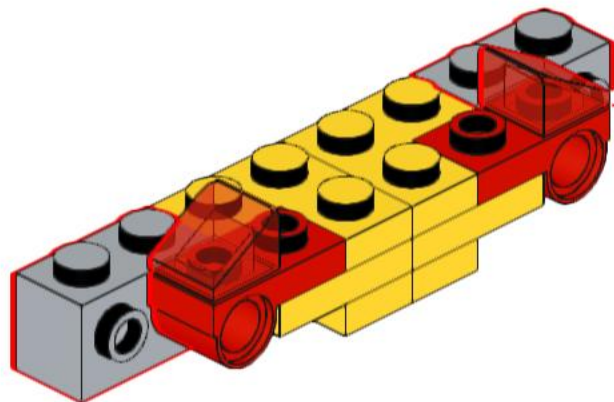
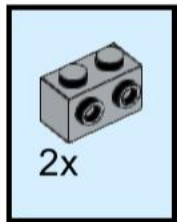

78

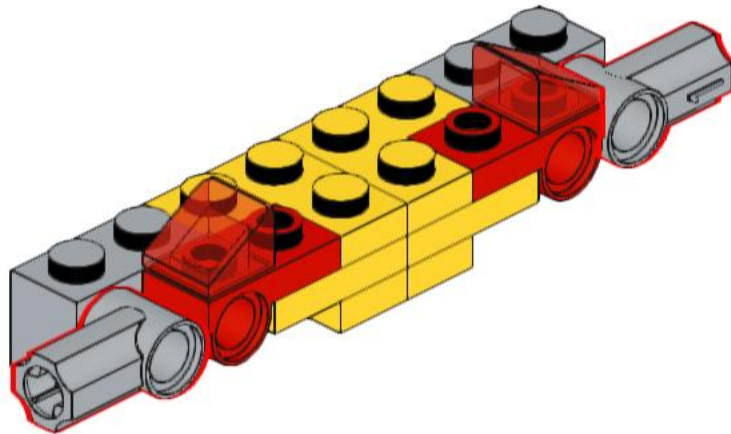

79

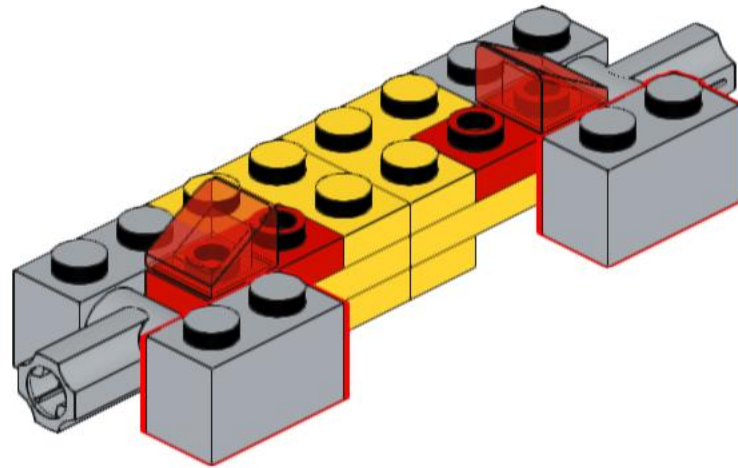
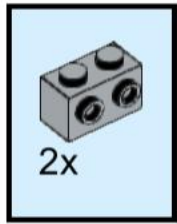

80

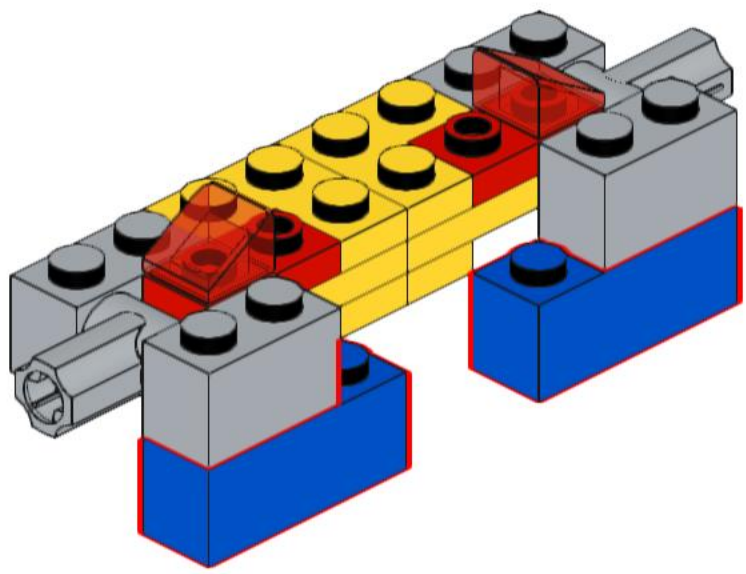
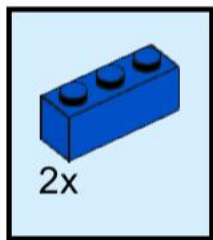

81

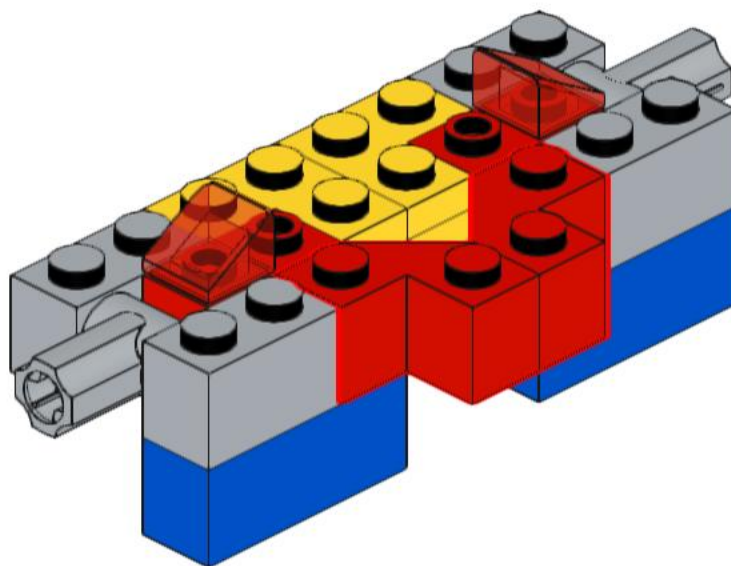
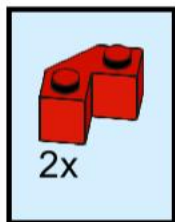

83

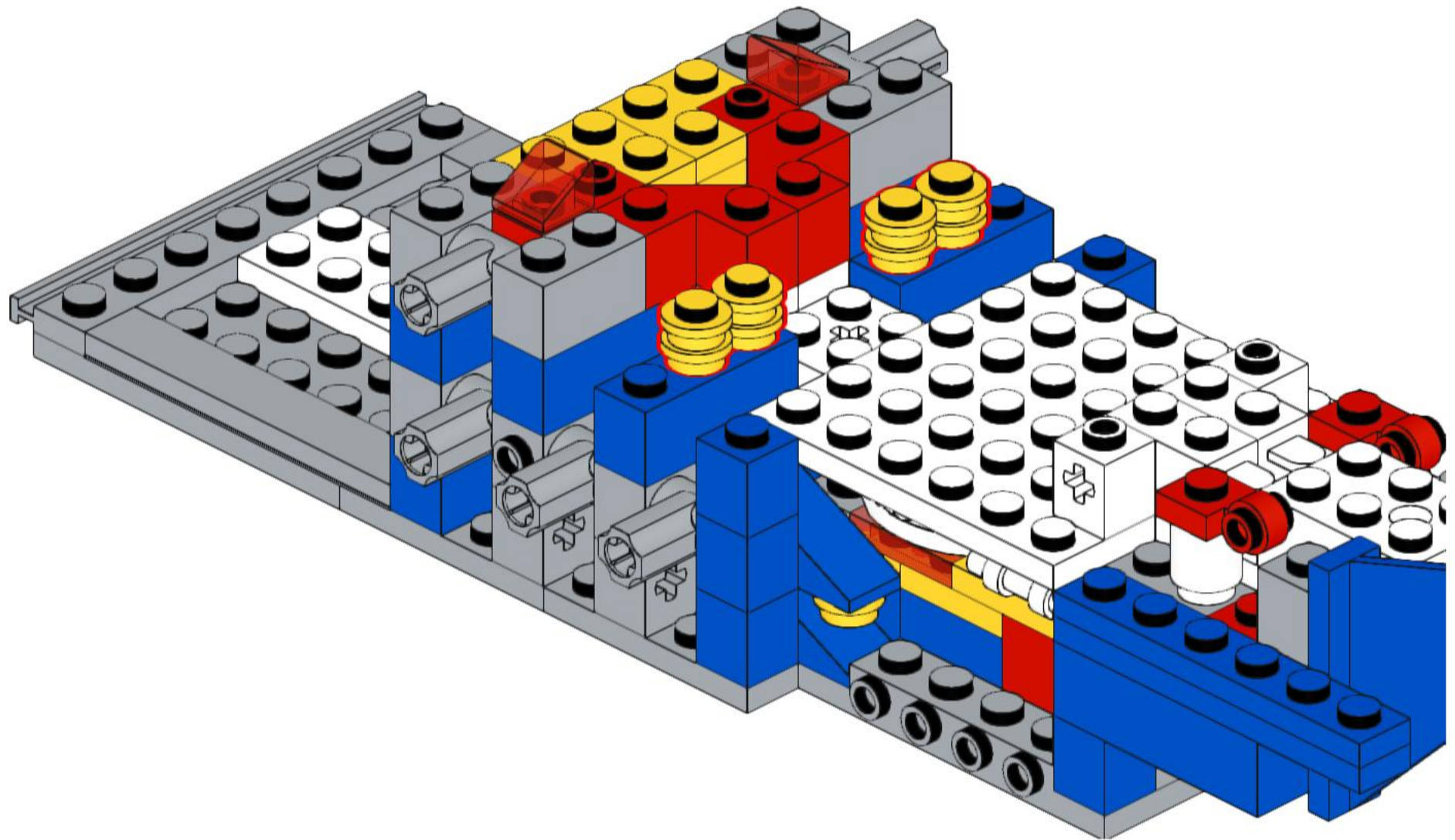

84

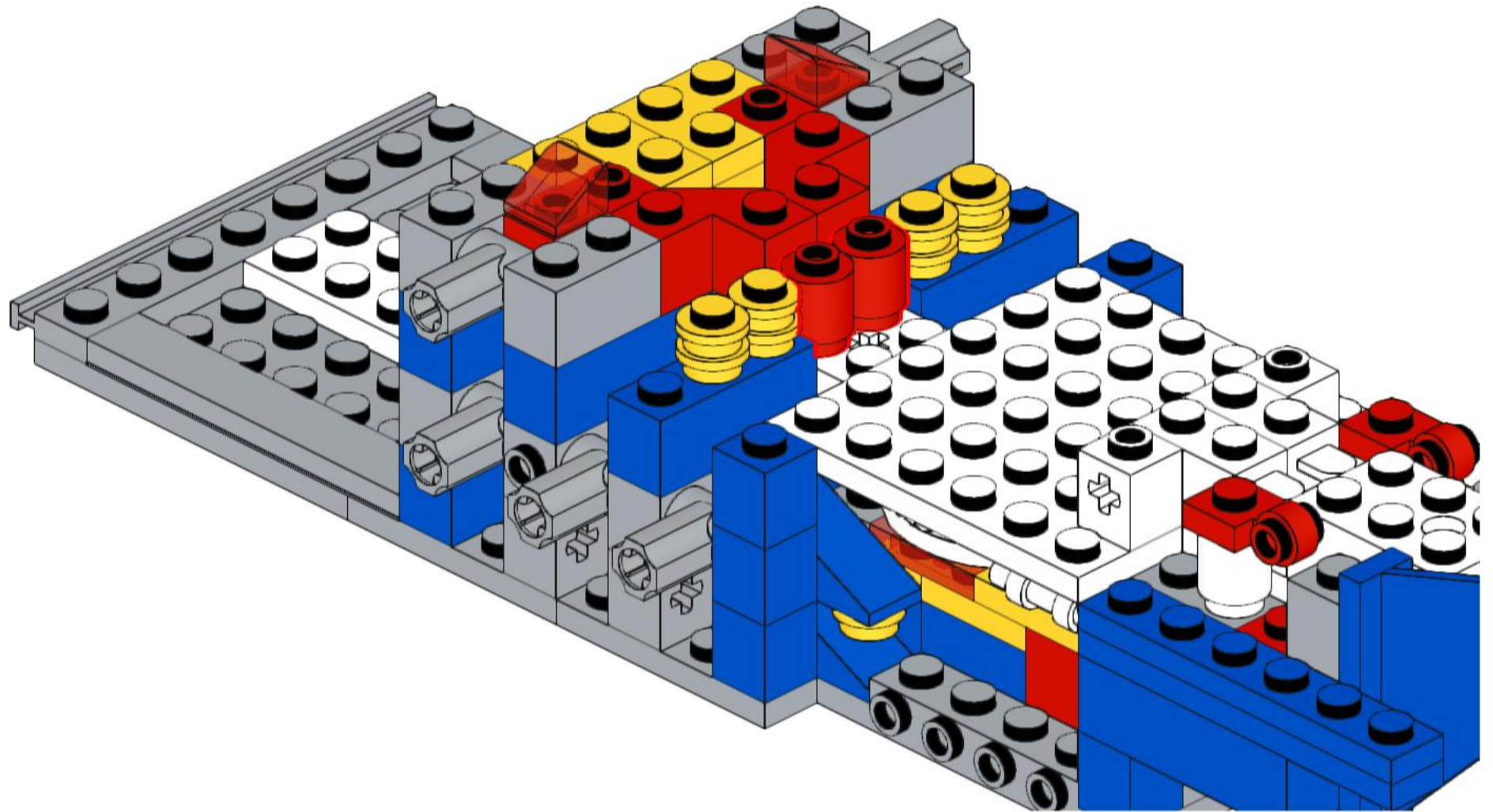

85

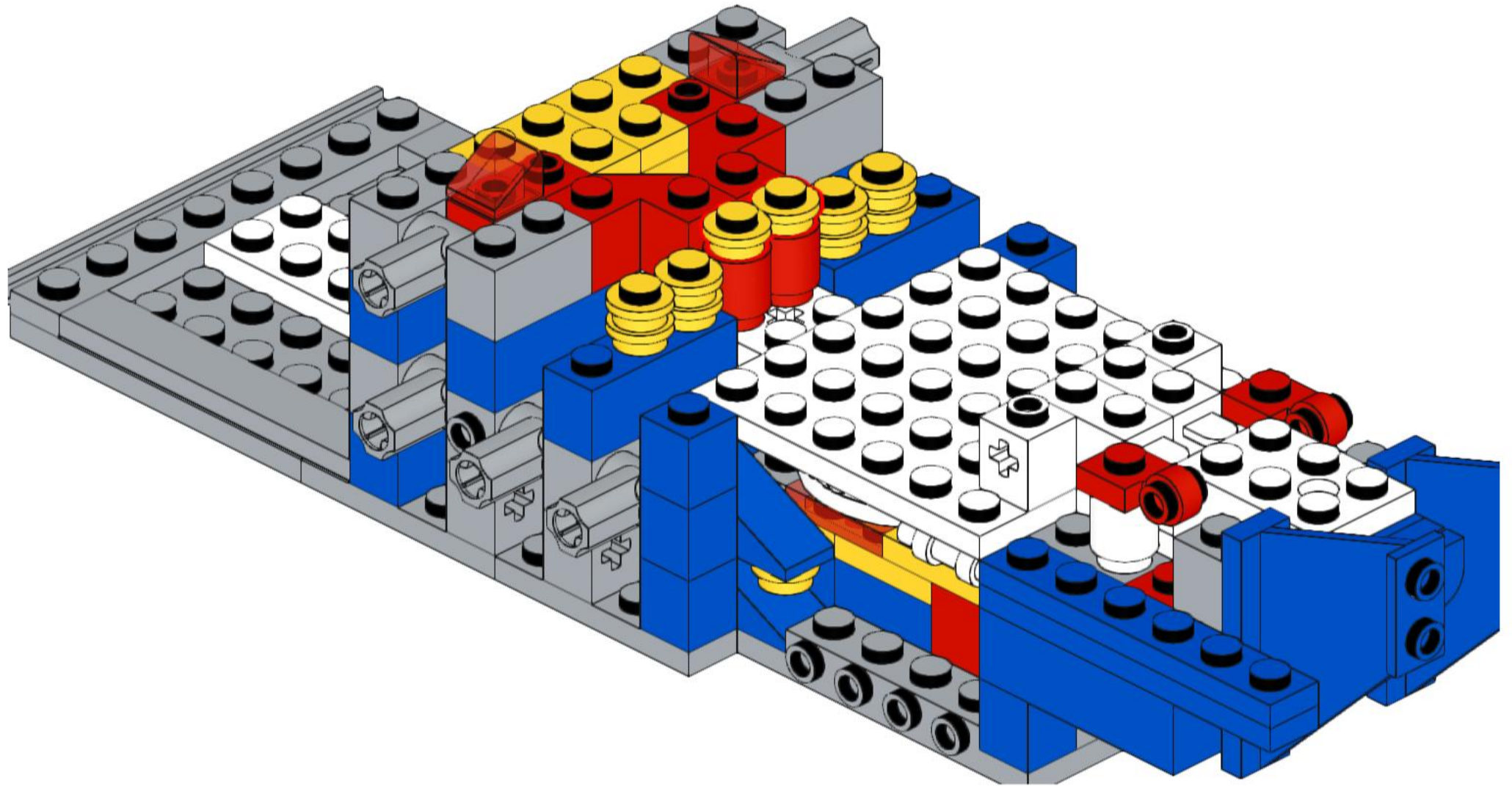

86

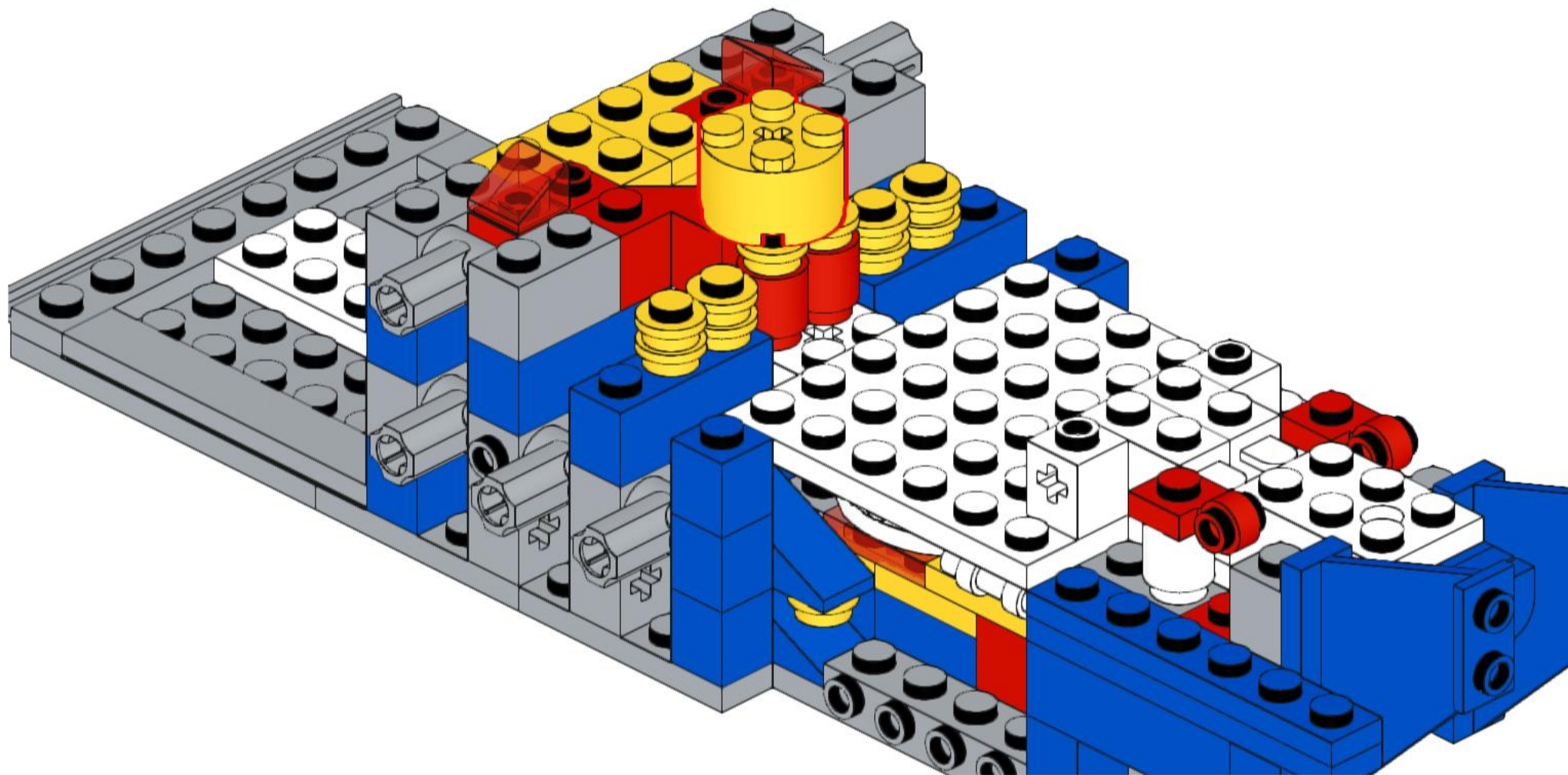
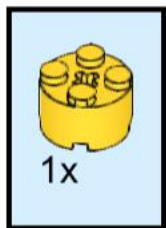

87

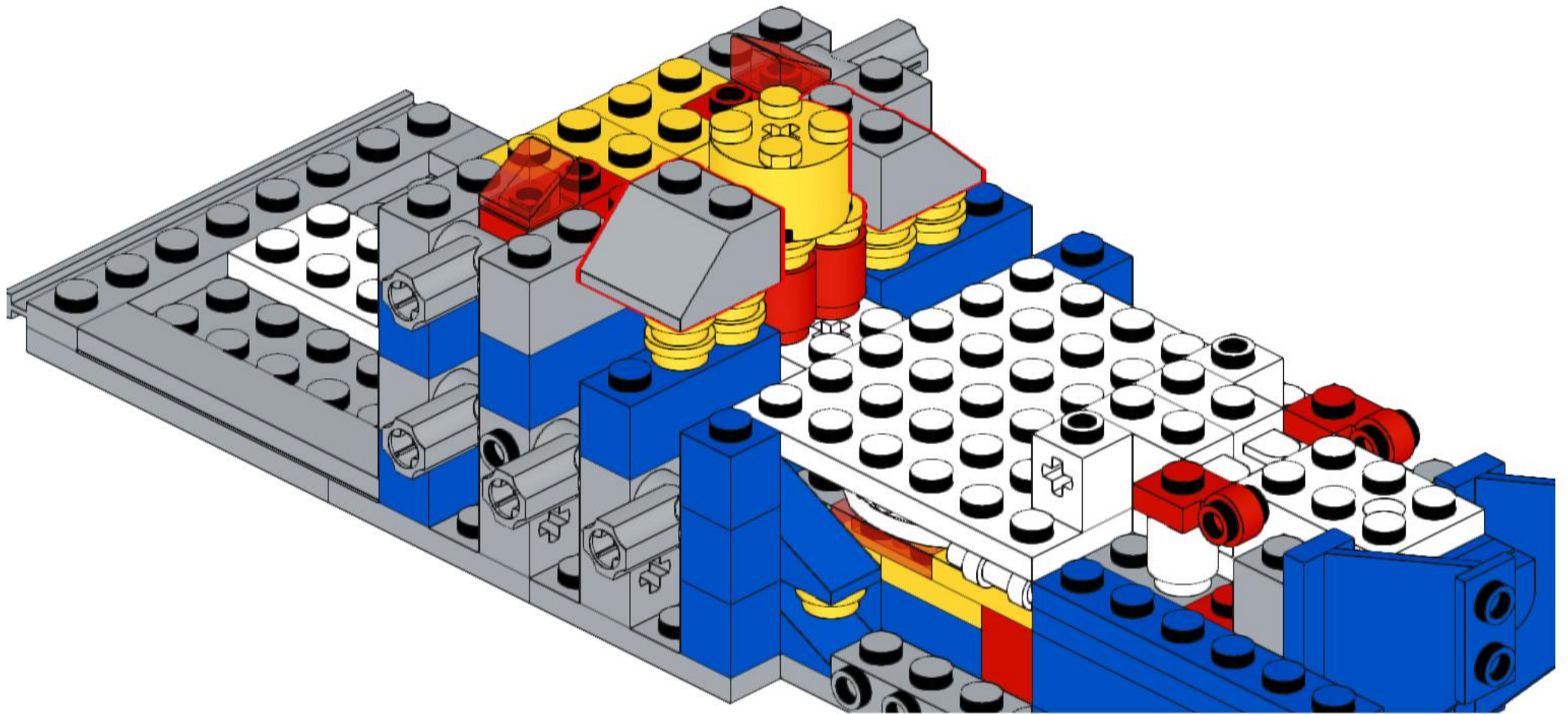
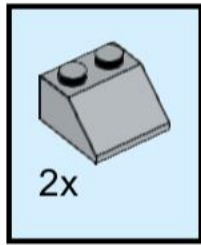

88

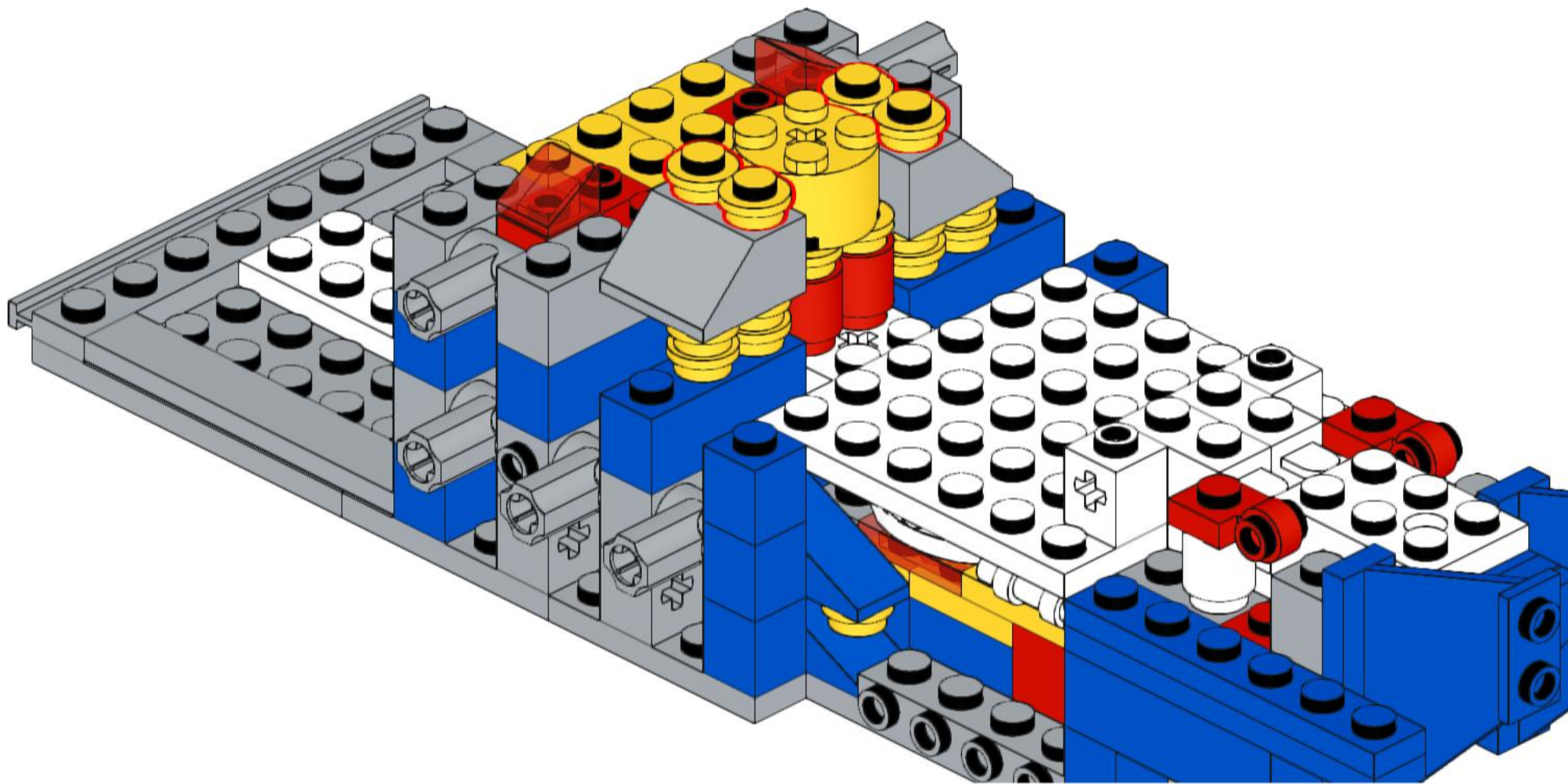

89

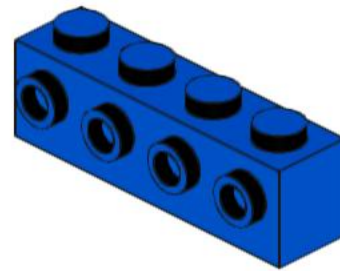
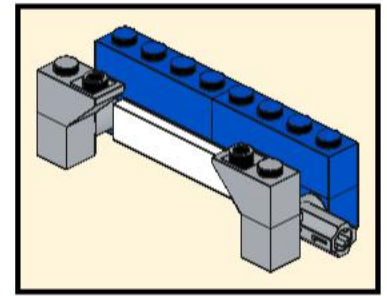
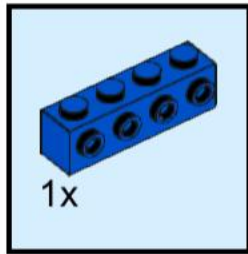

90

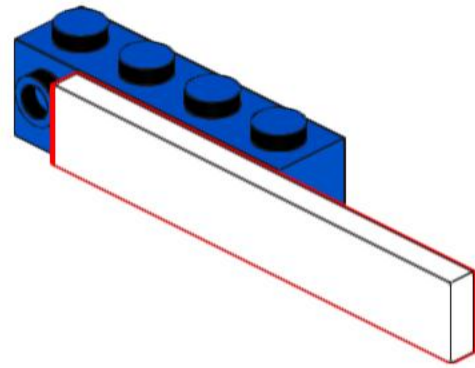
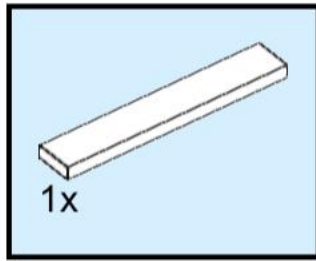

91

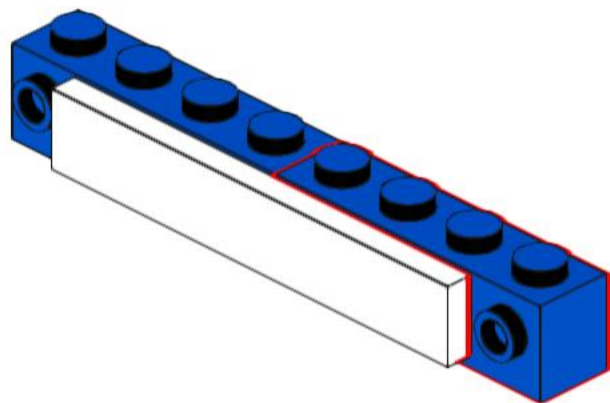
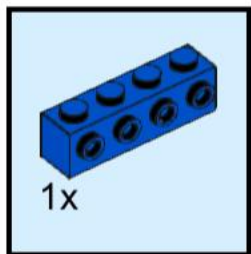

92

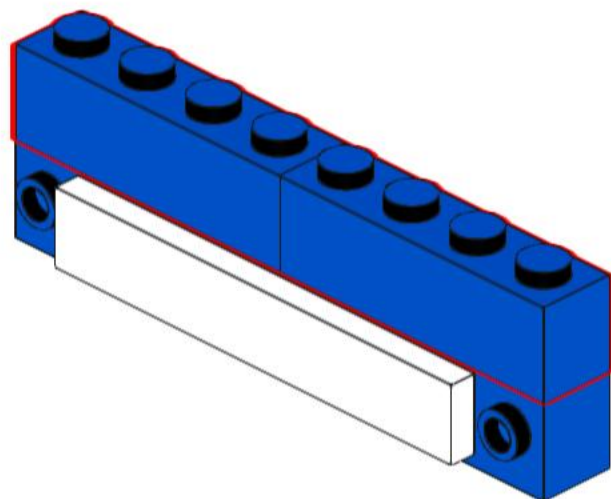
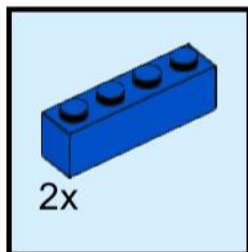

93

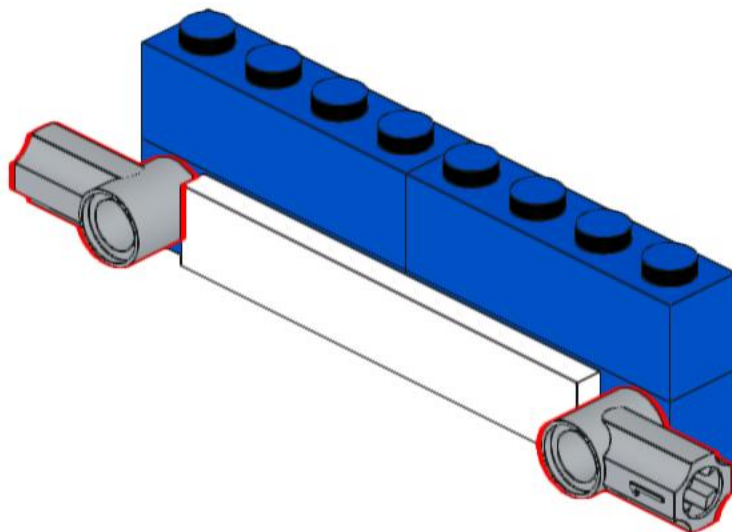

94

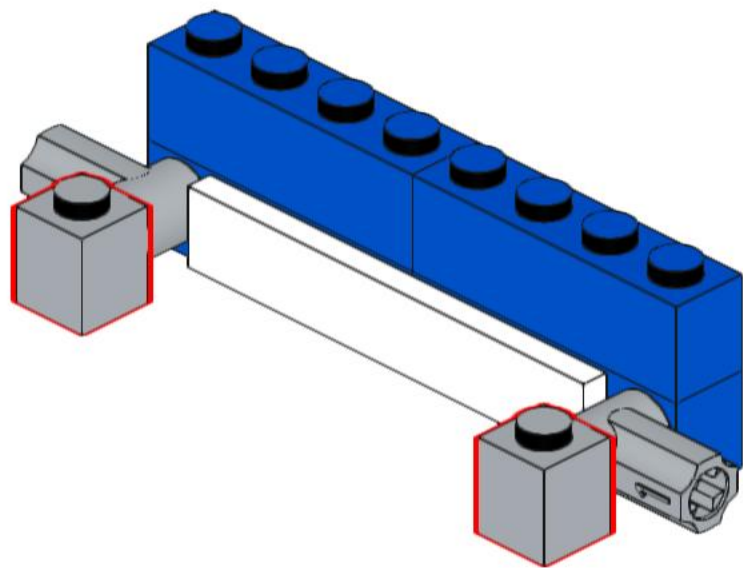
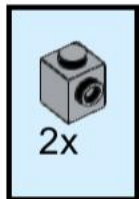

95

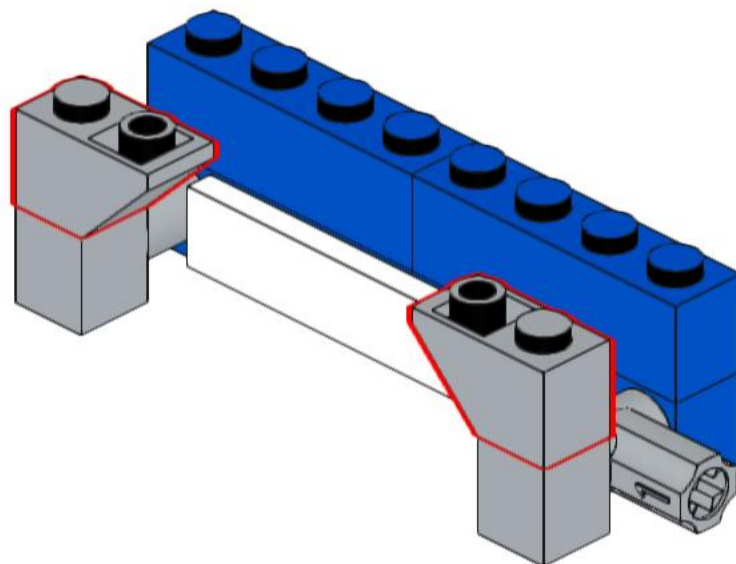
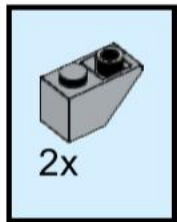

96

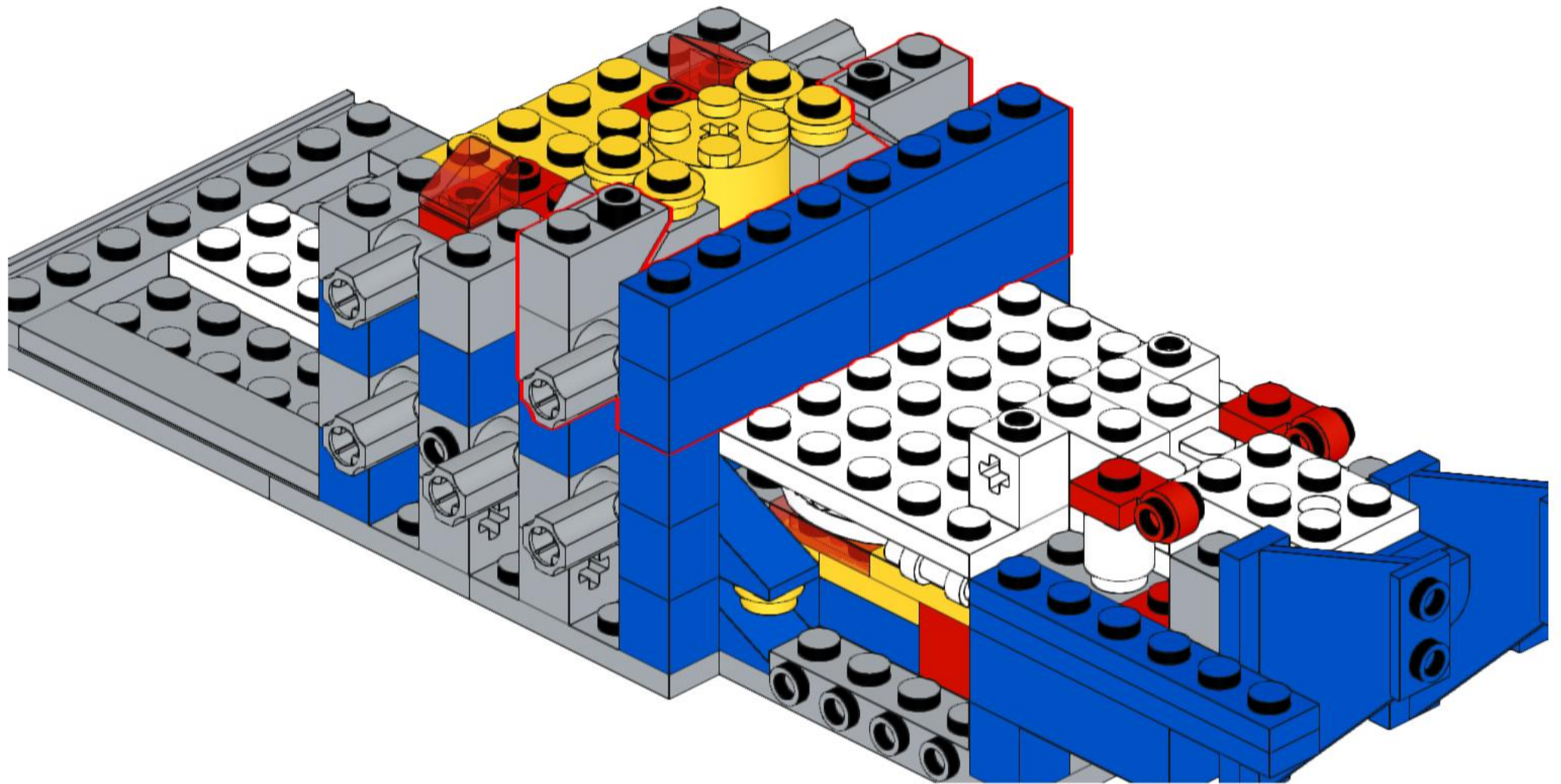

97

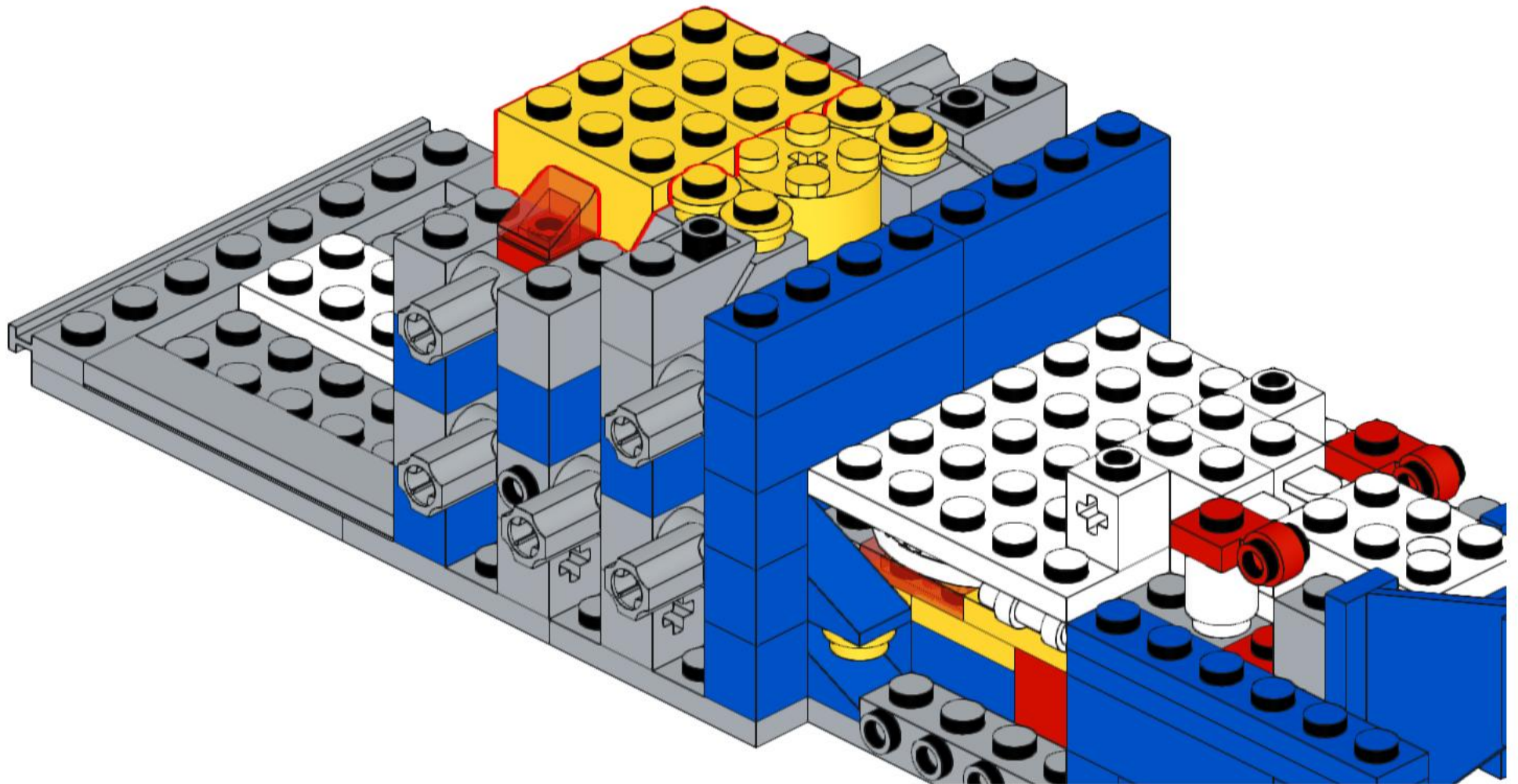
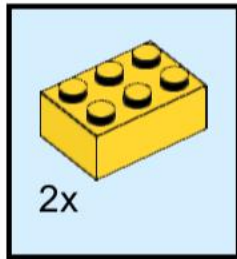

98

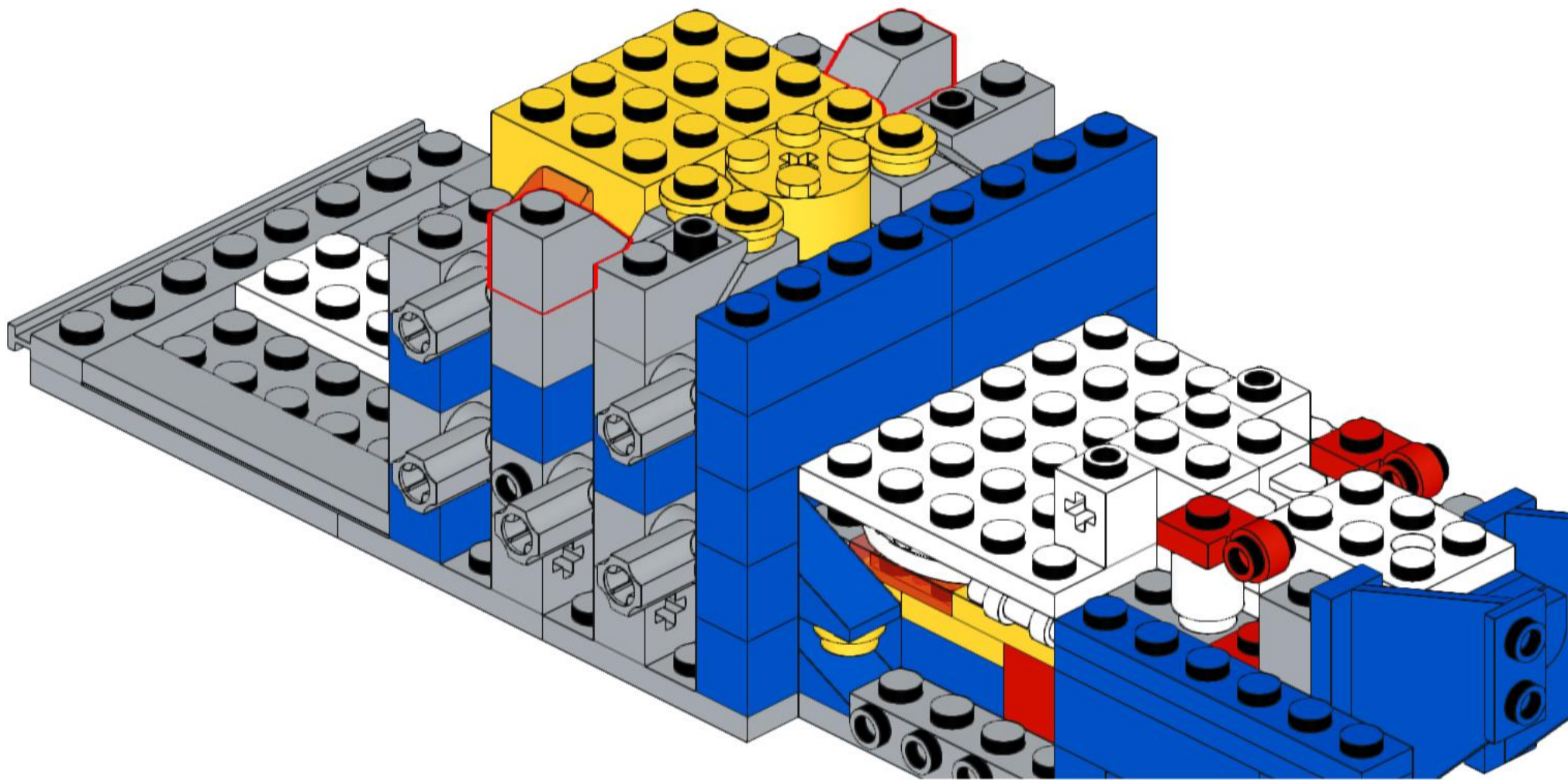
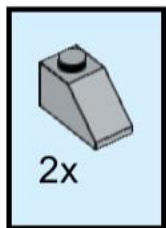

99

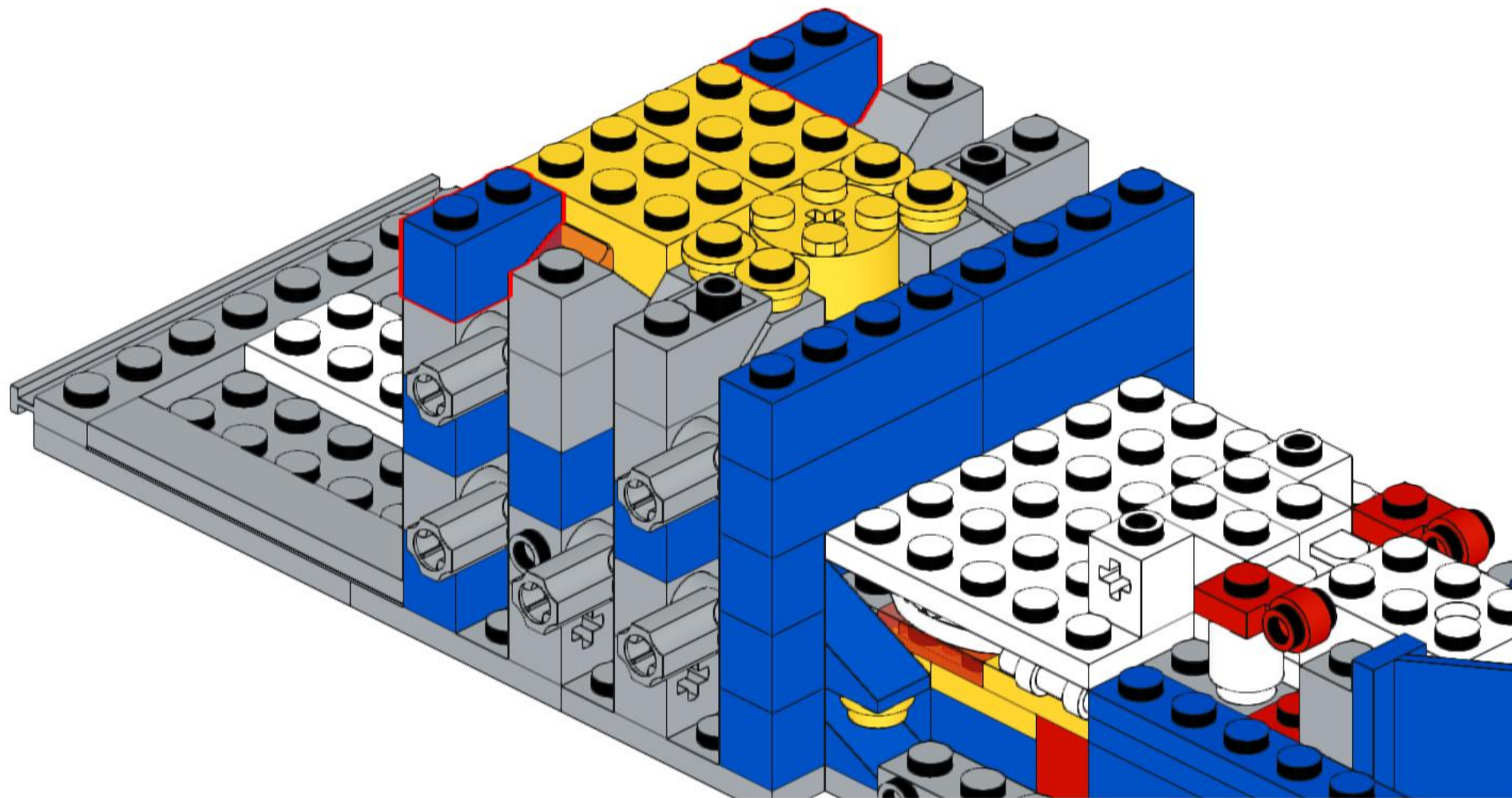
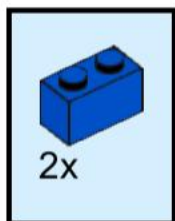

100

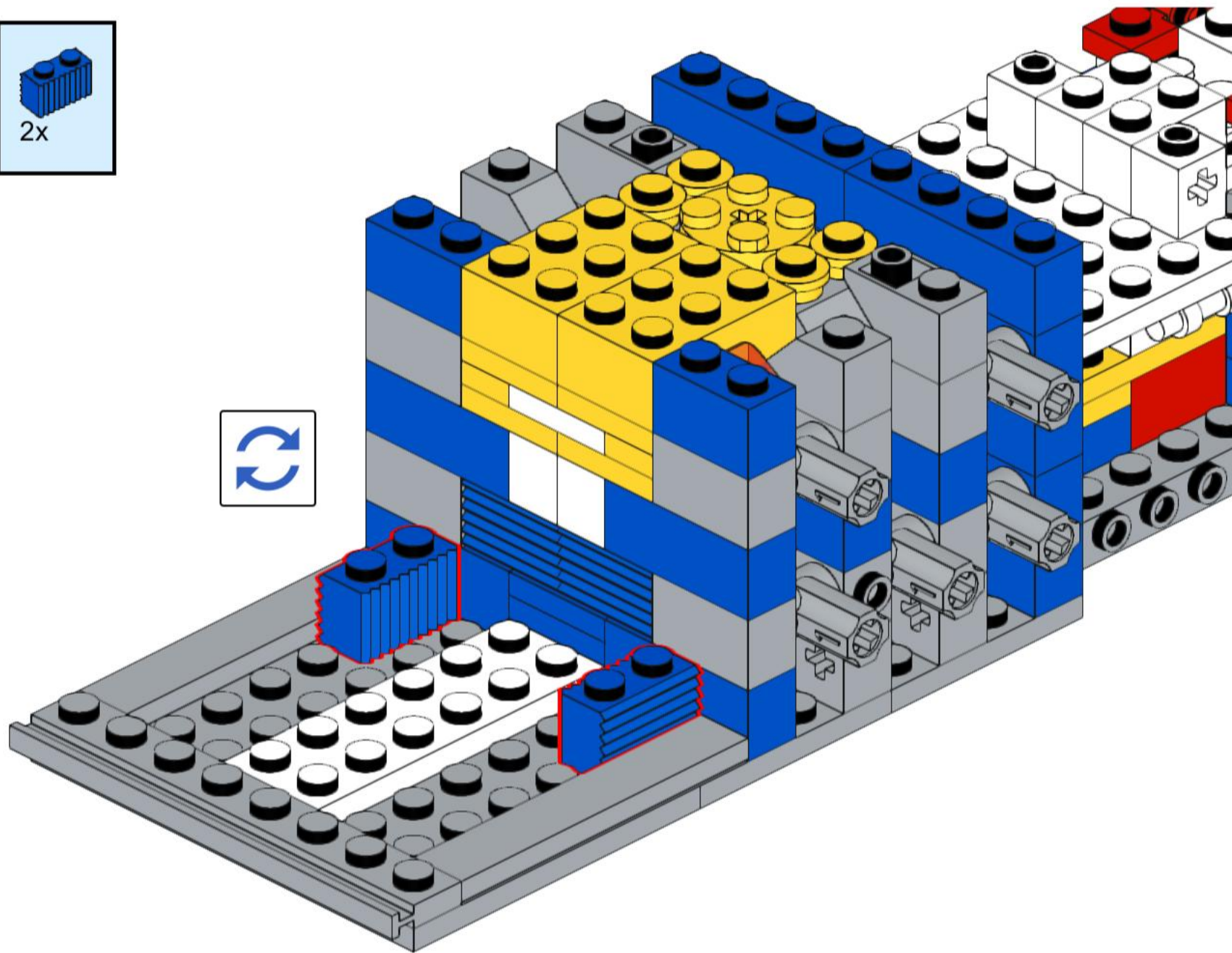
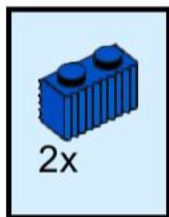

101

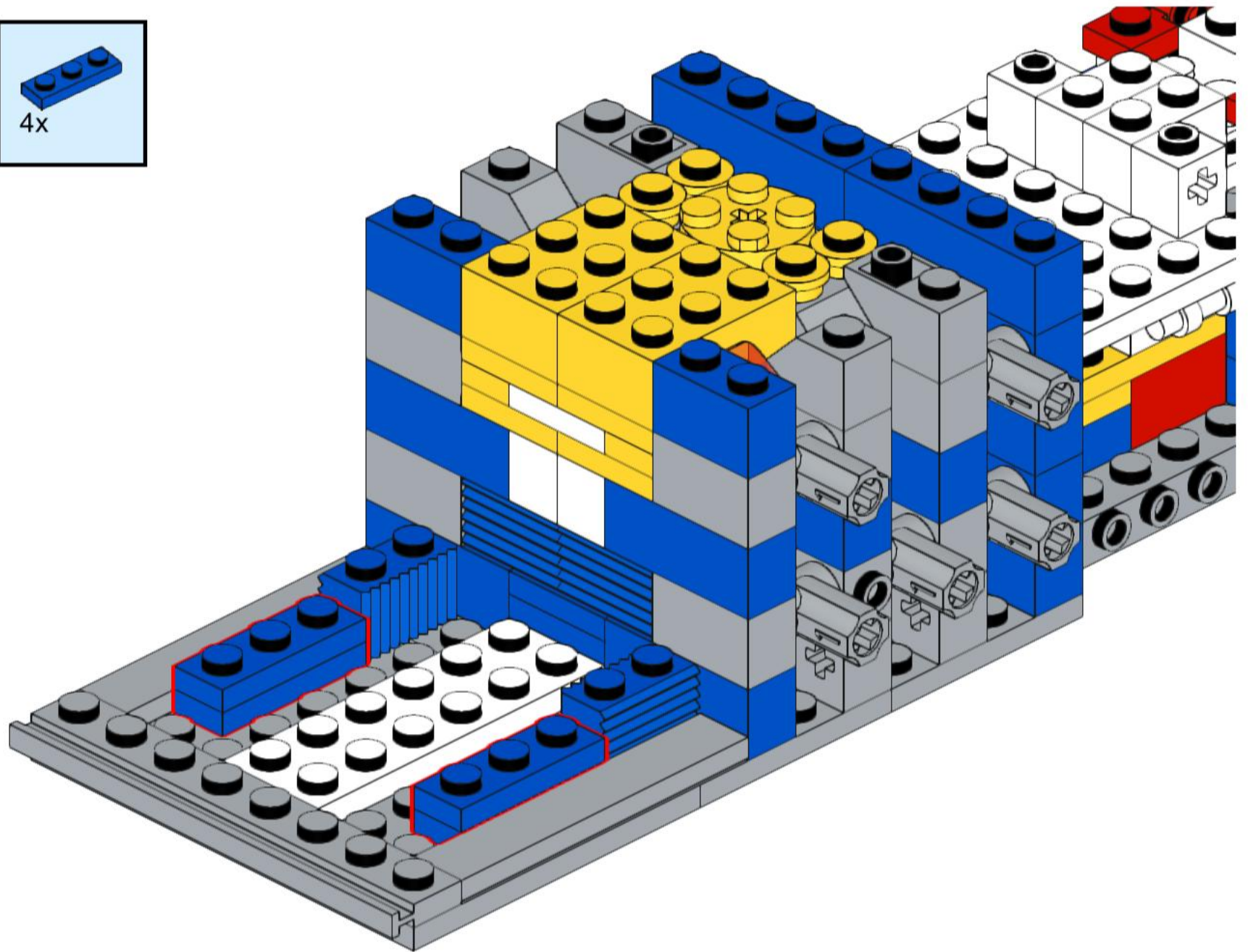
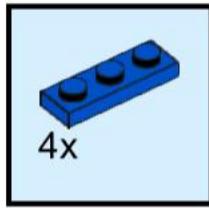

102

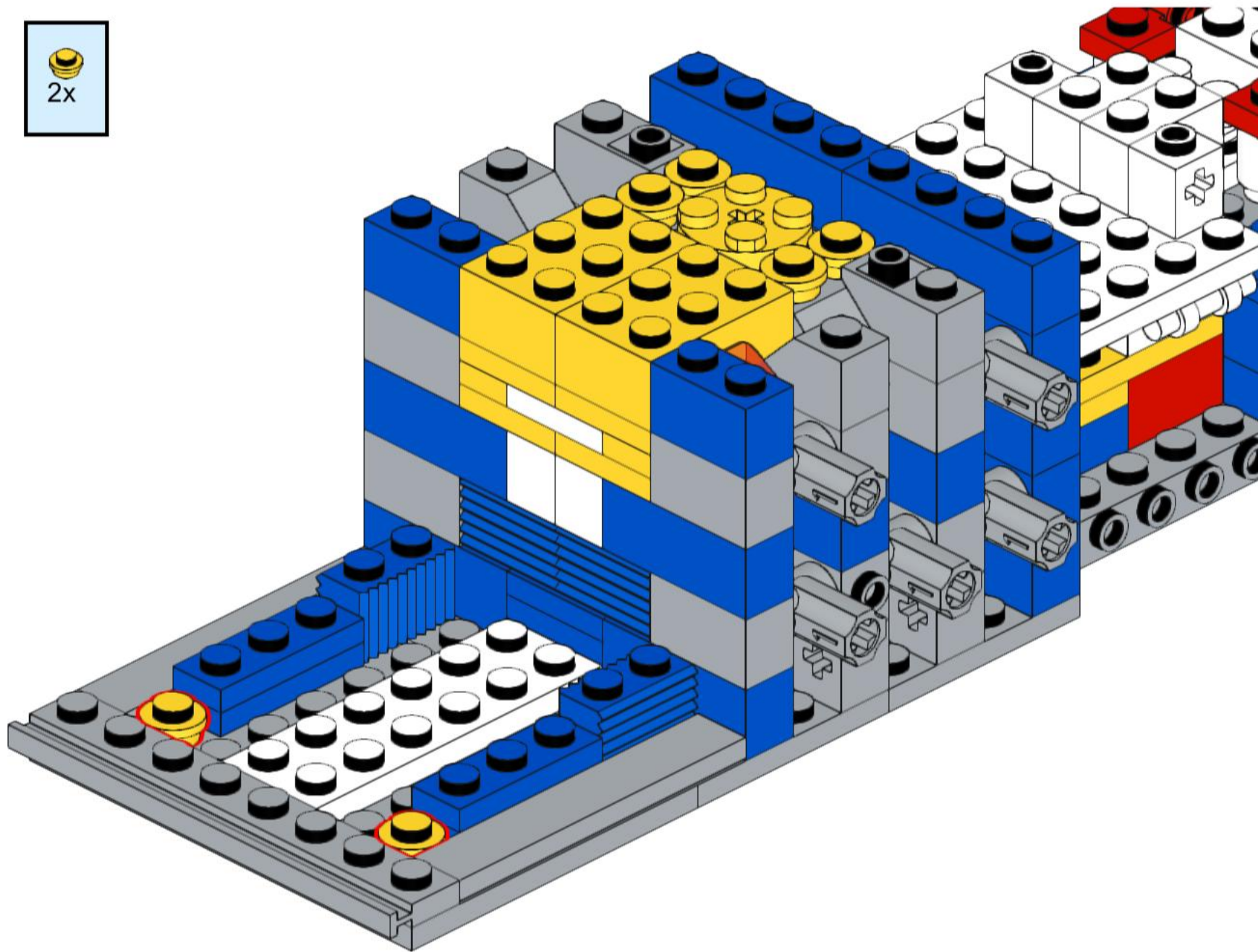

103

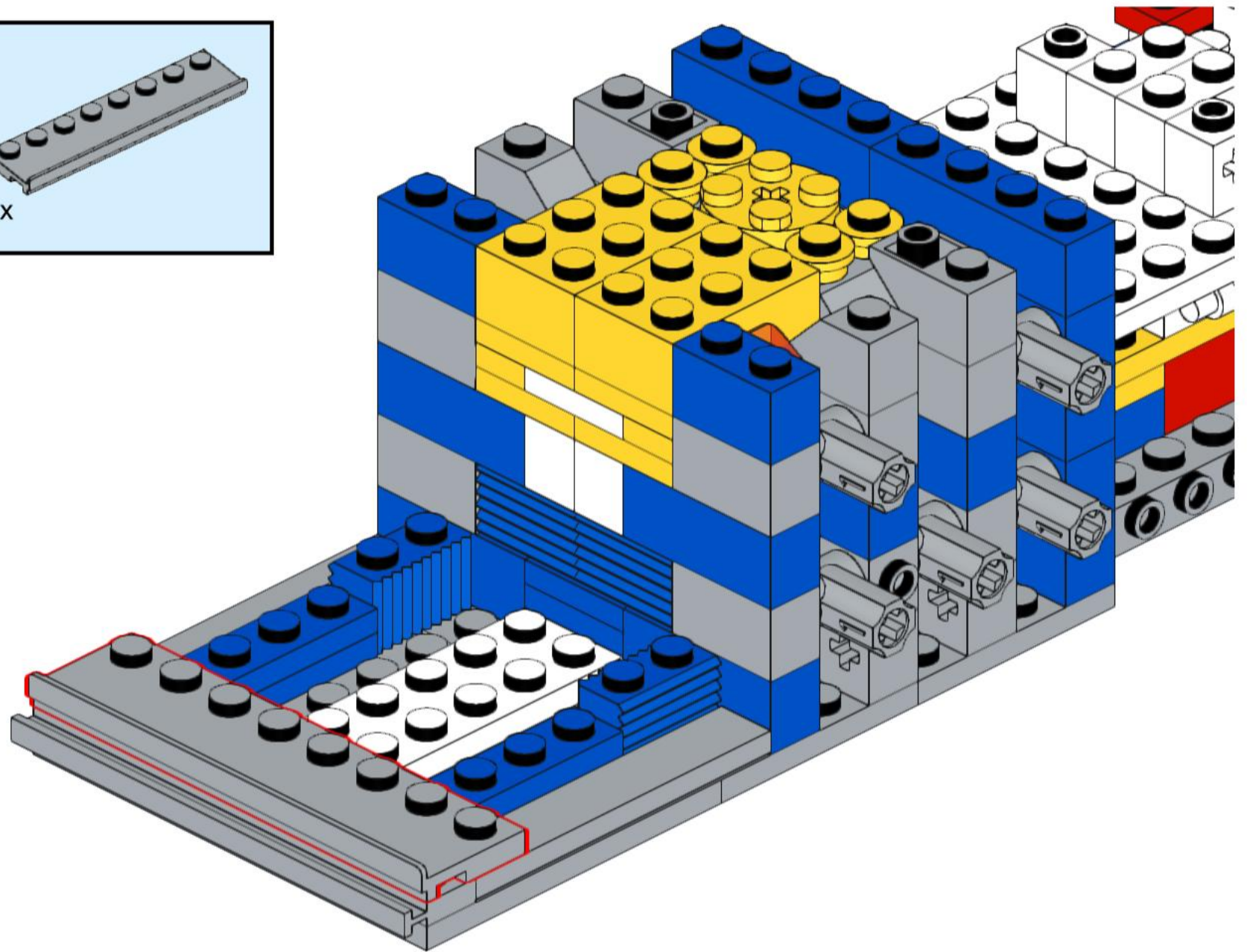
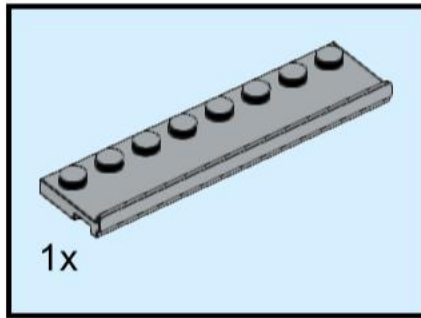

104

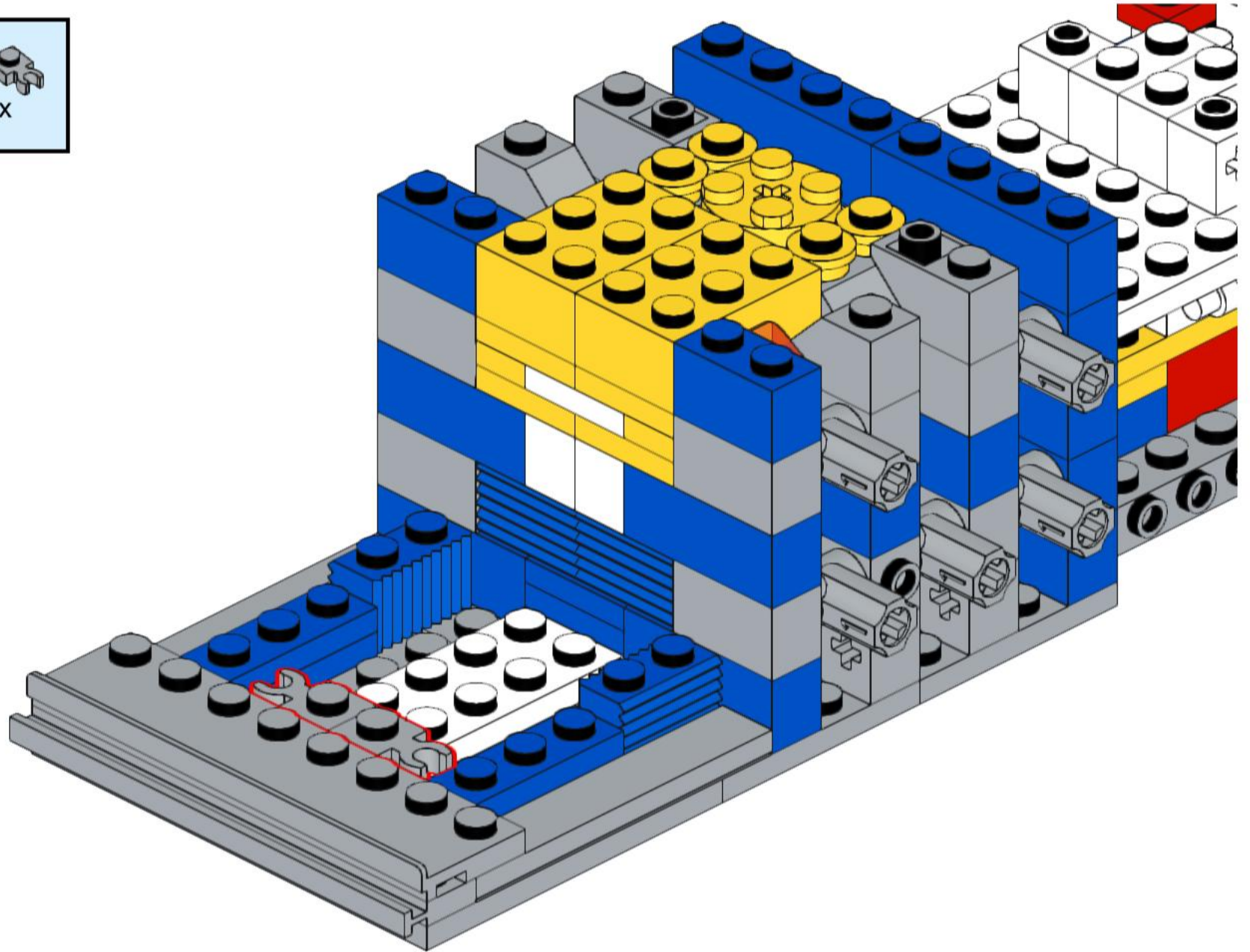
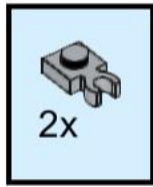

105

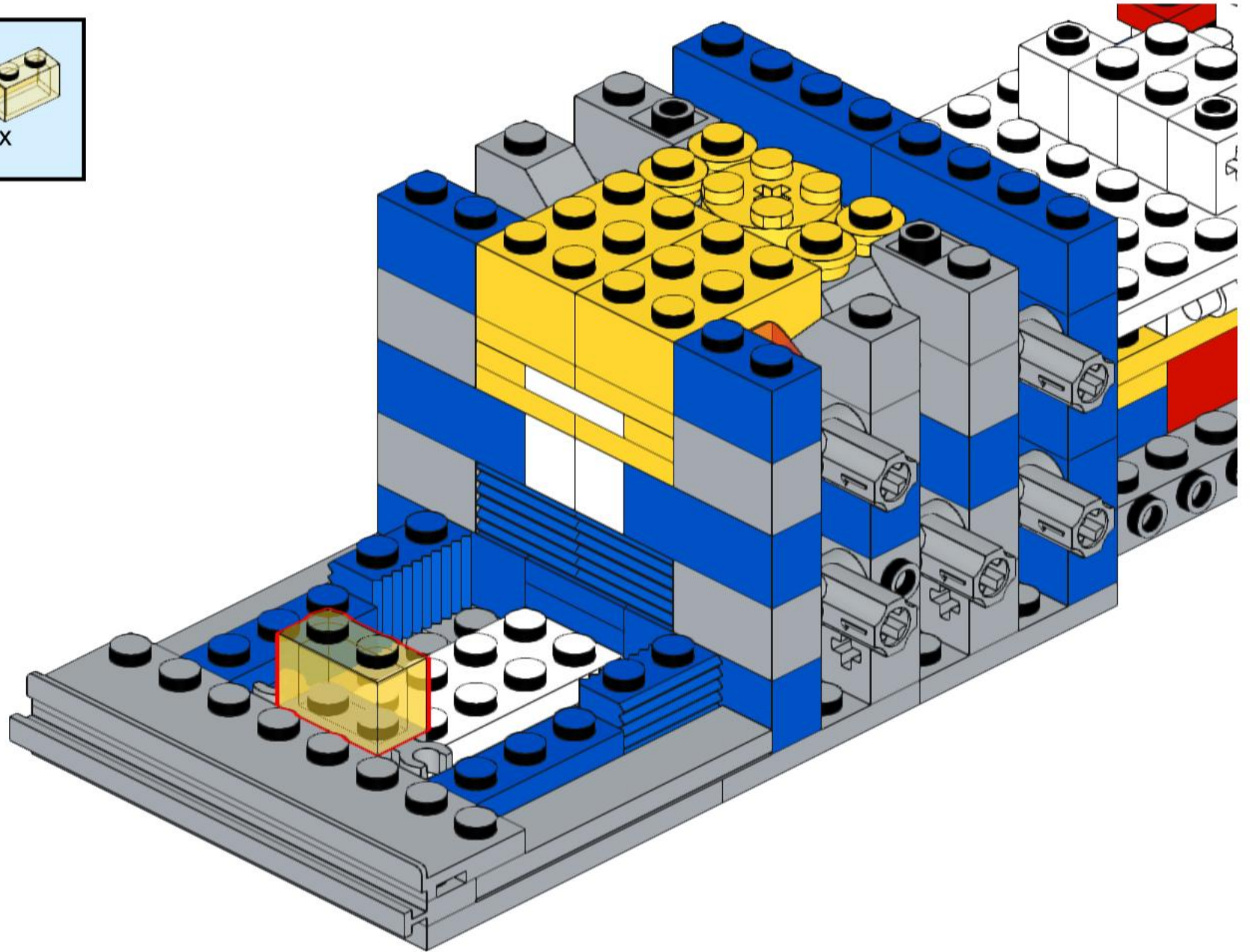
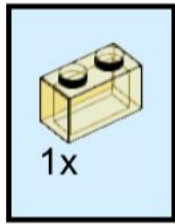

106

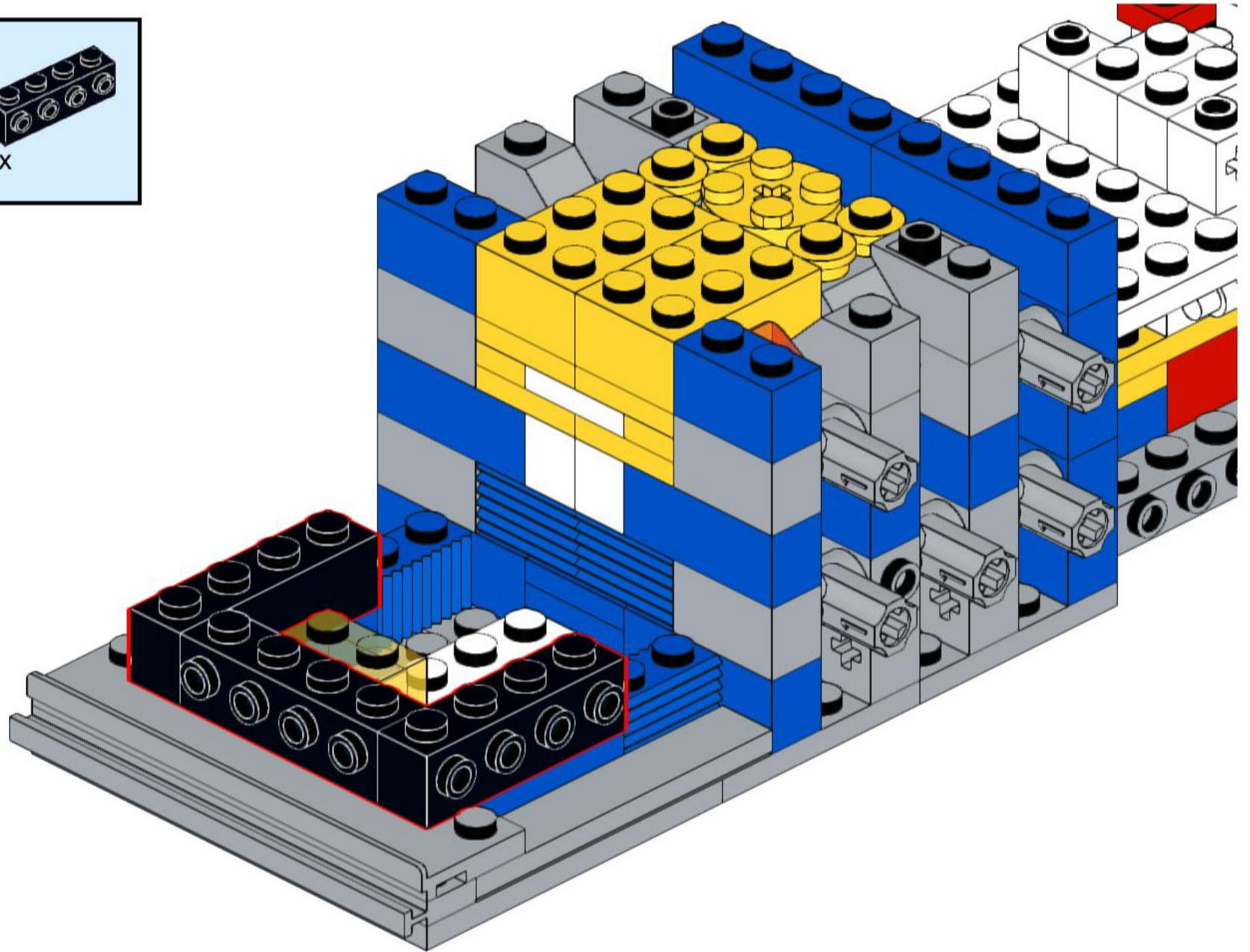
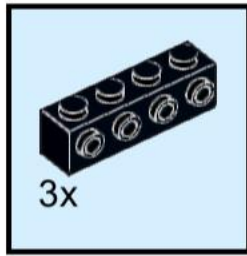

107

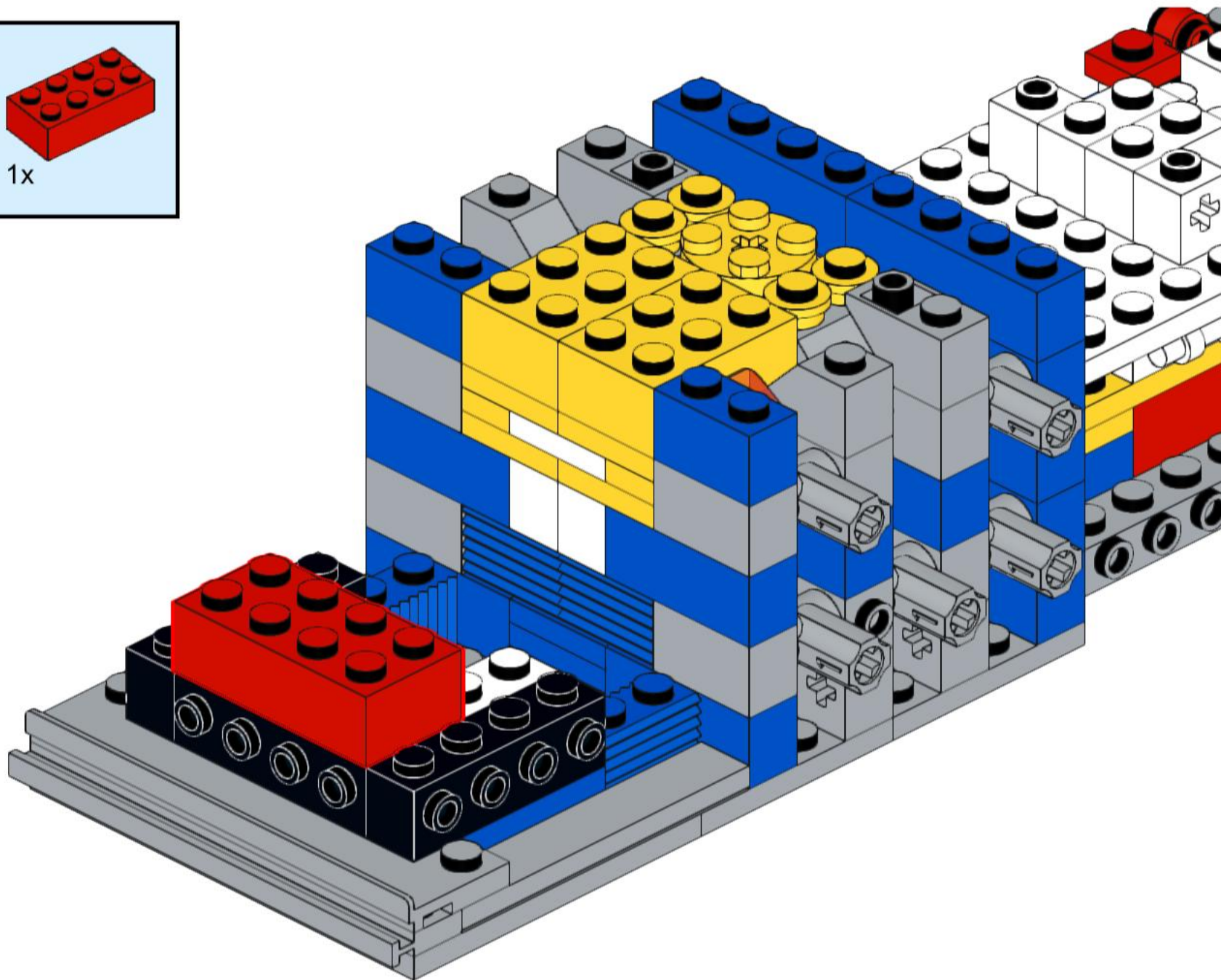
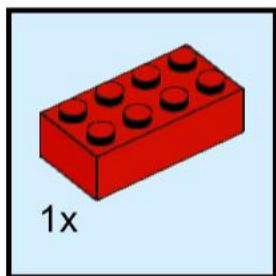

108

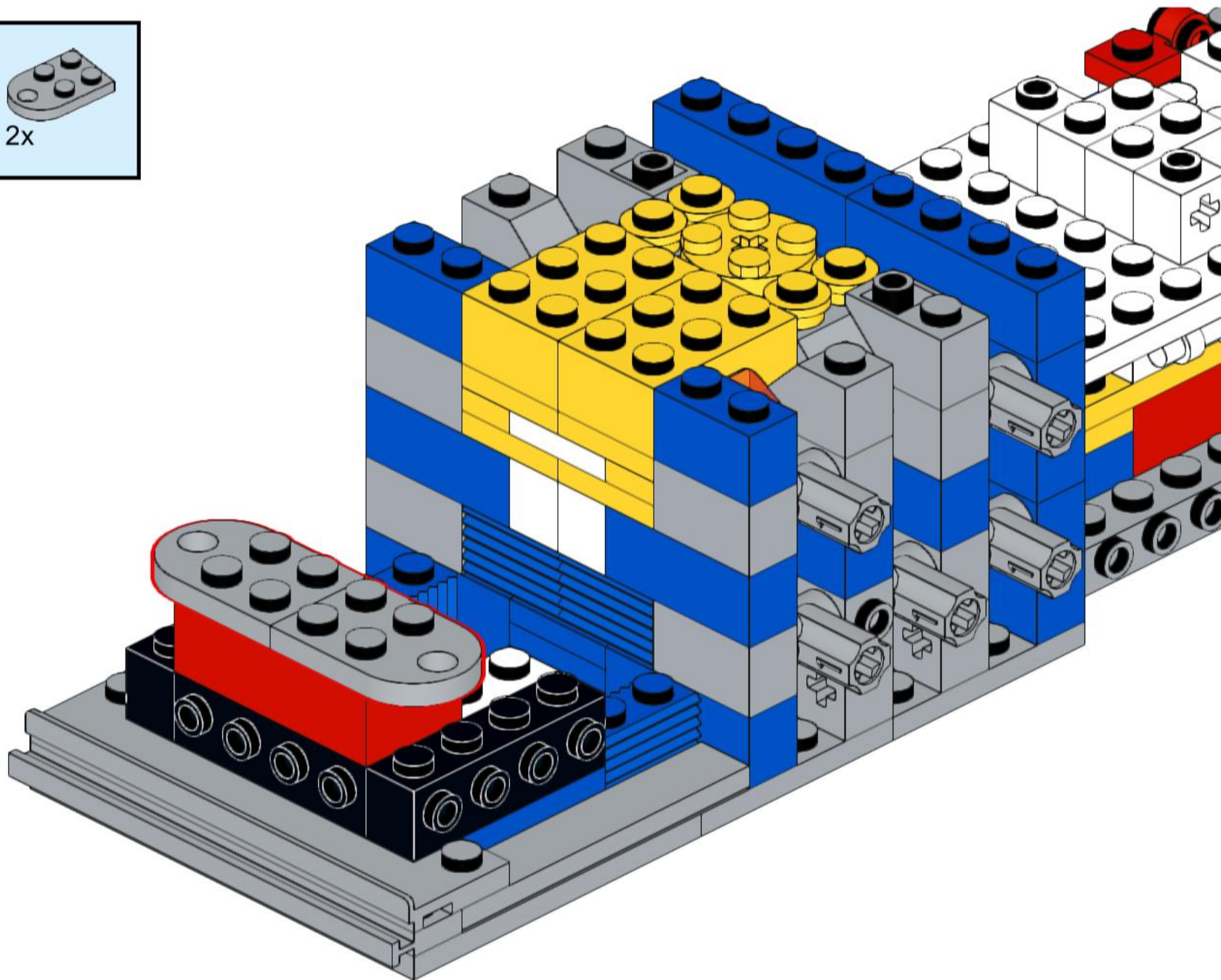
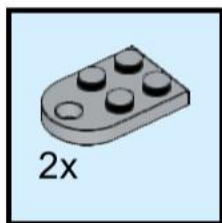

109

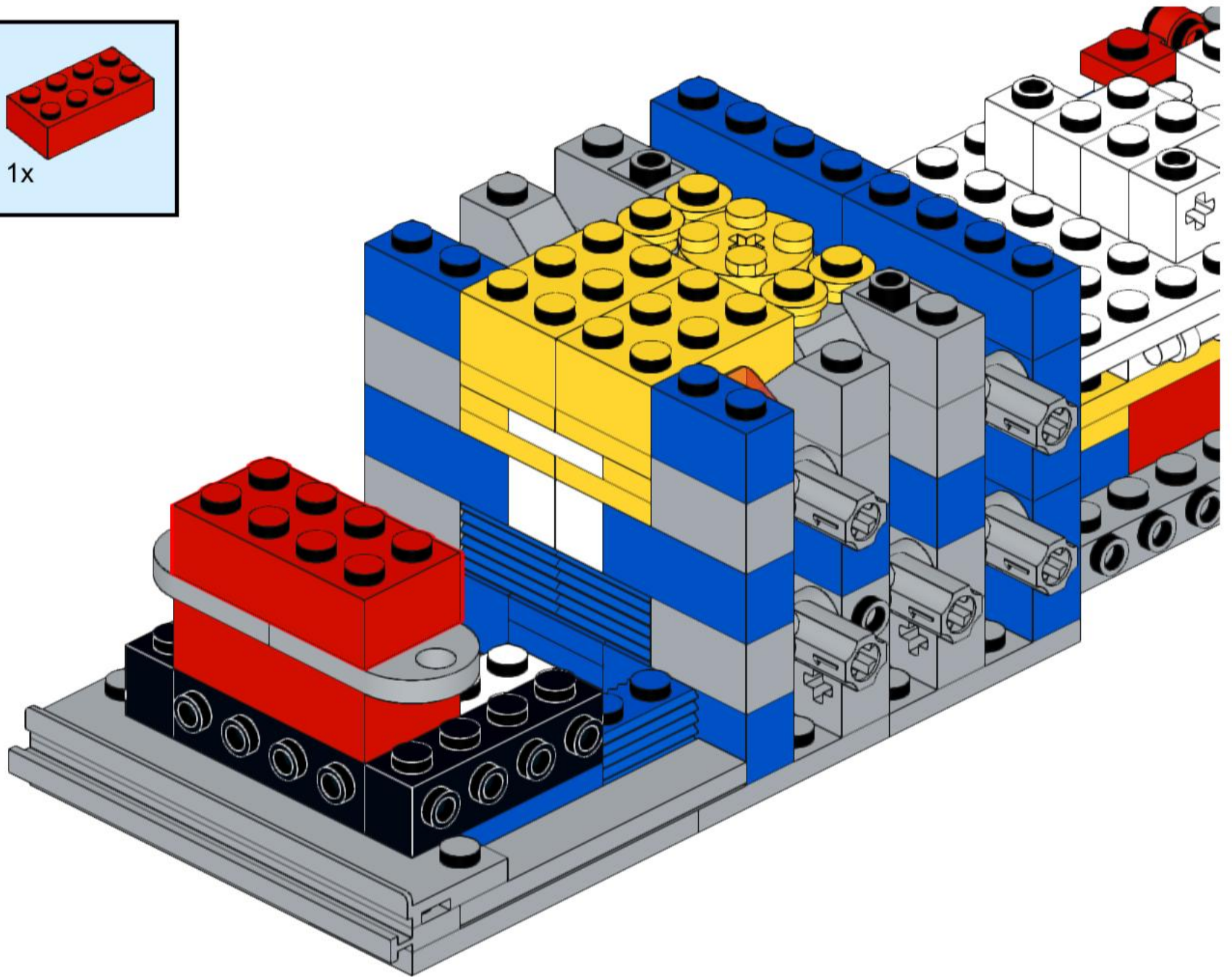
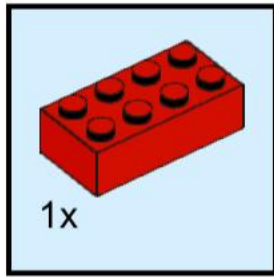

110

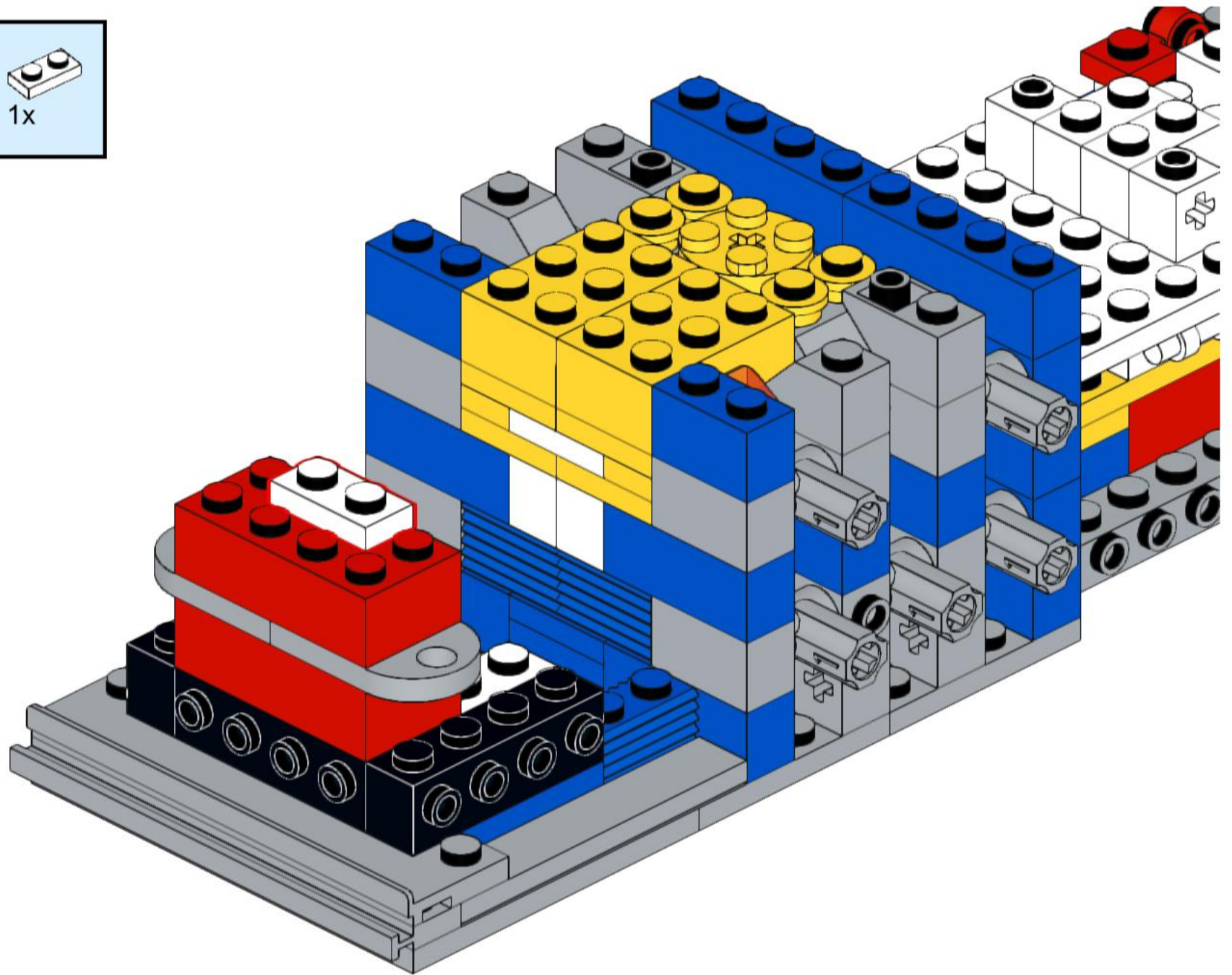
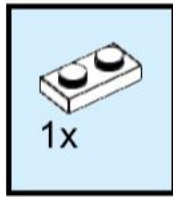

111

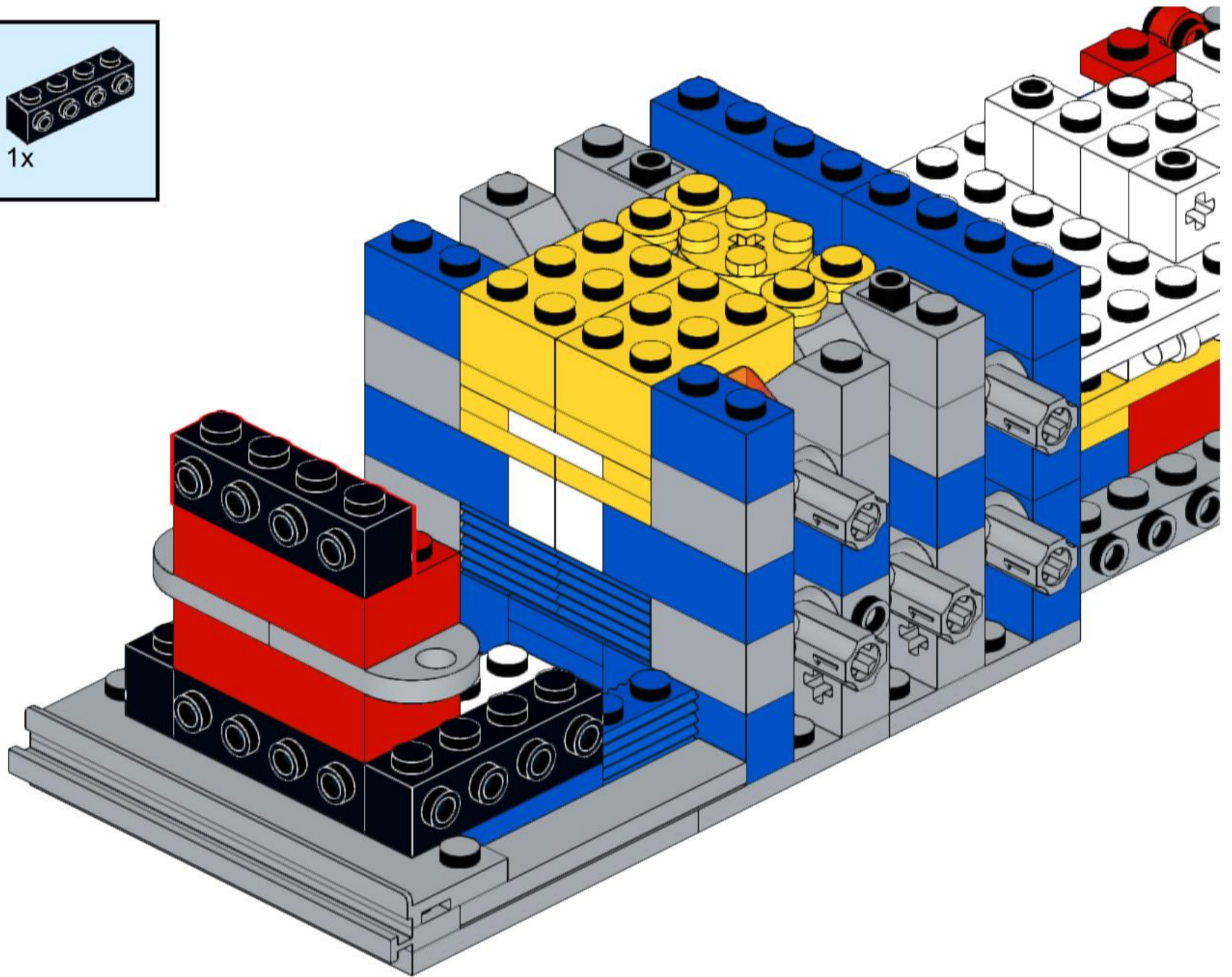
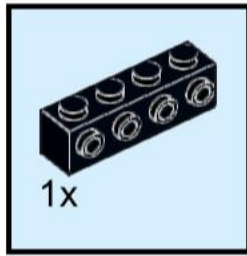

112

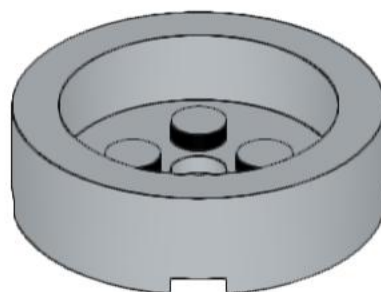
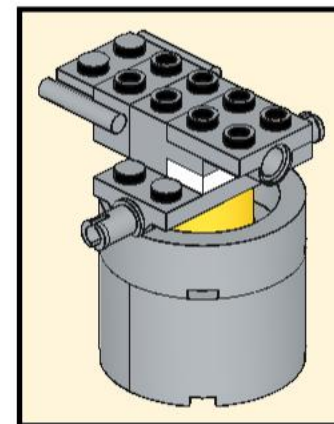
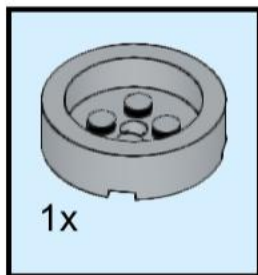

113

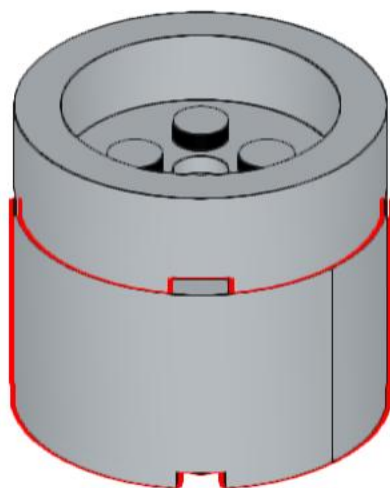
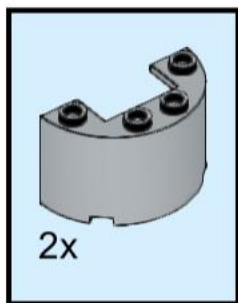

114

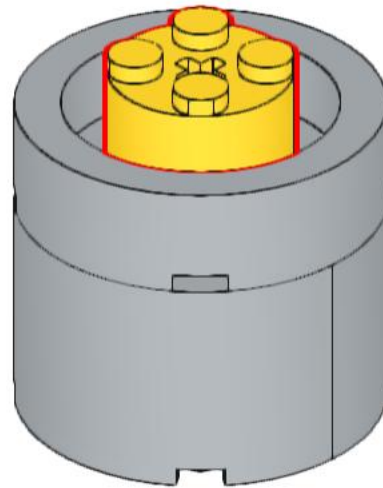
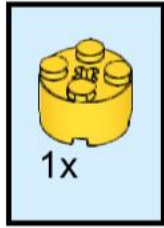

115

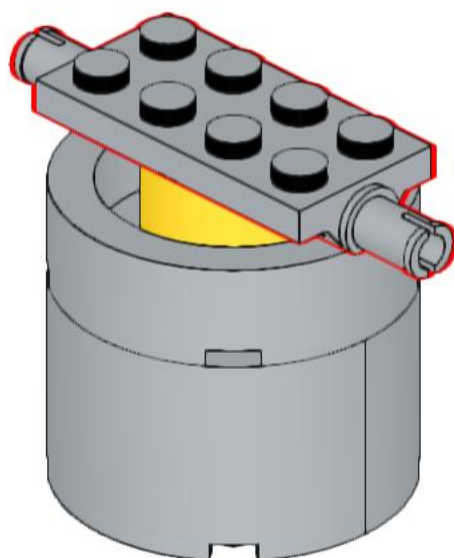
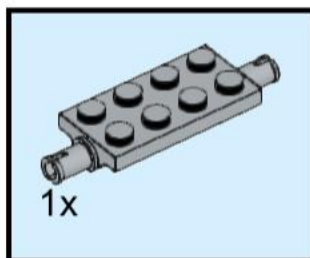

116

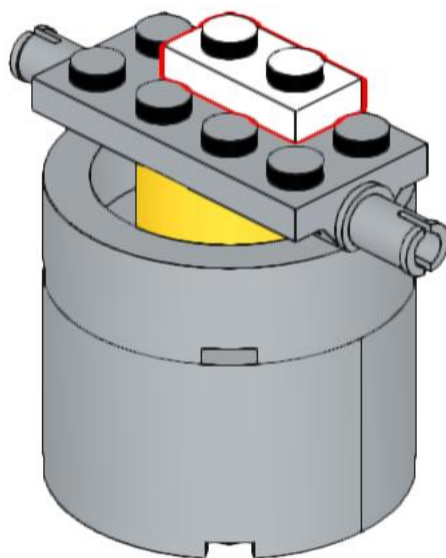
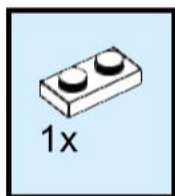

117

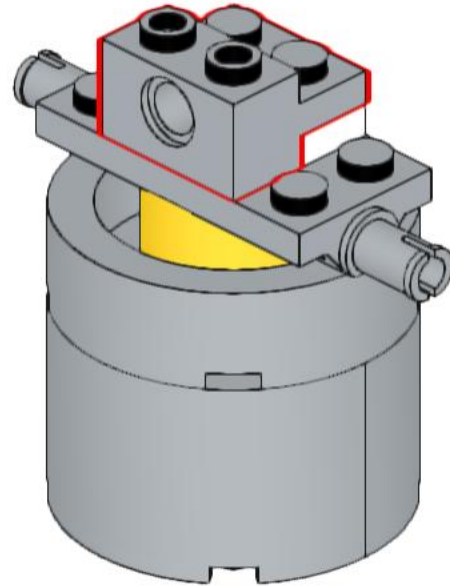
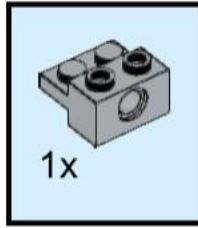

118

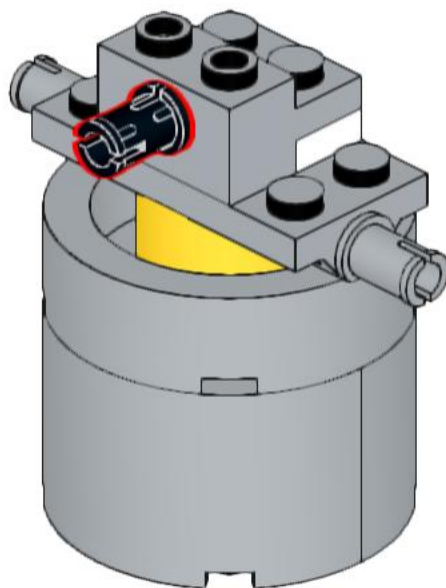

119

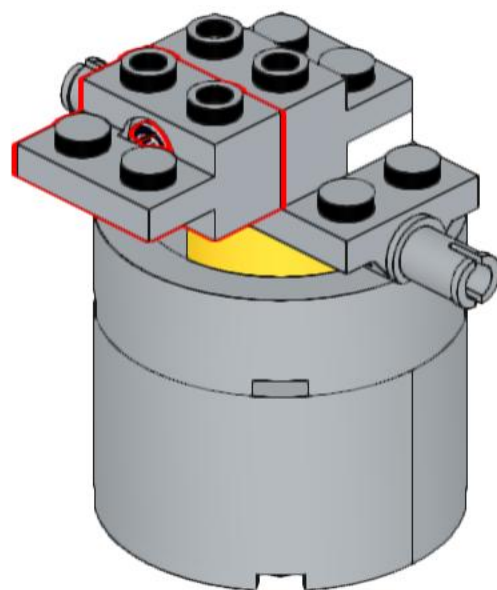
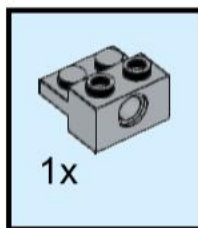

120

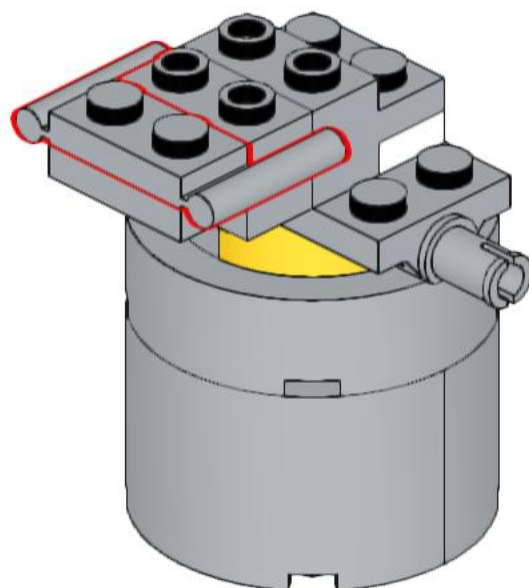
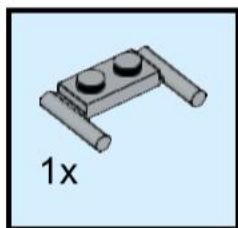

121

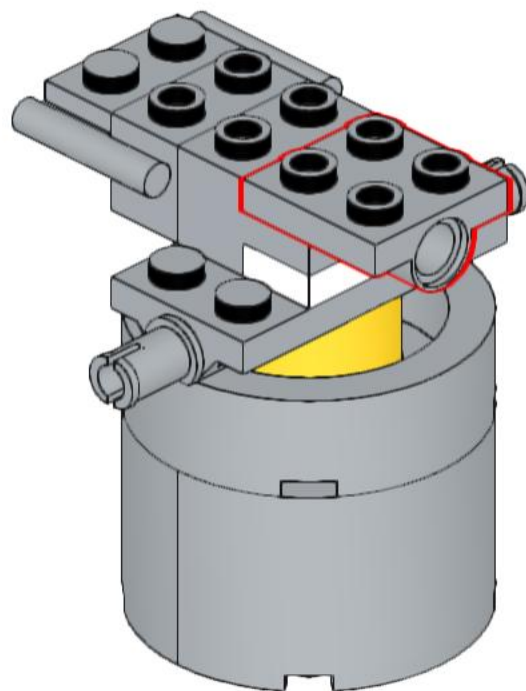
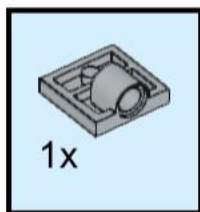

123

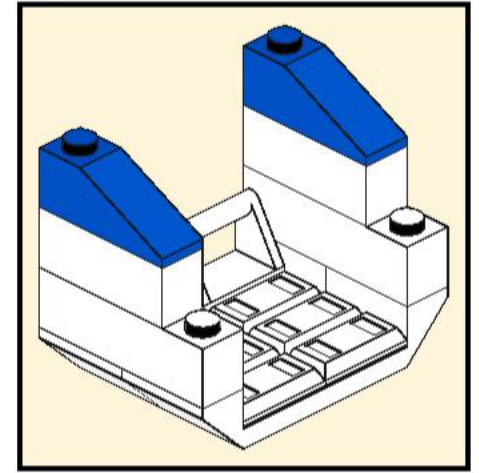
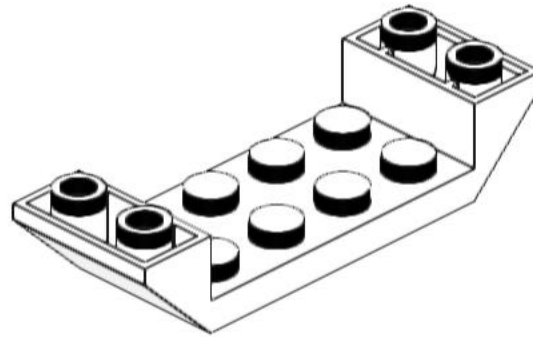
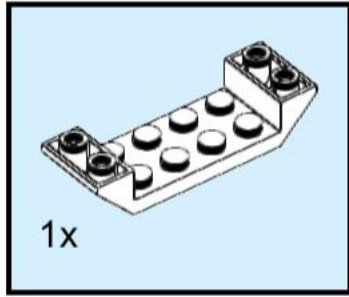

124

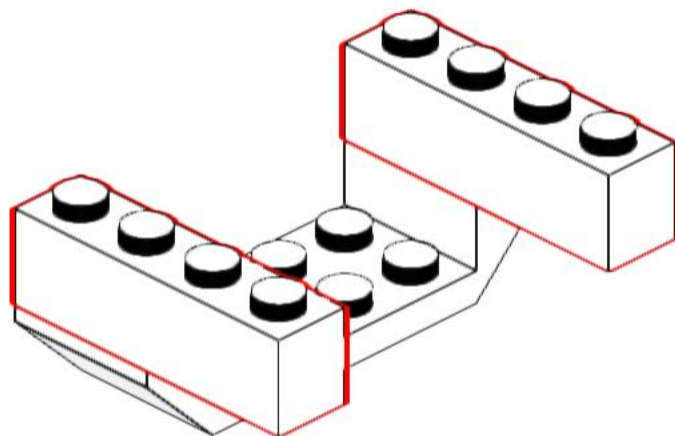
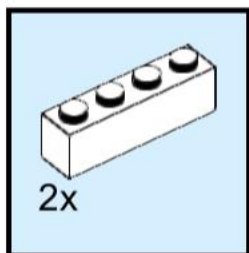

125

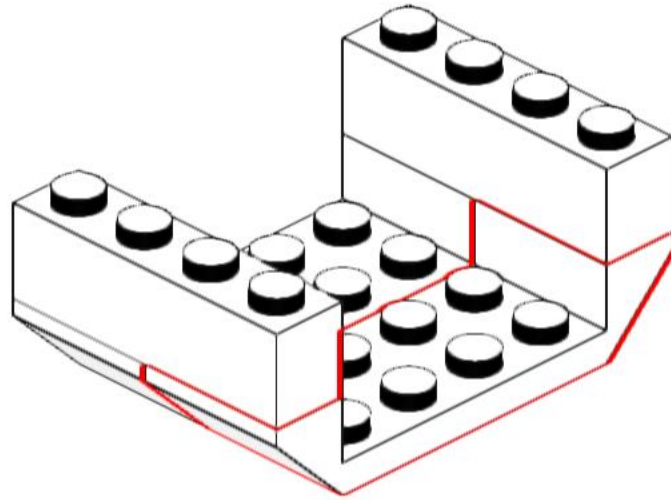
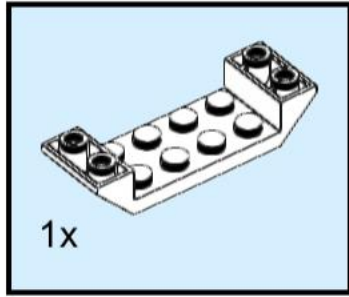

126

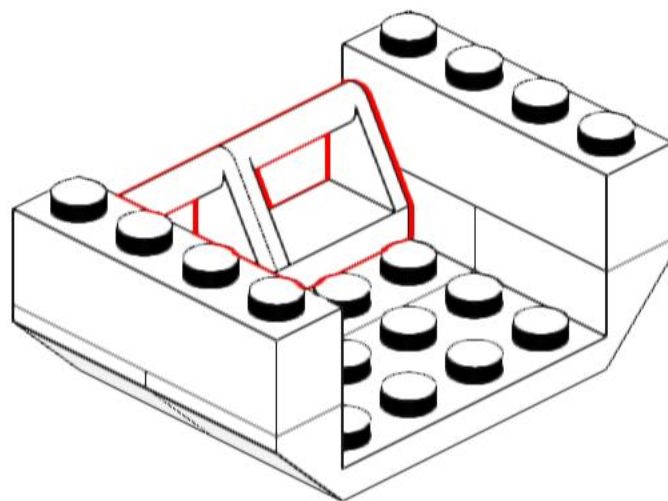
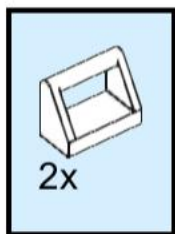

127

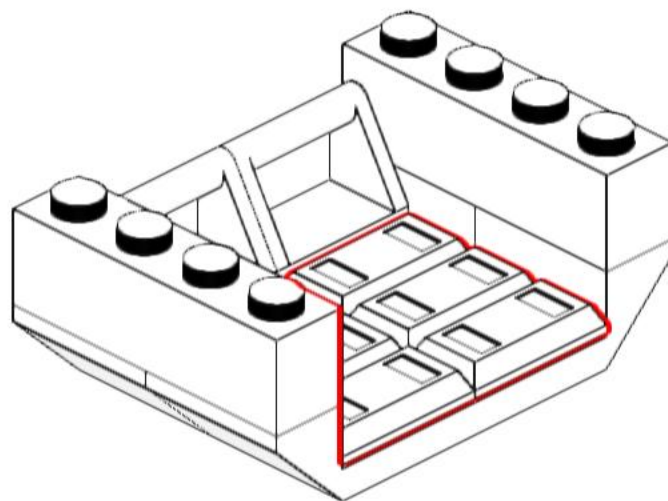
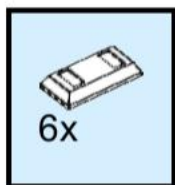

128

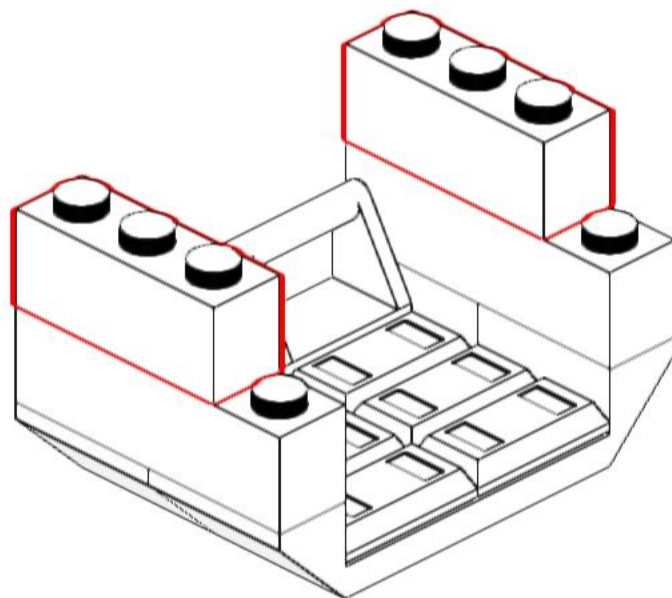
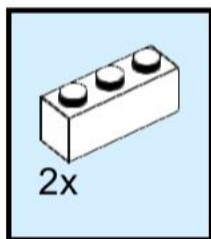

129

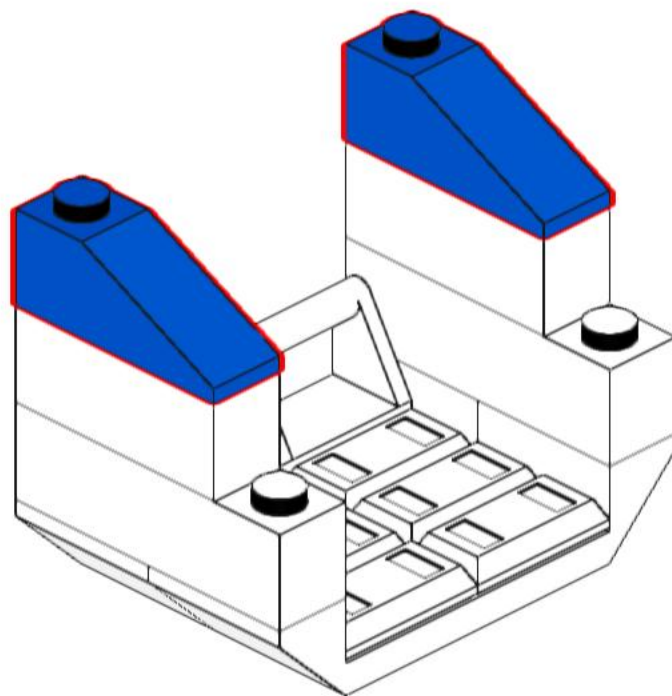
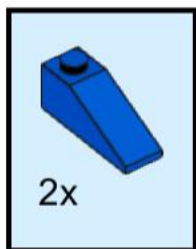

130

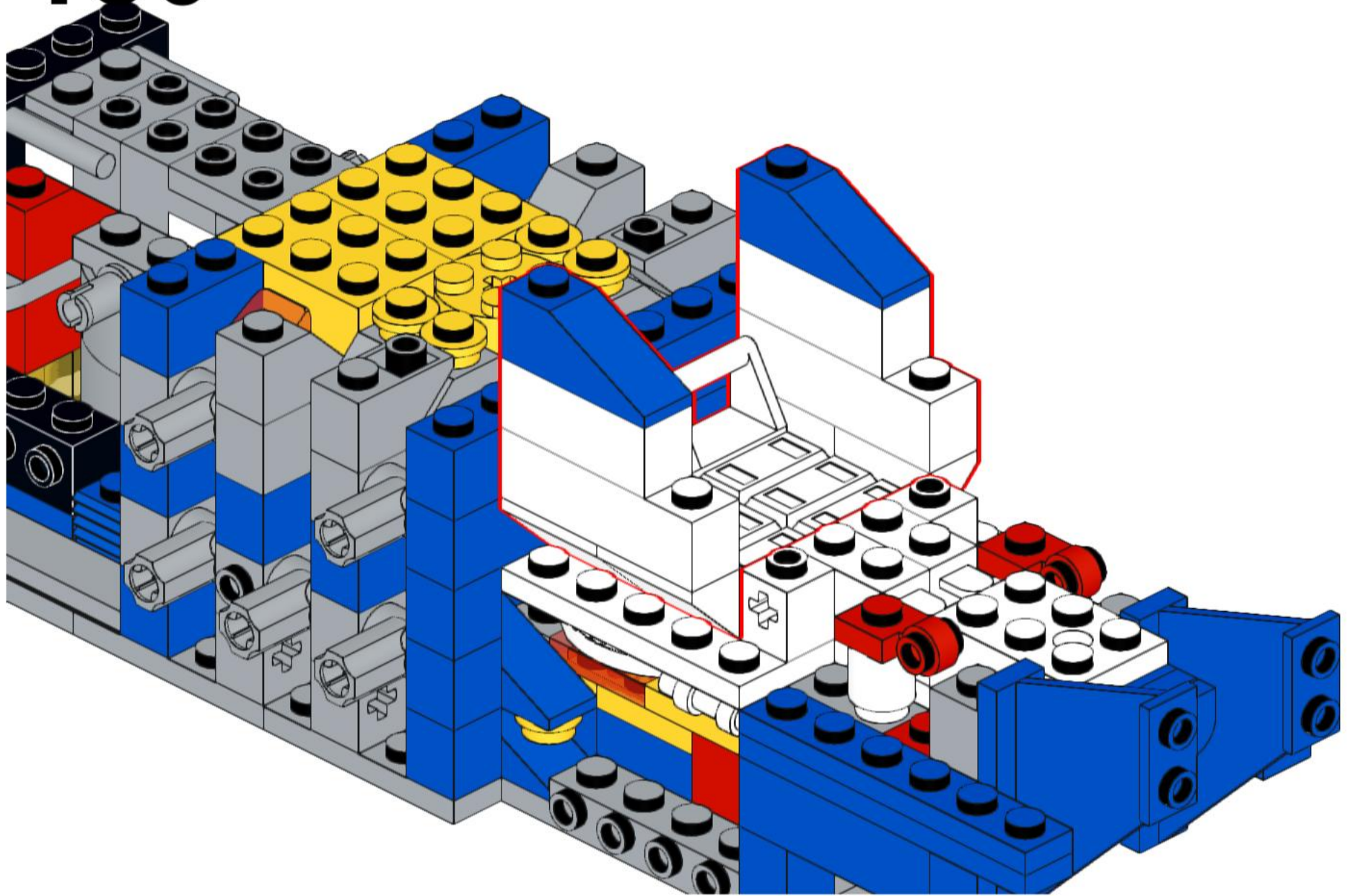

131

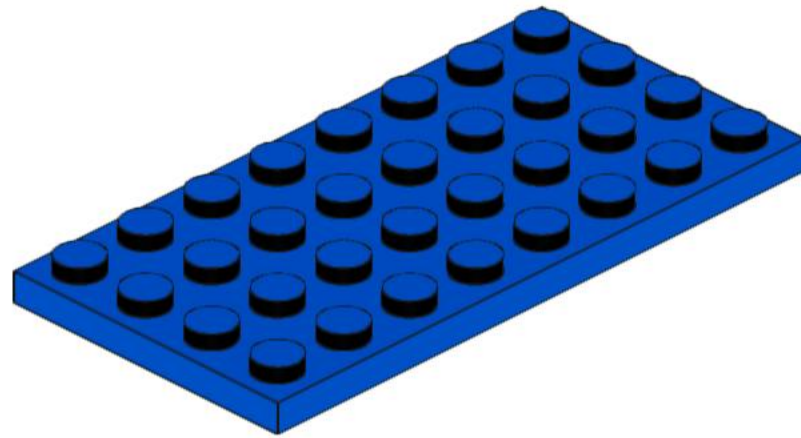
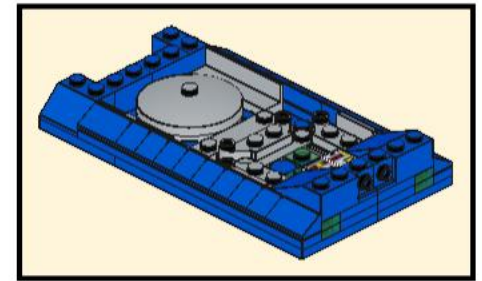
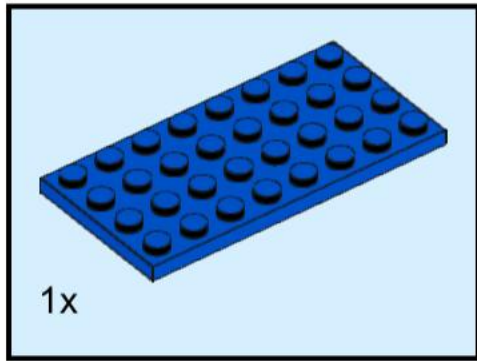

132

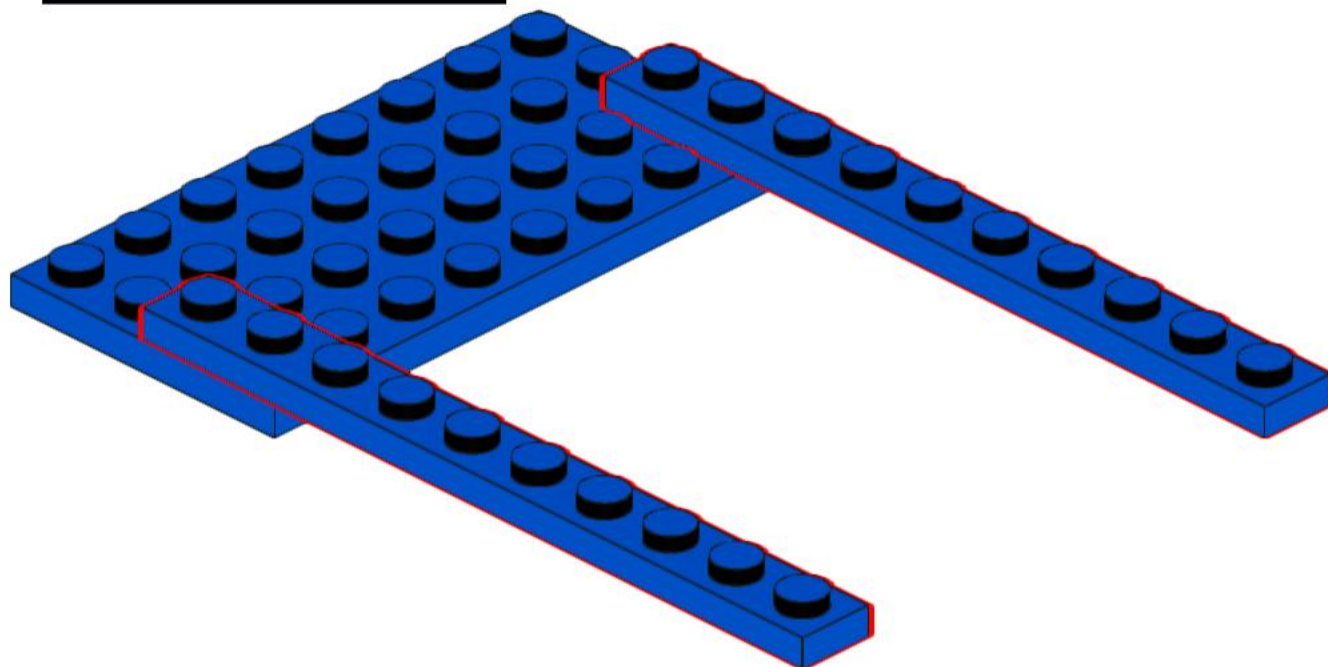
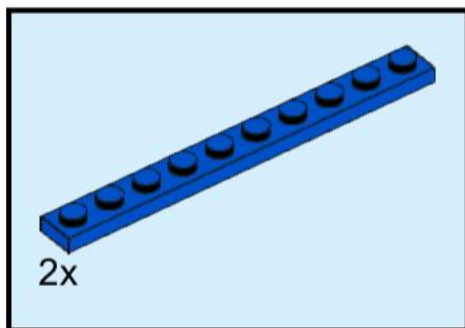

133

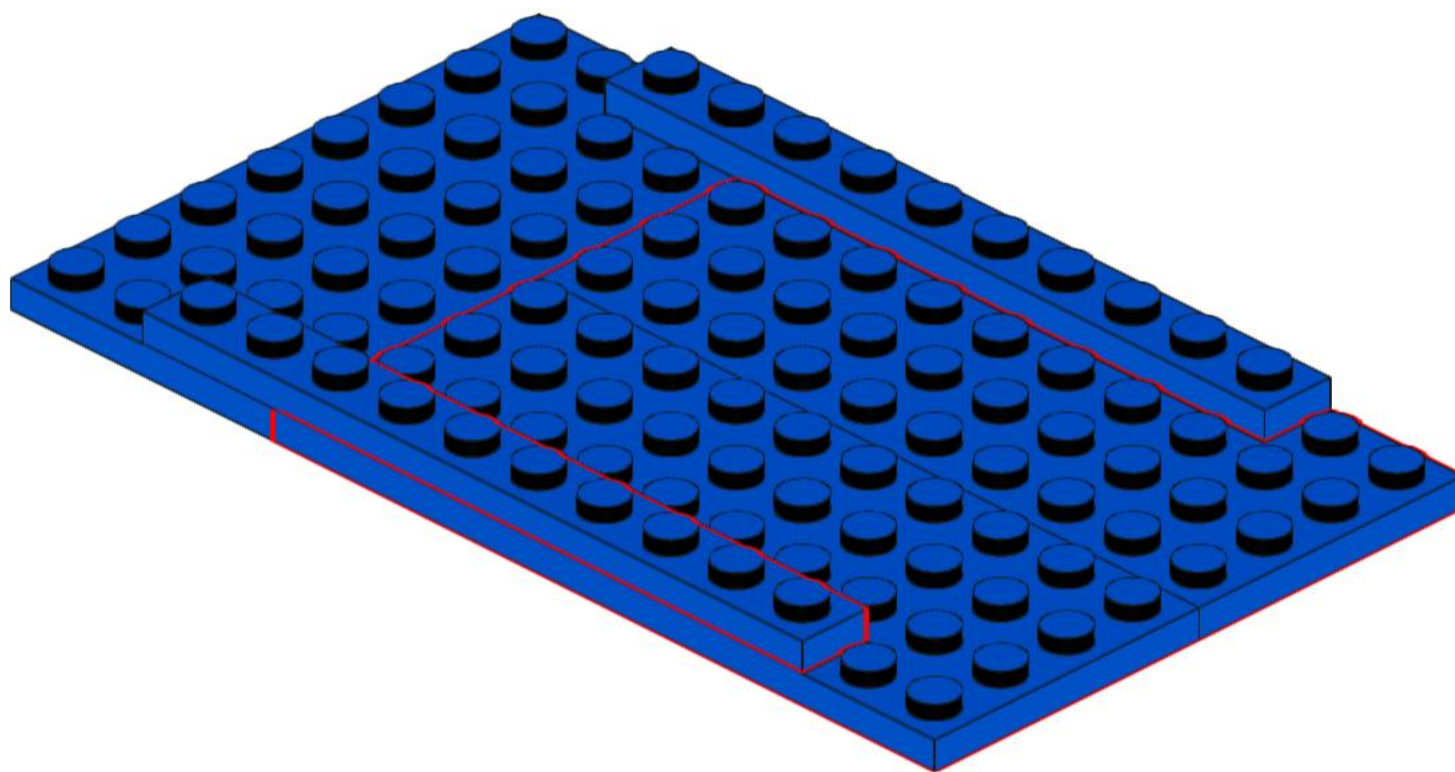
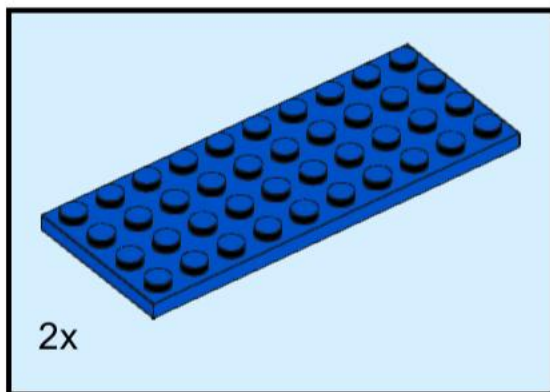

134

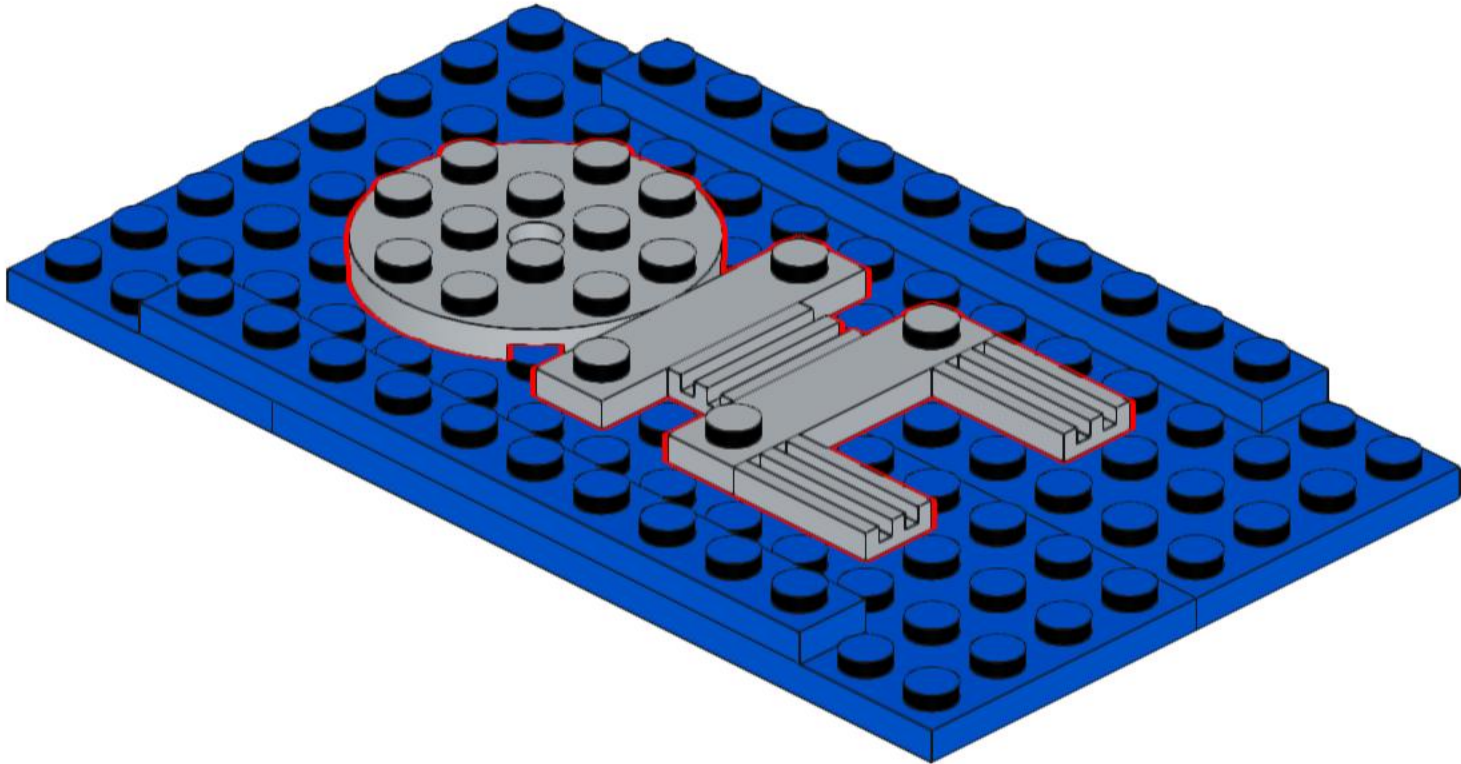
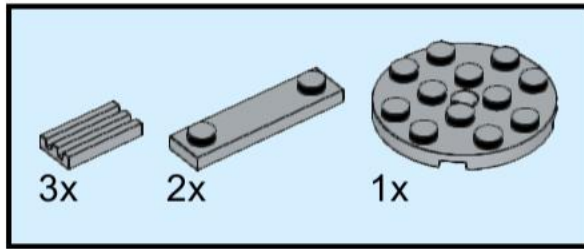

135

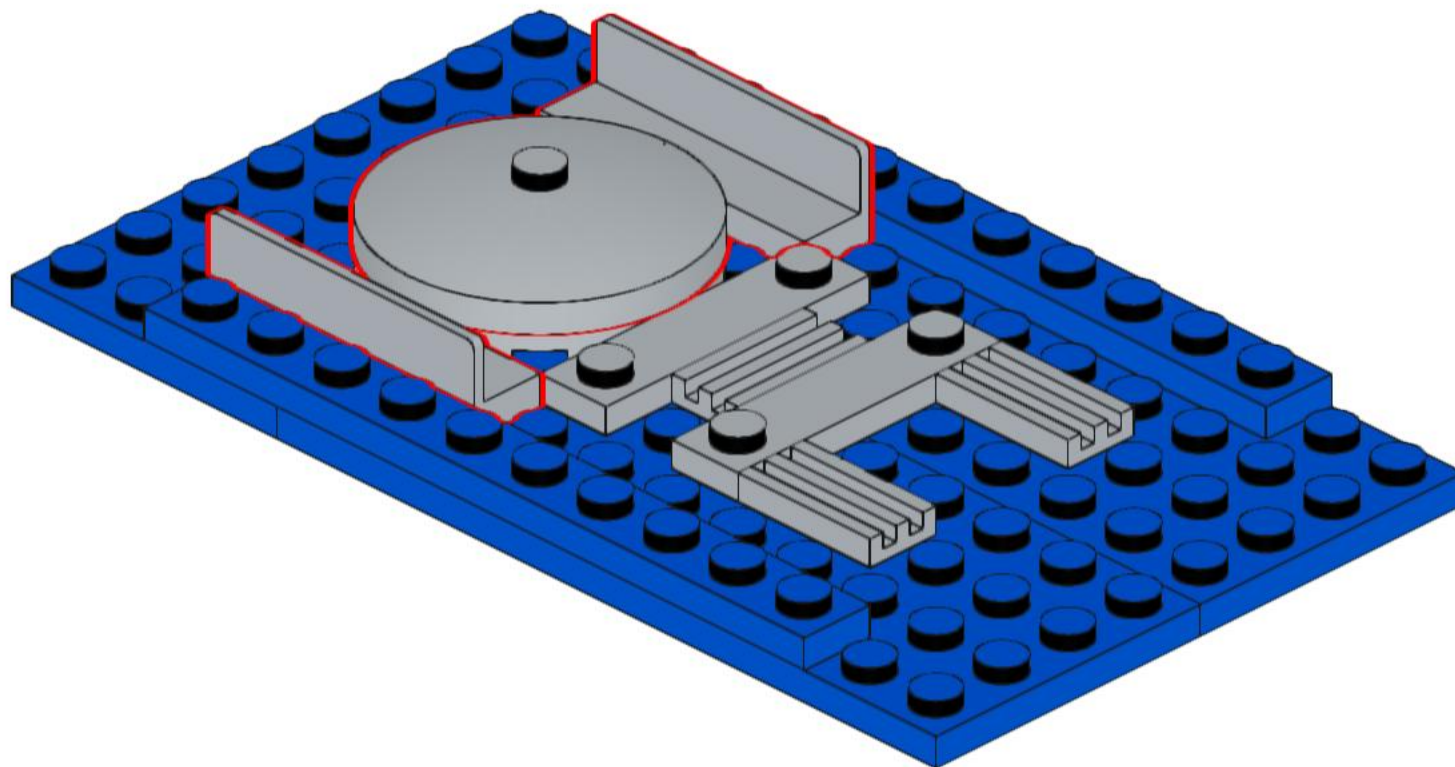
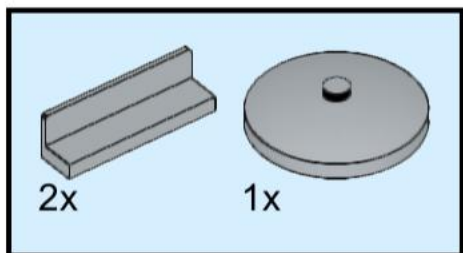

136

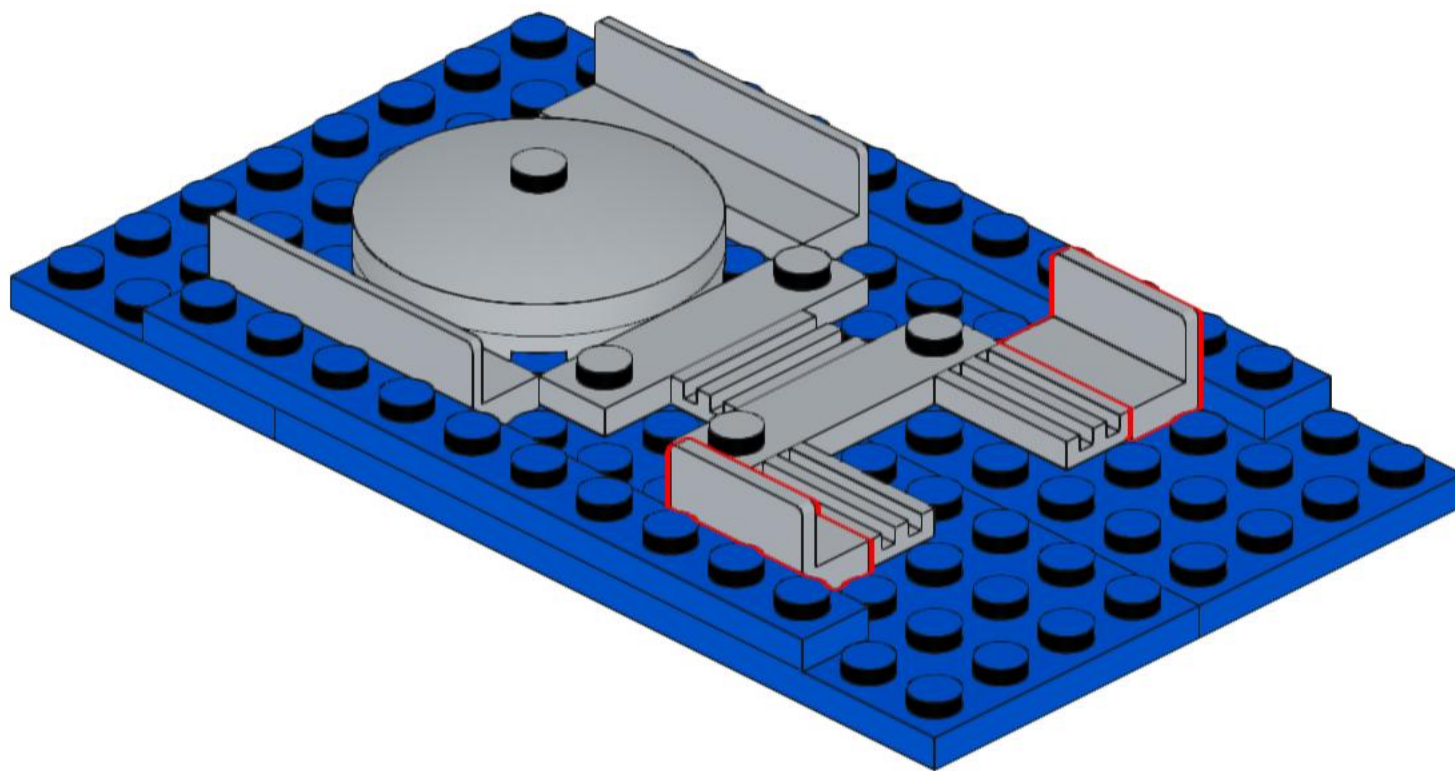
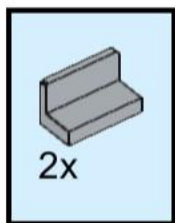

137

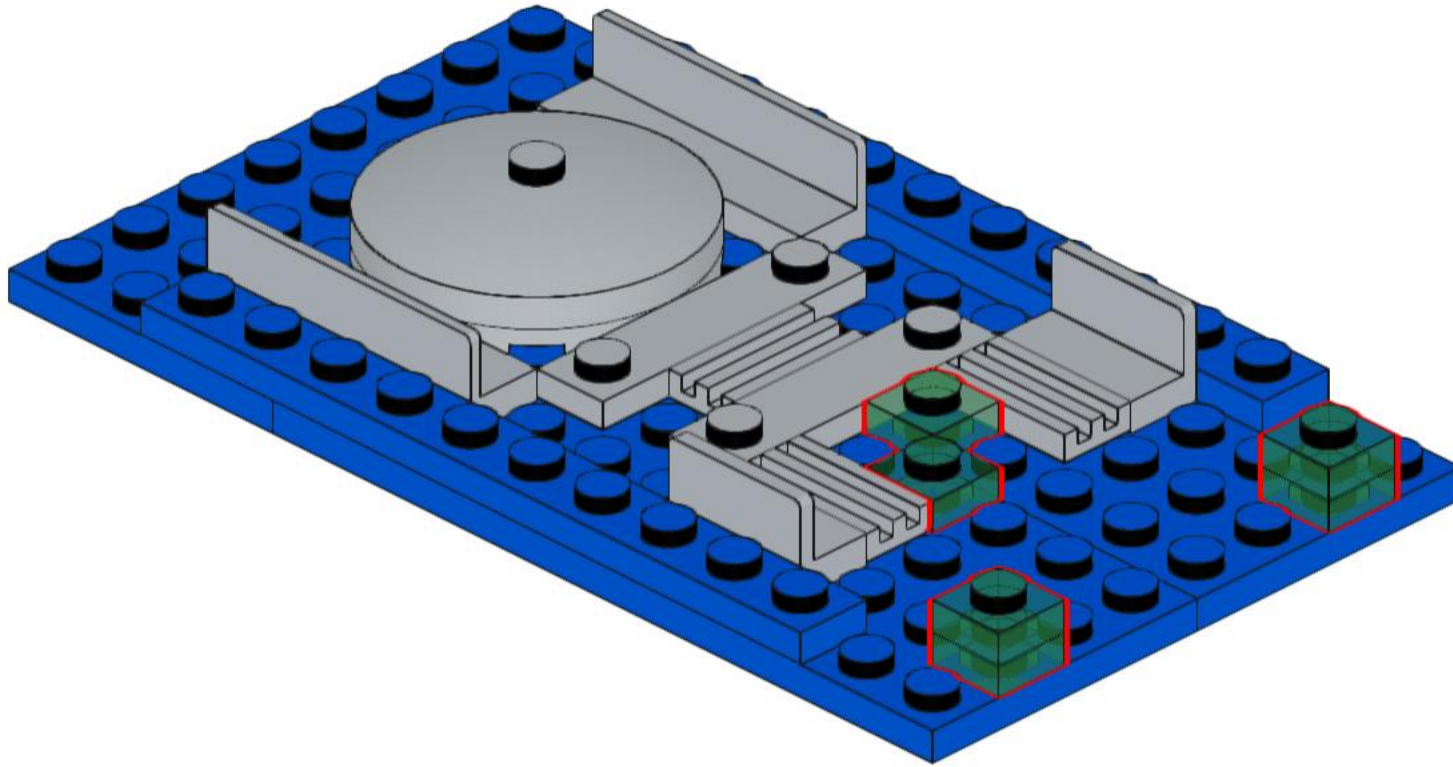
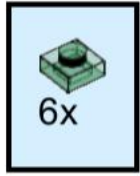

138

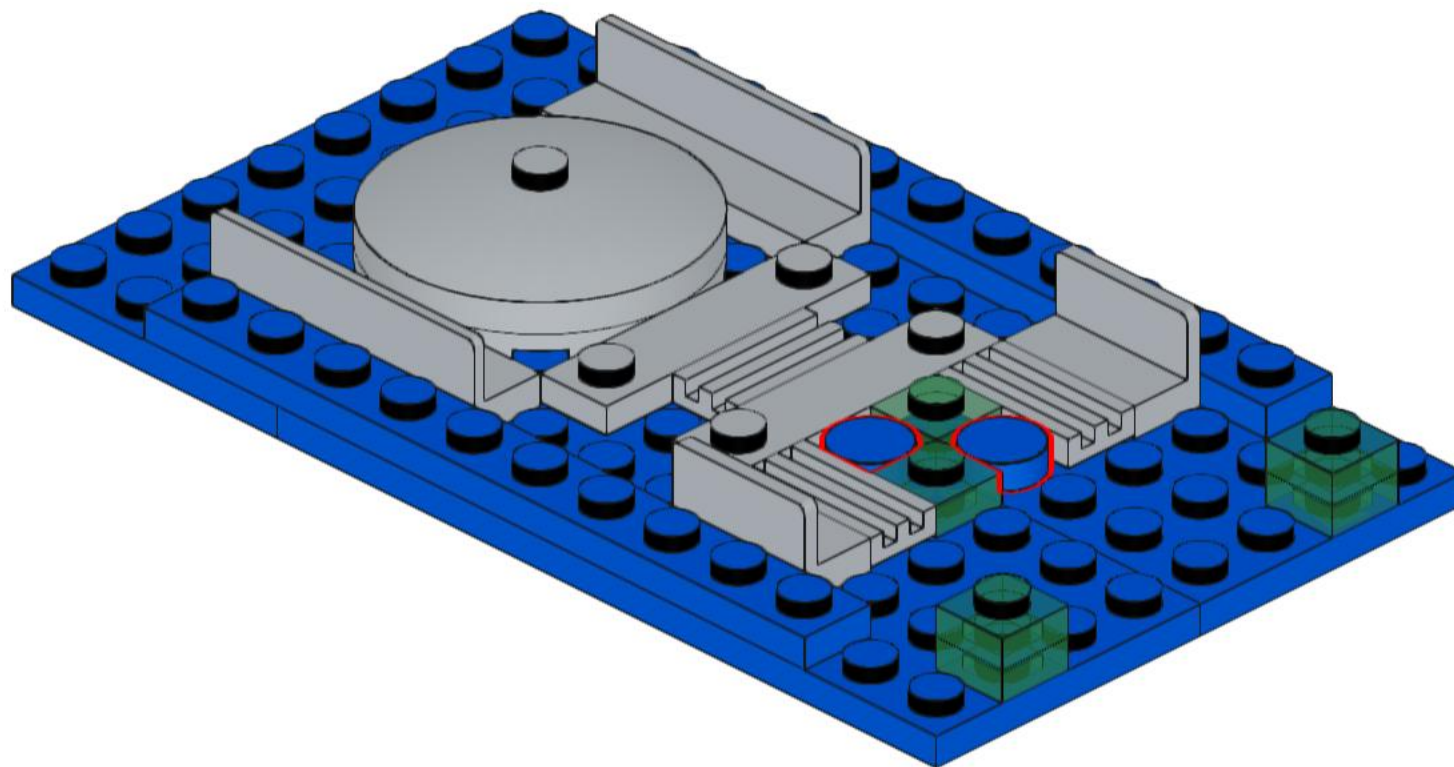
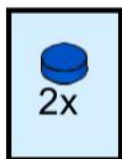

139

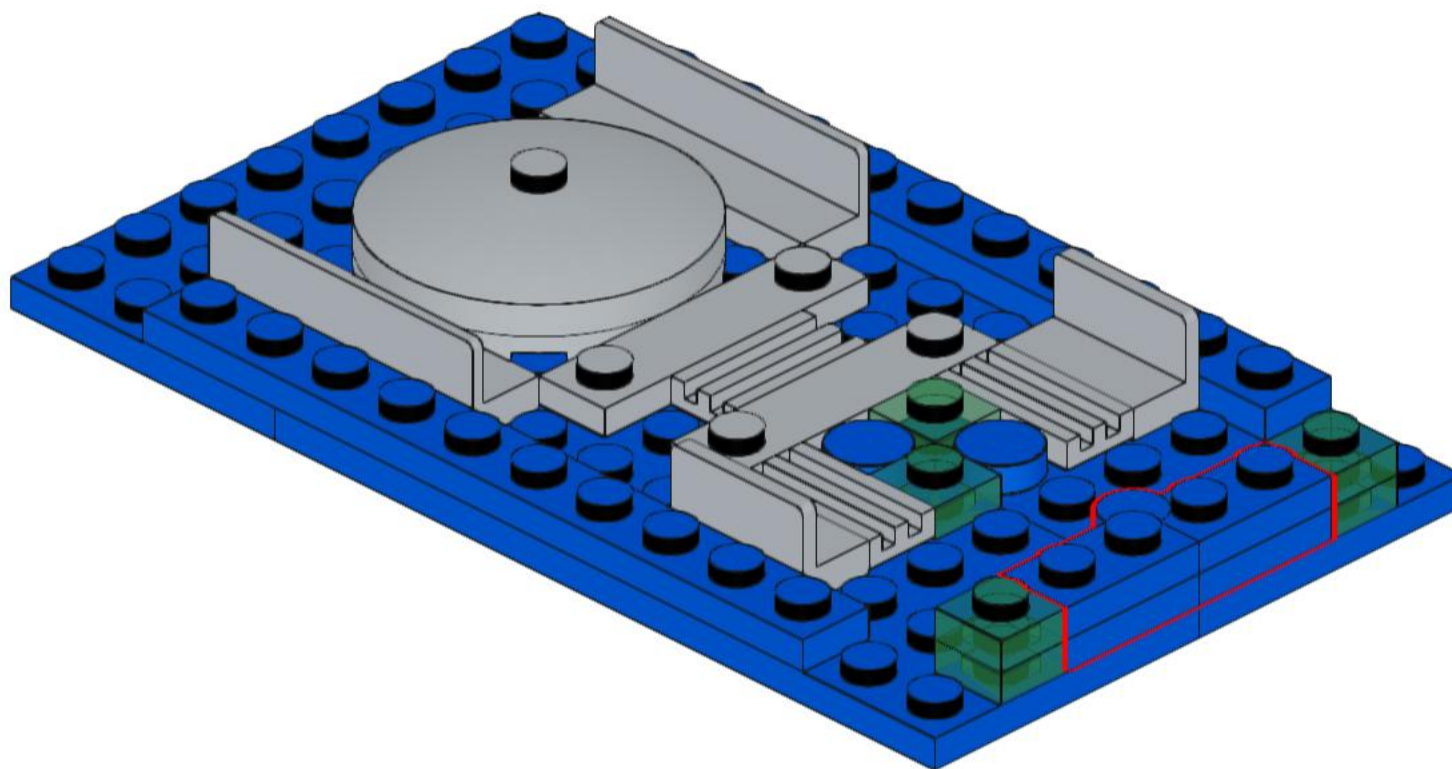
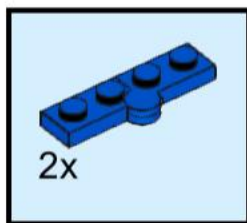

140

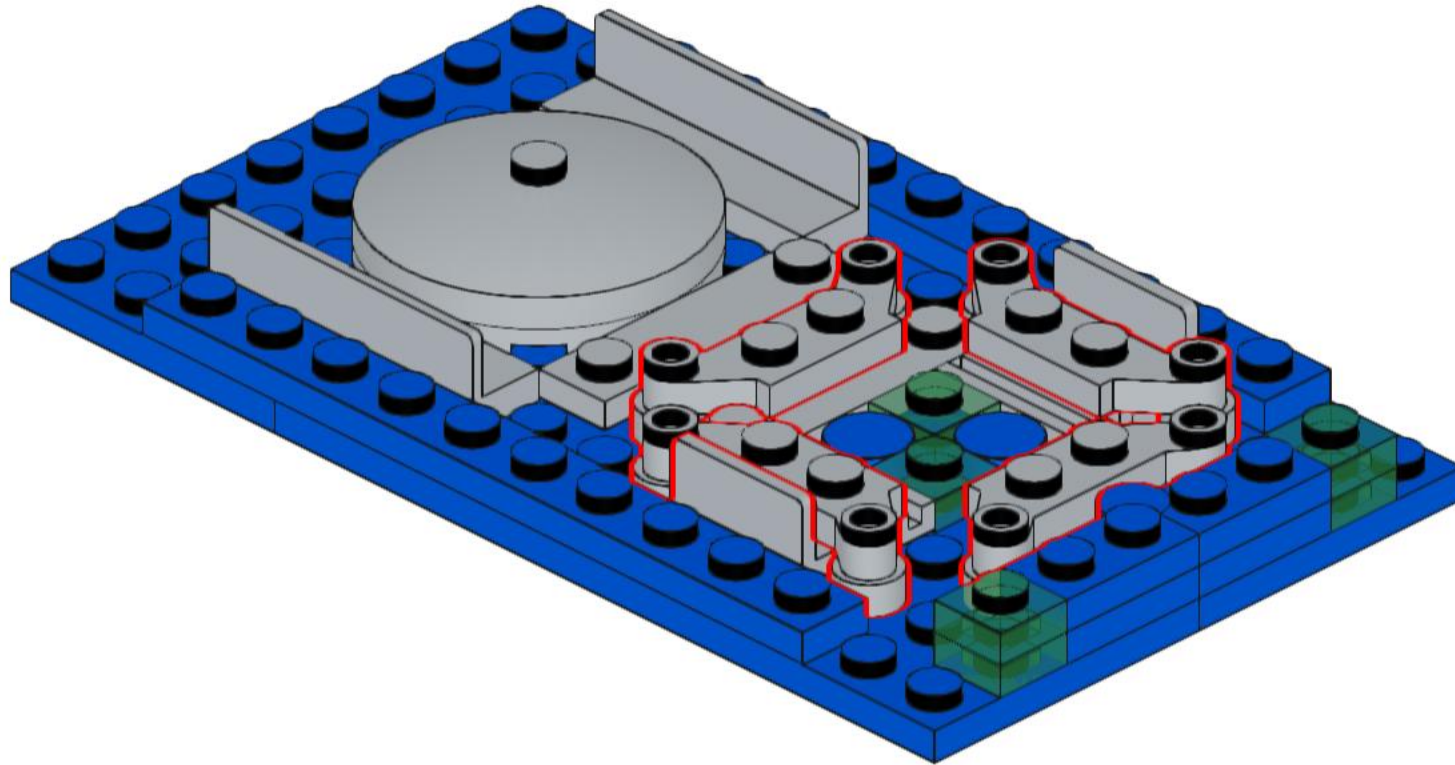
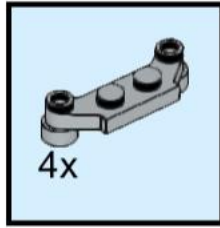

141

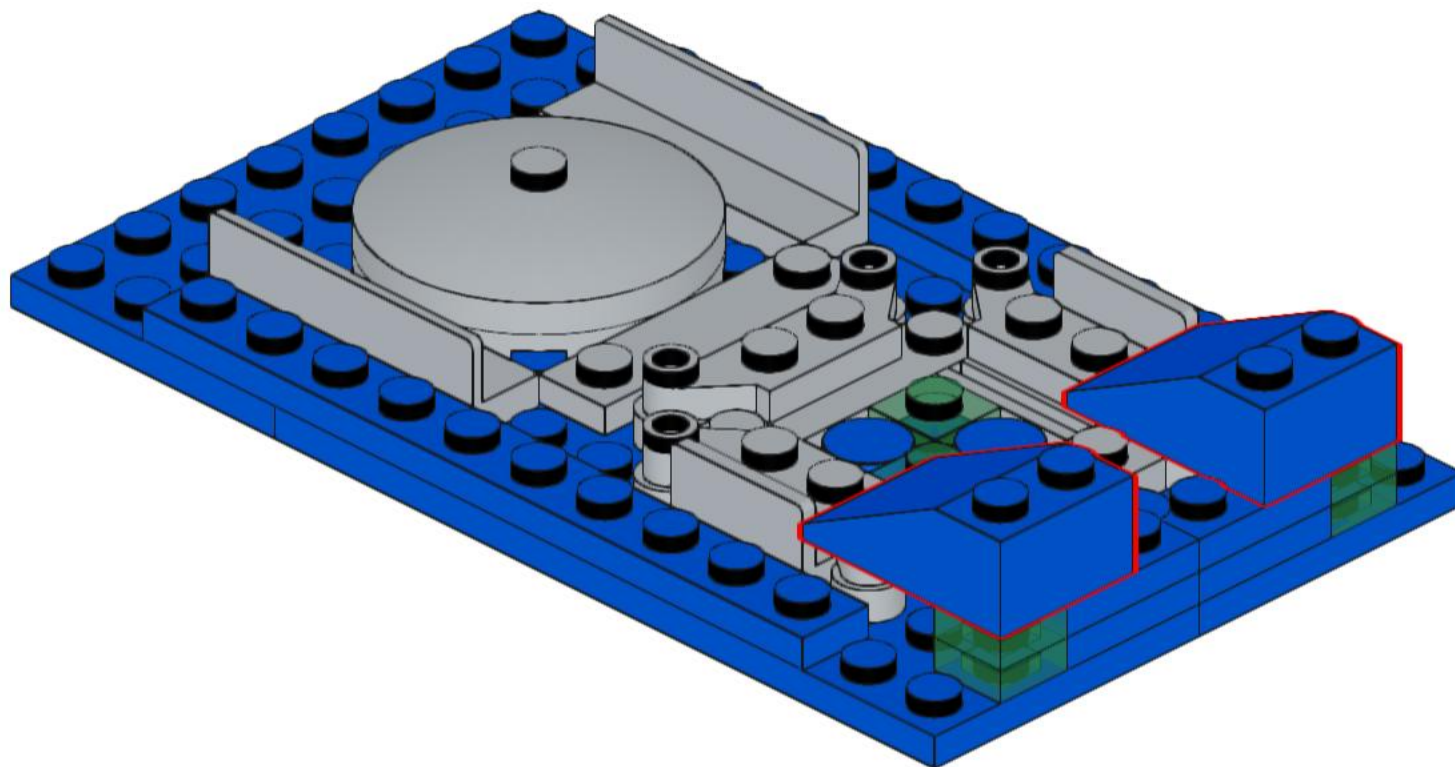
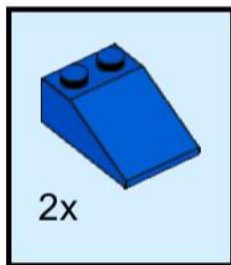

142

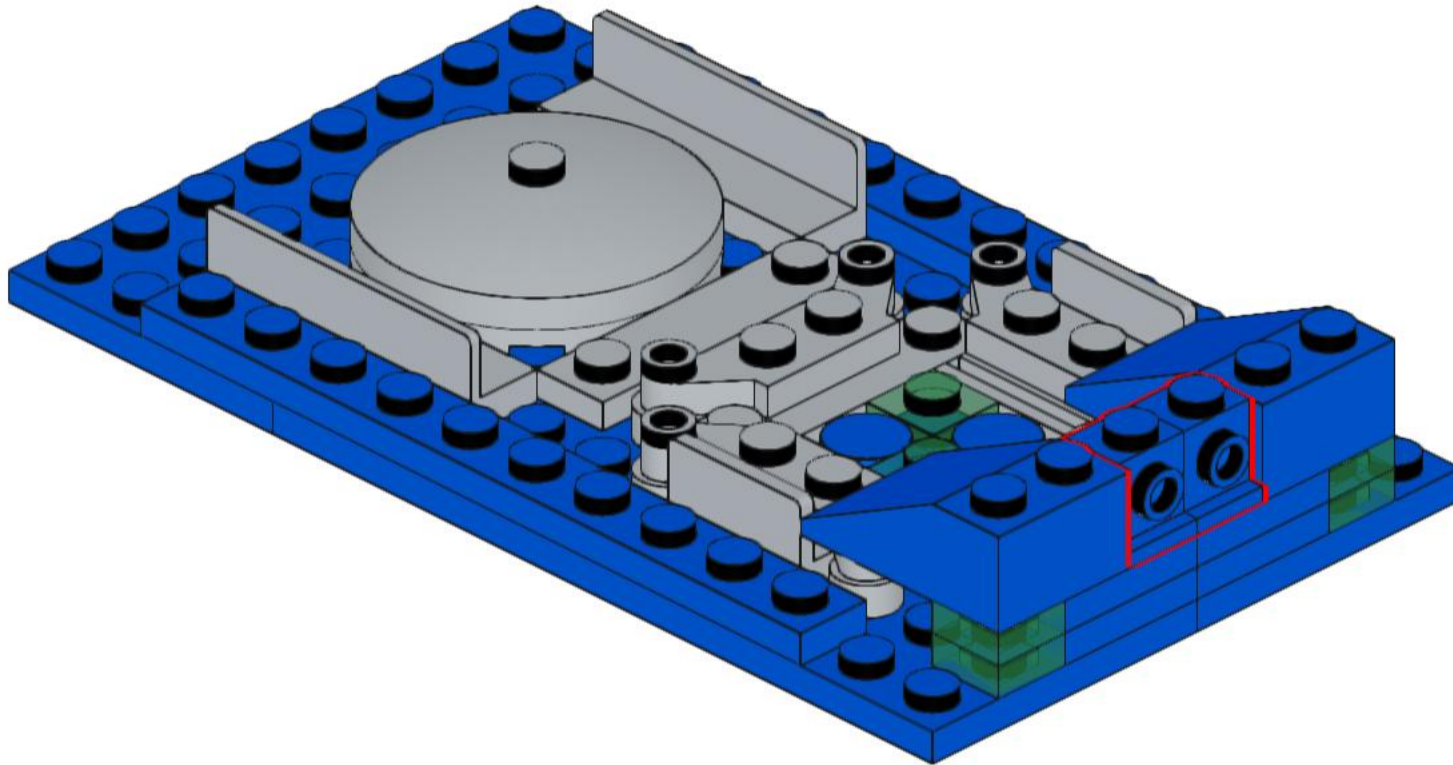

143

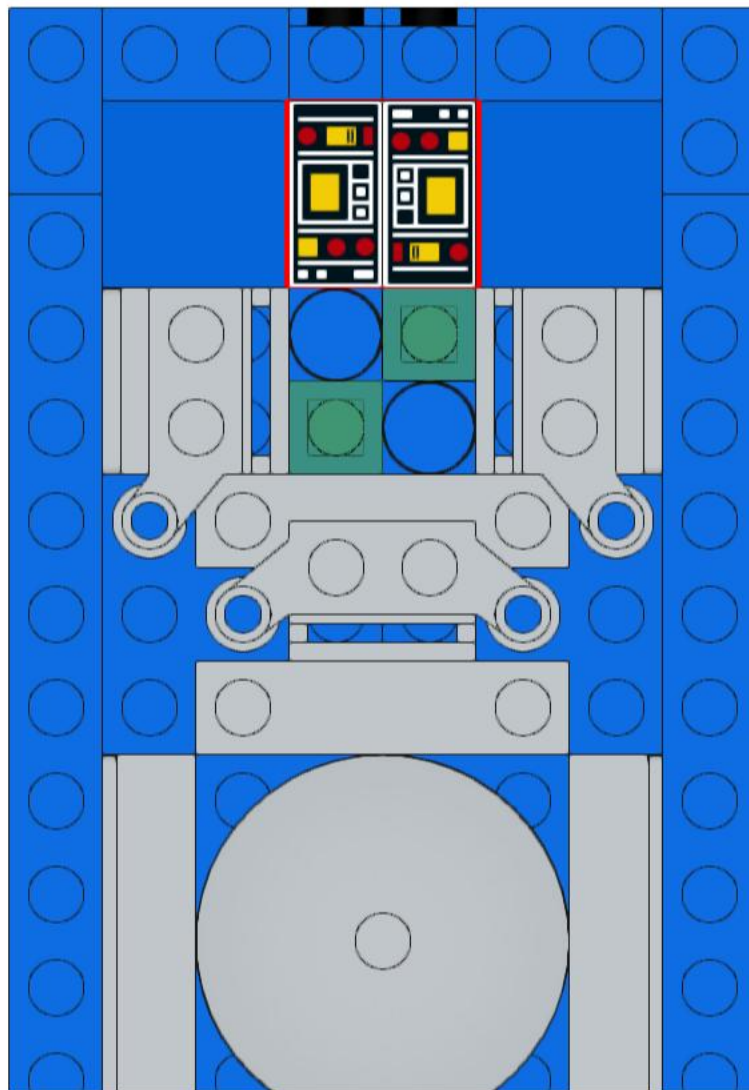
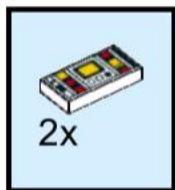

144

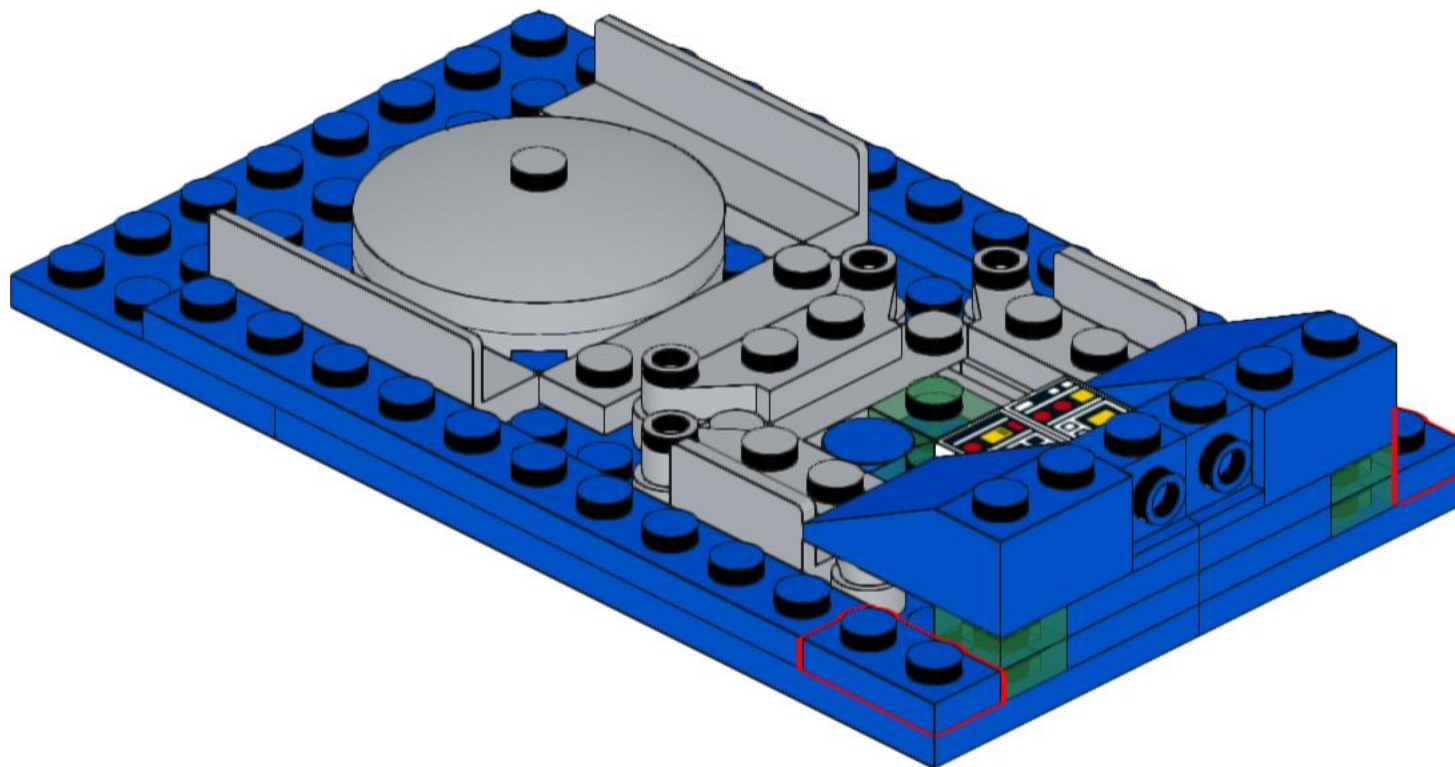
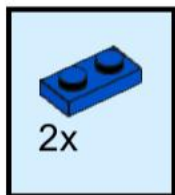

145

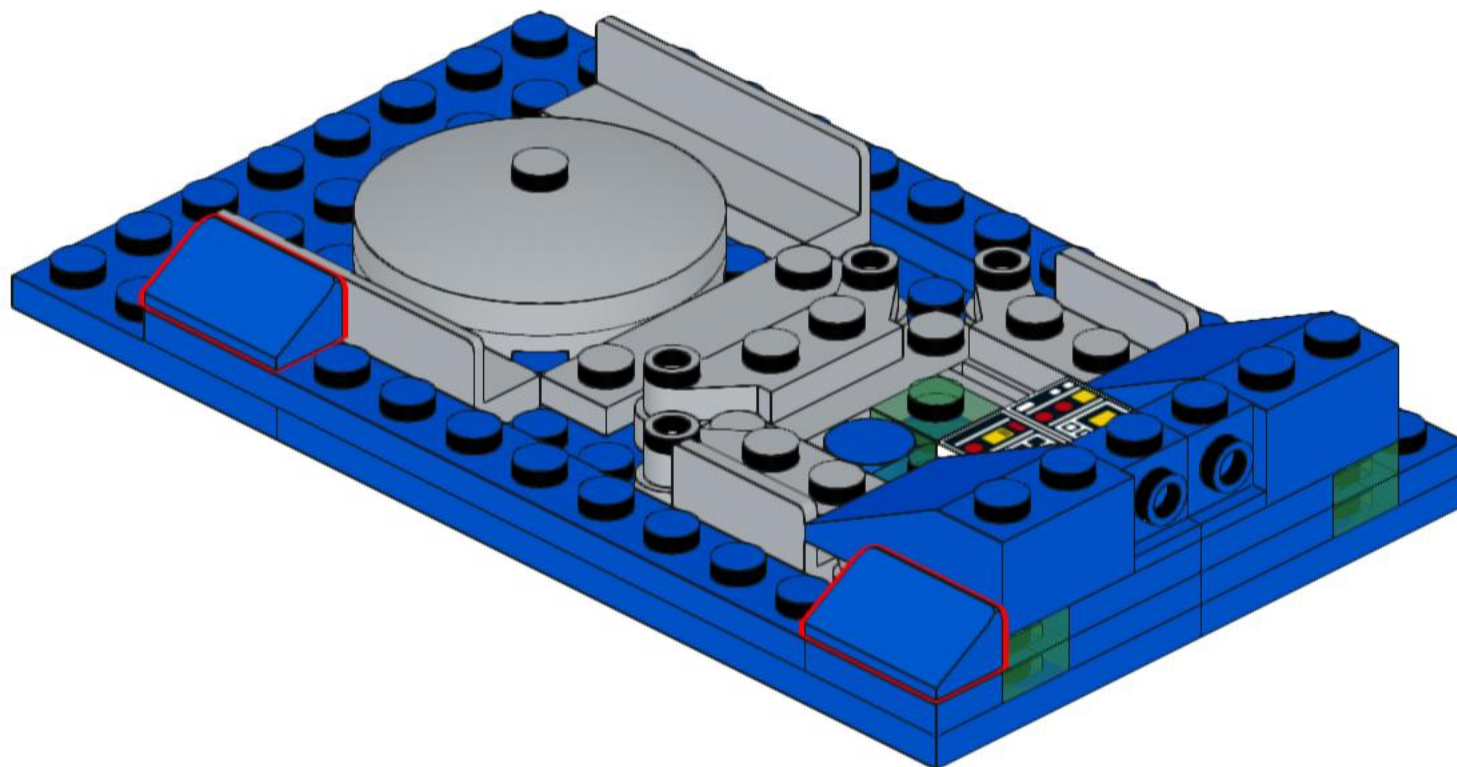
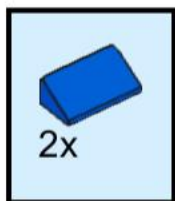

146

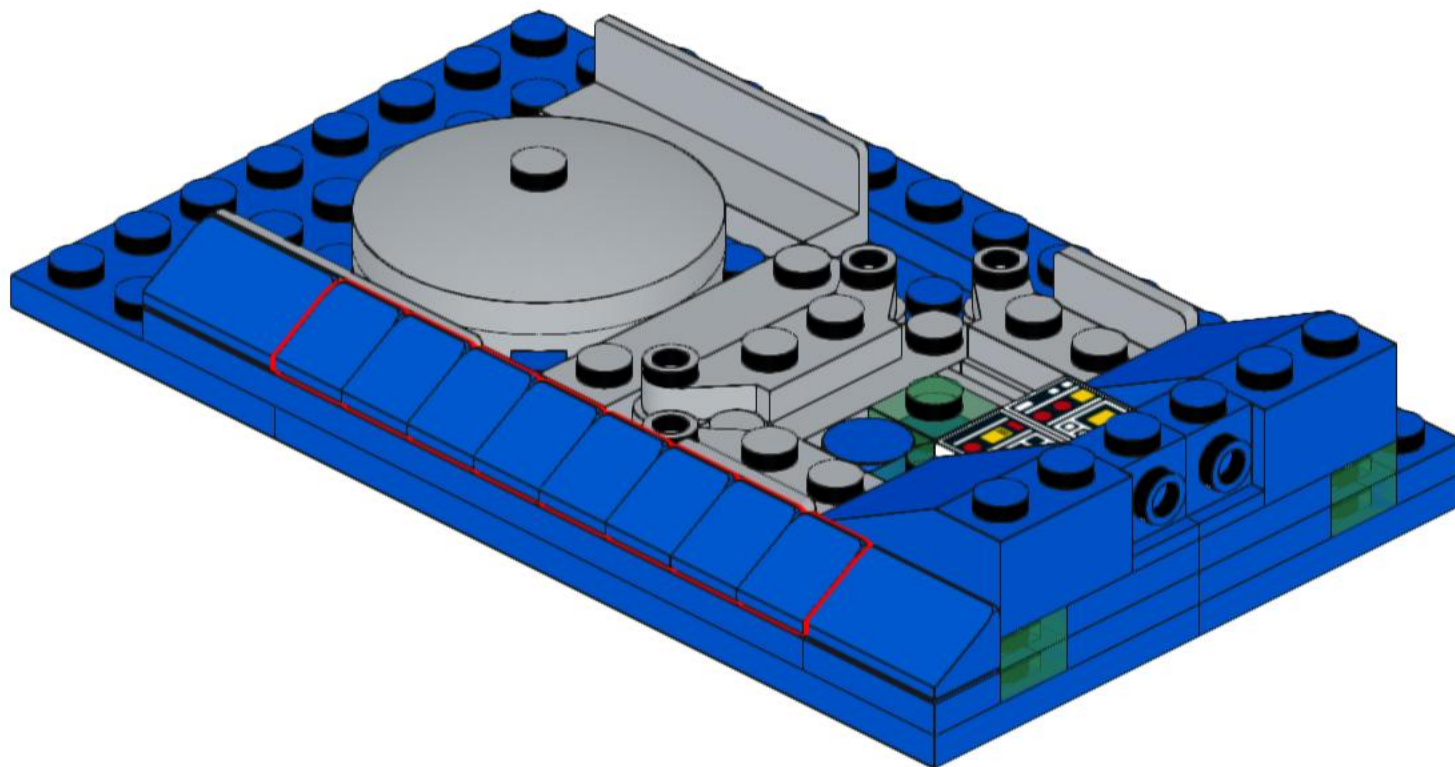
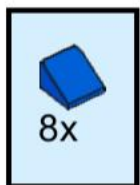

147

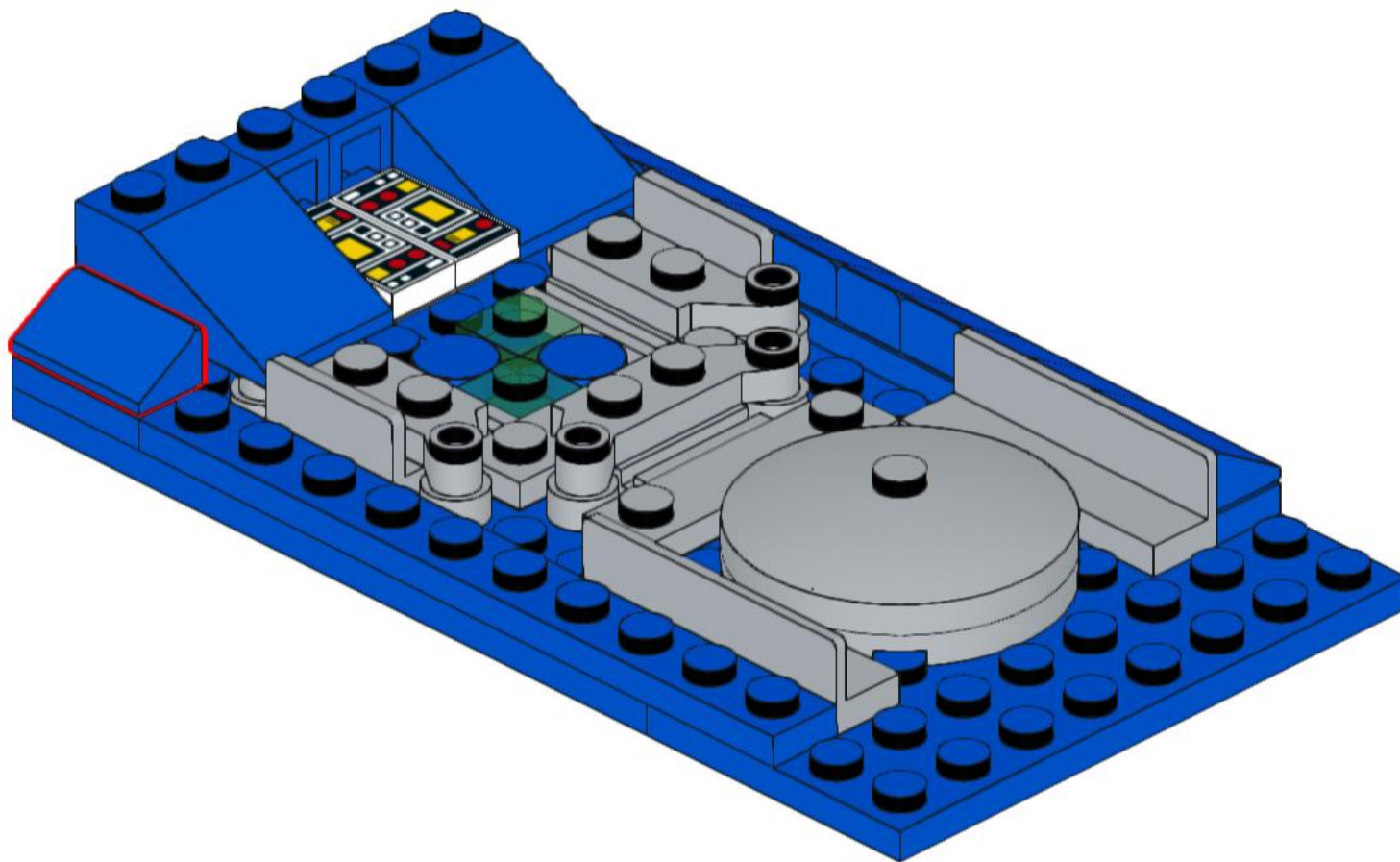
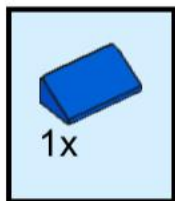

148

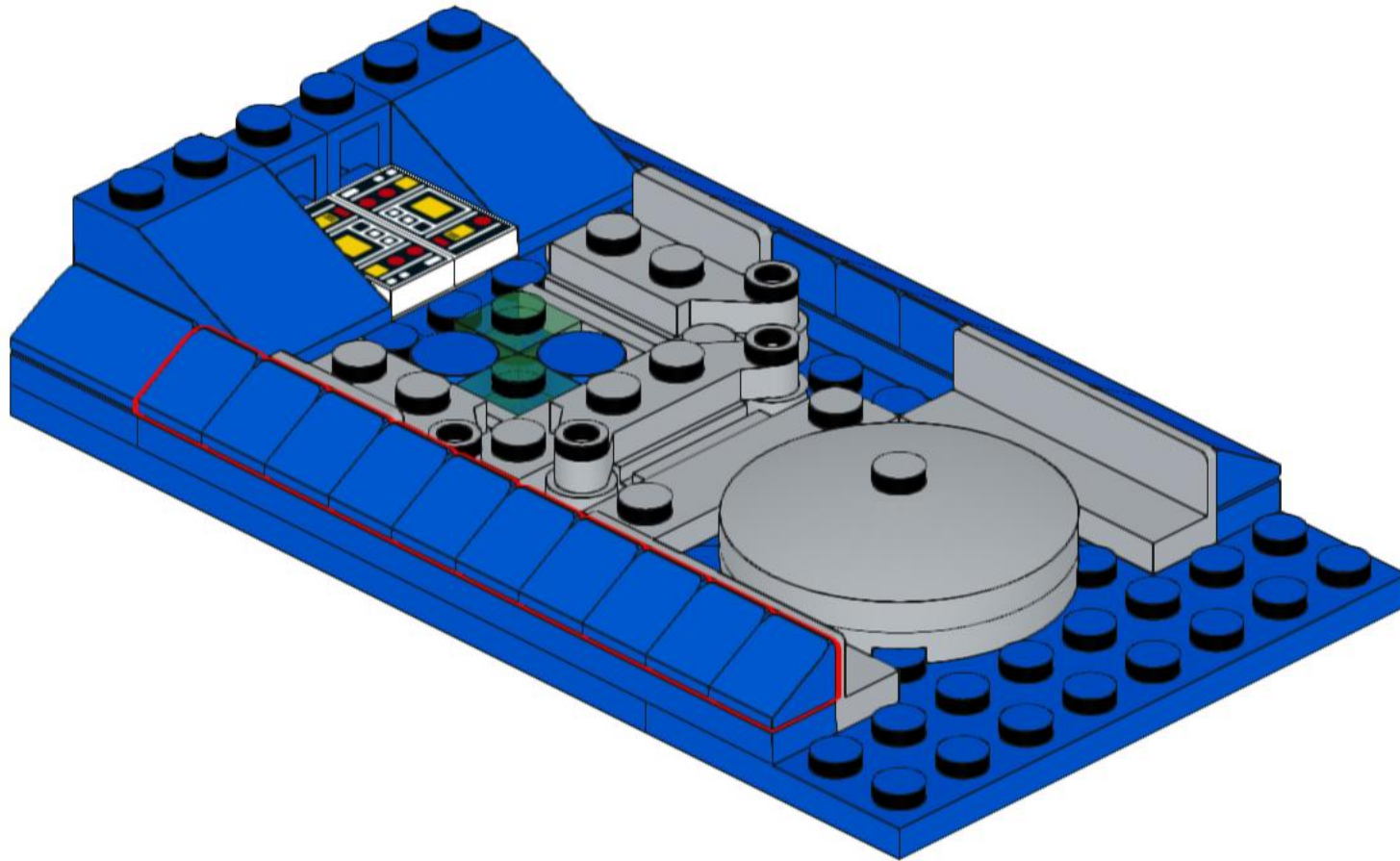
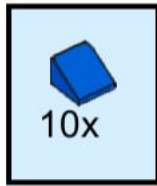

149

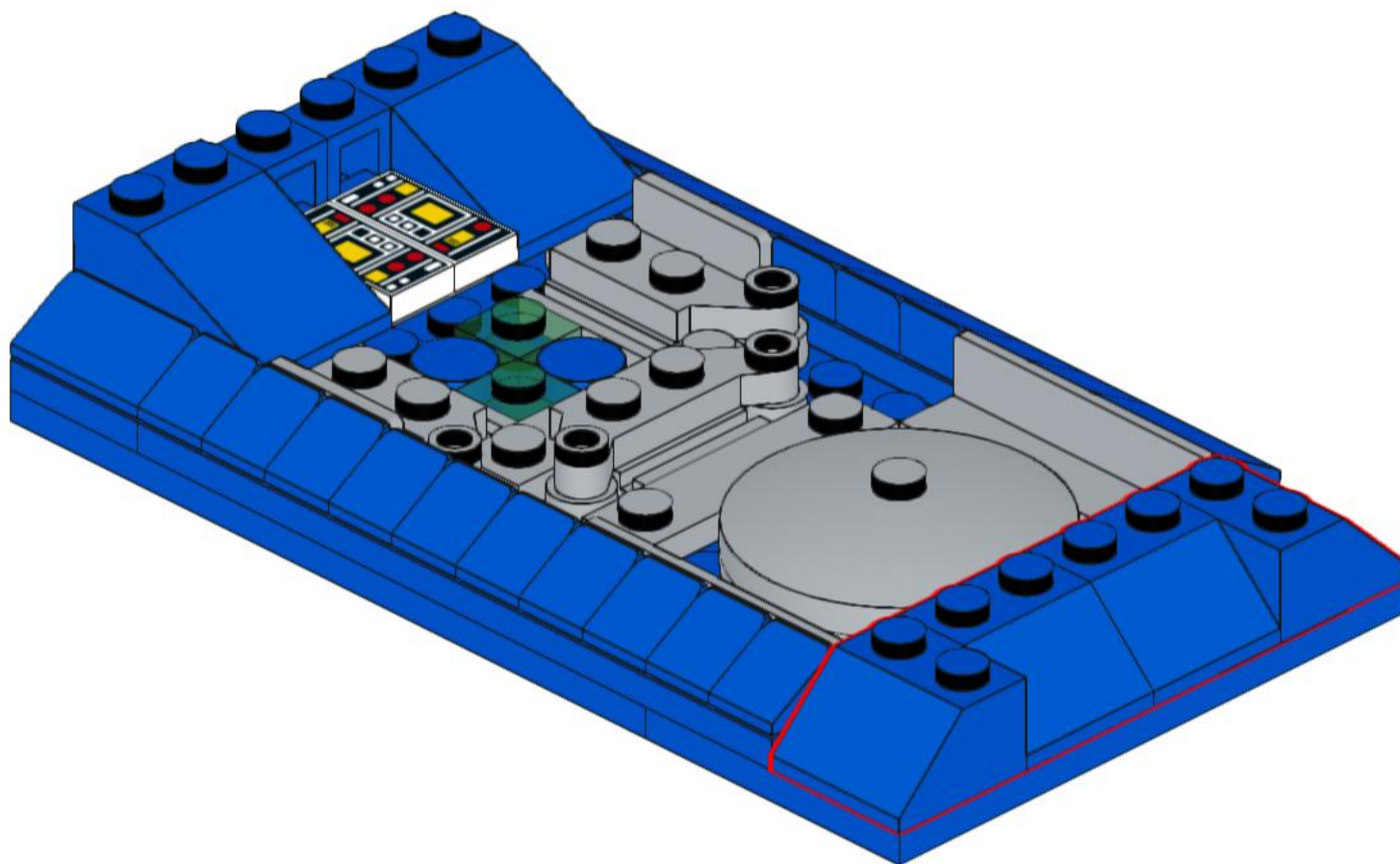
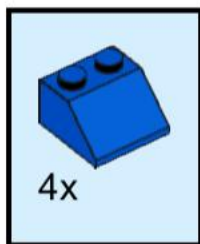

150

This can be difficult because of all the studs connecting at the same time. Make sure to apply a decent amount of pressure until this "roof" section is sitting flush.

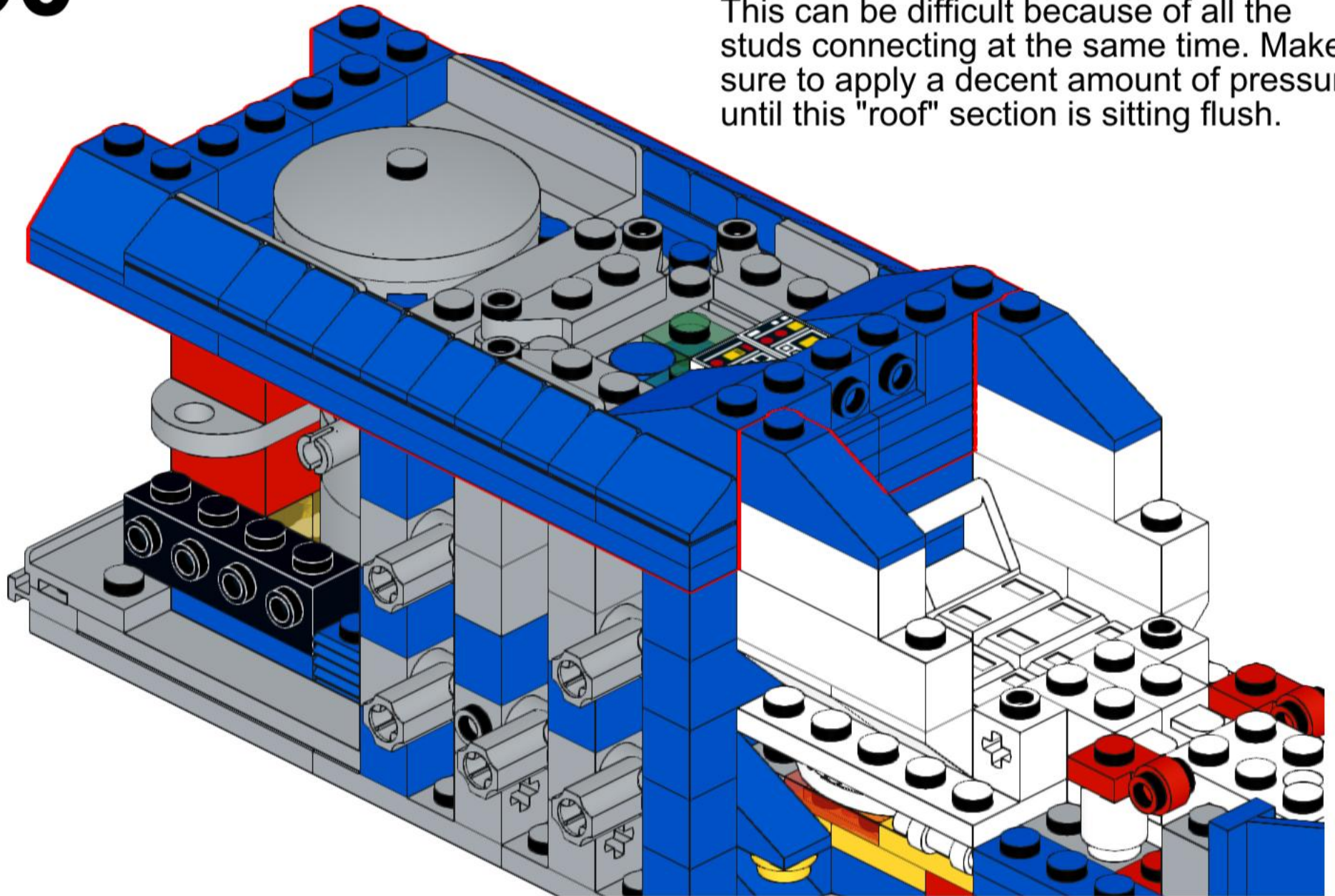

151

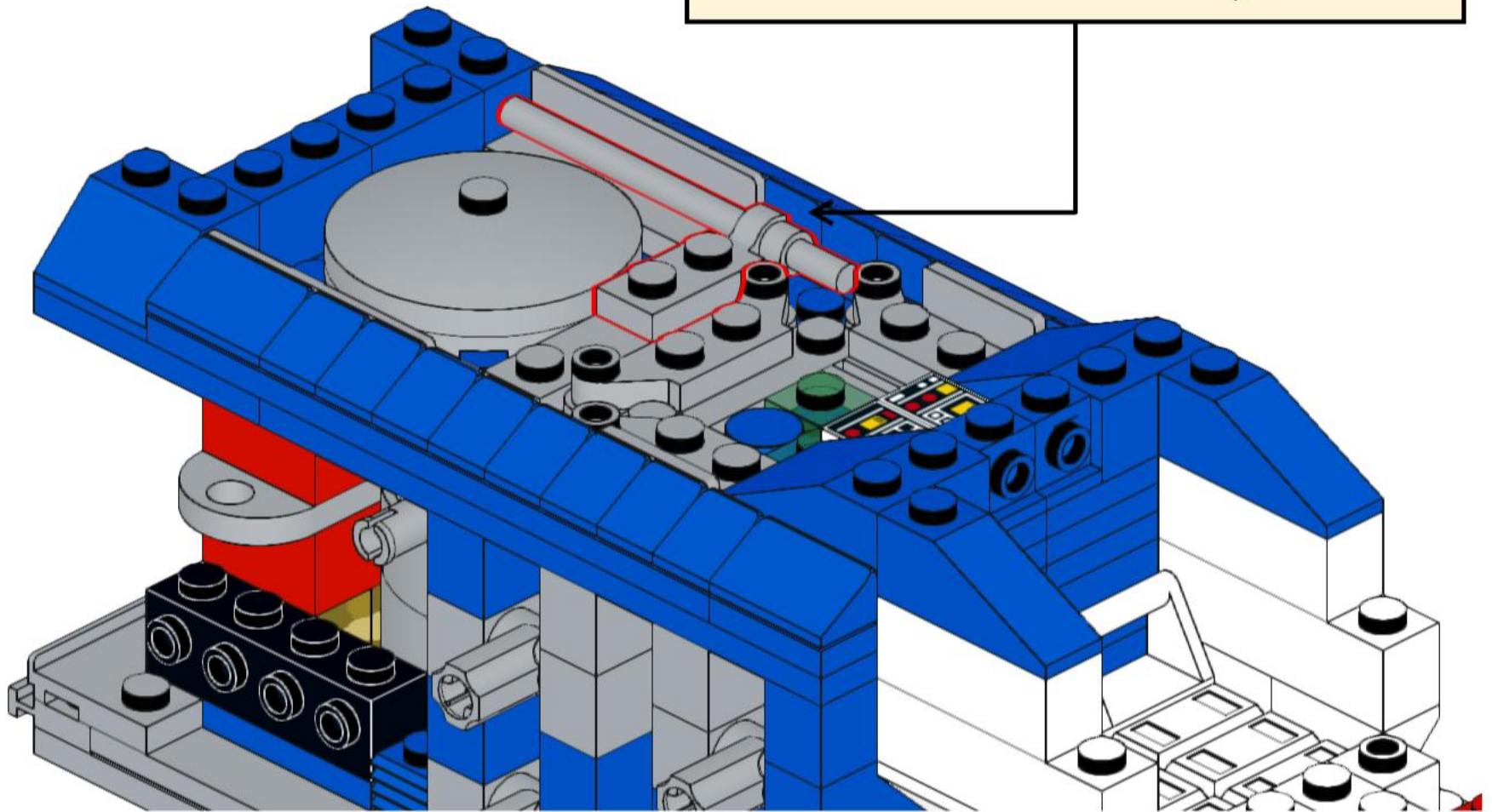
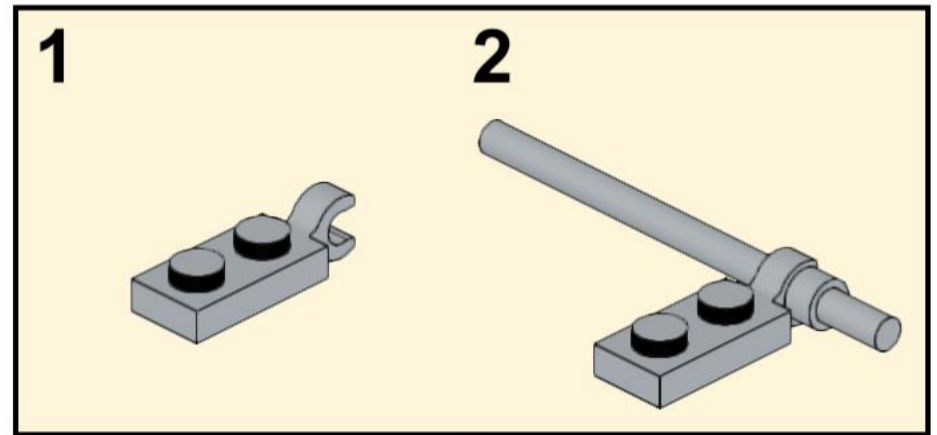
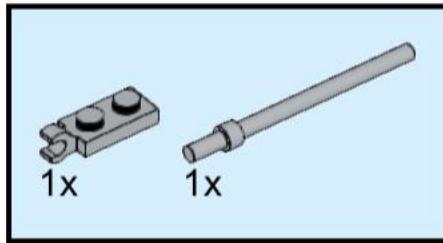

152

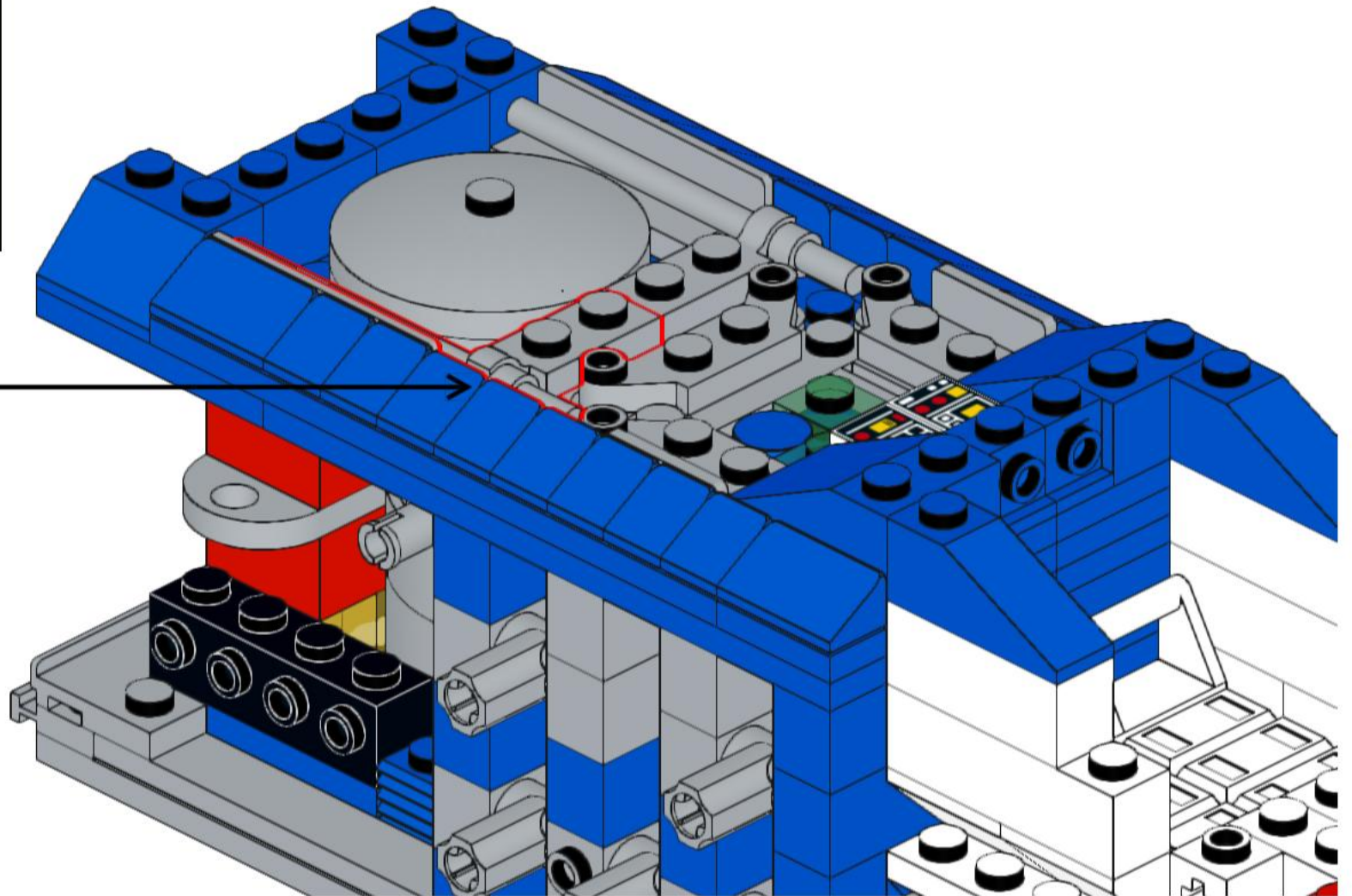
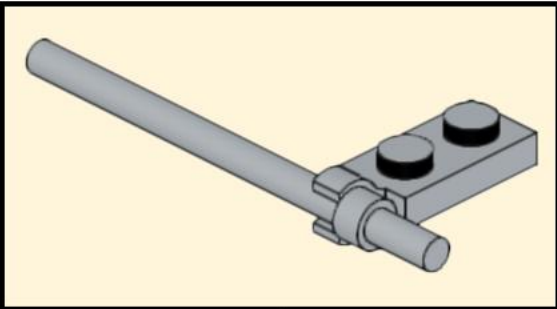
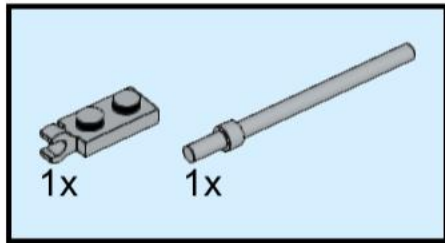

153

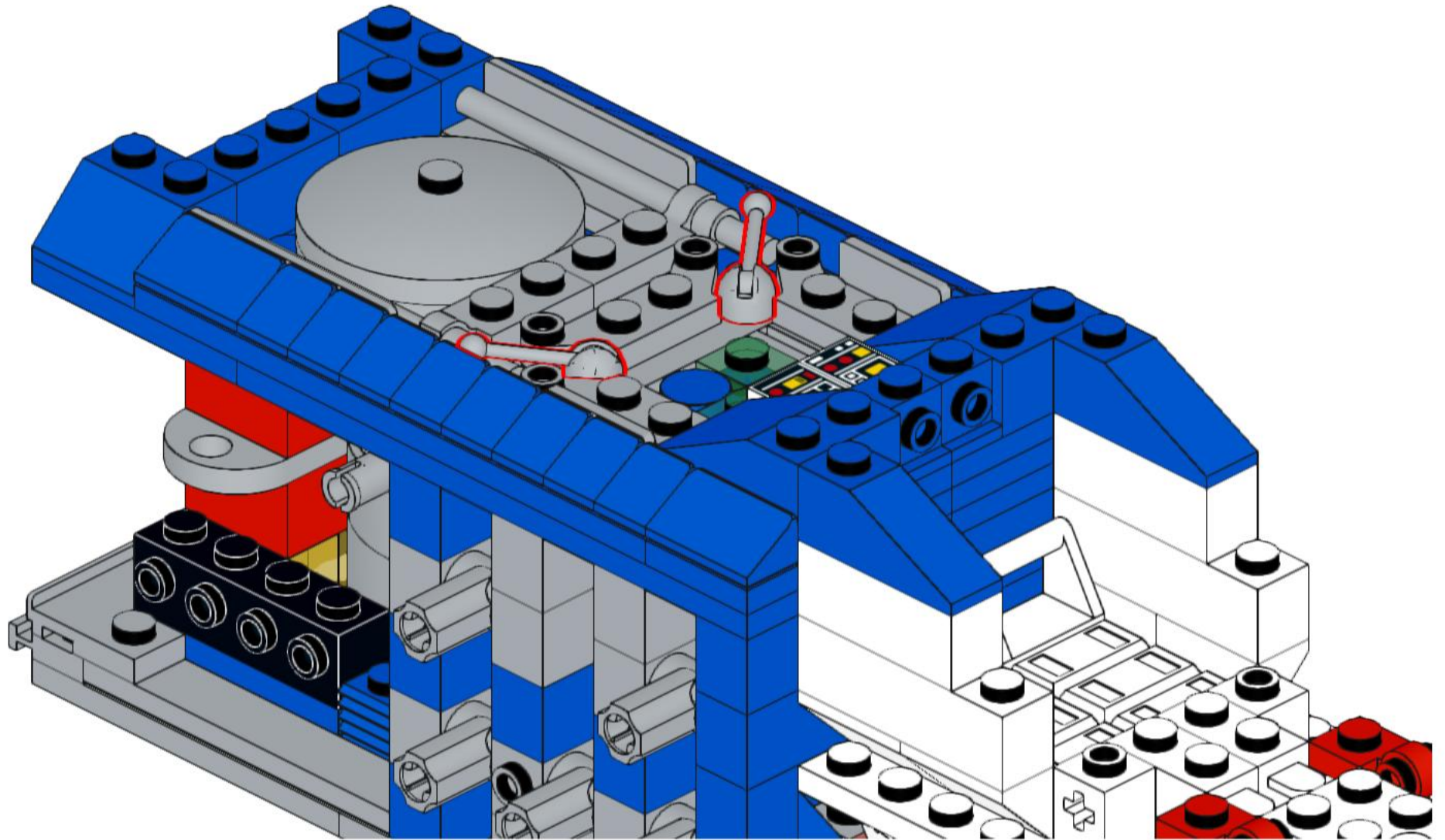
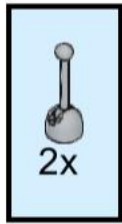

154

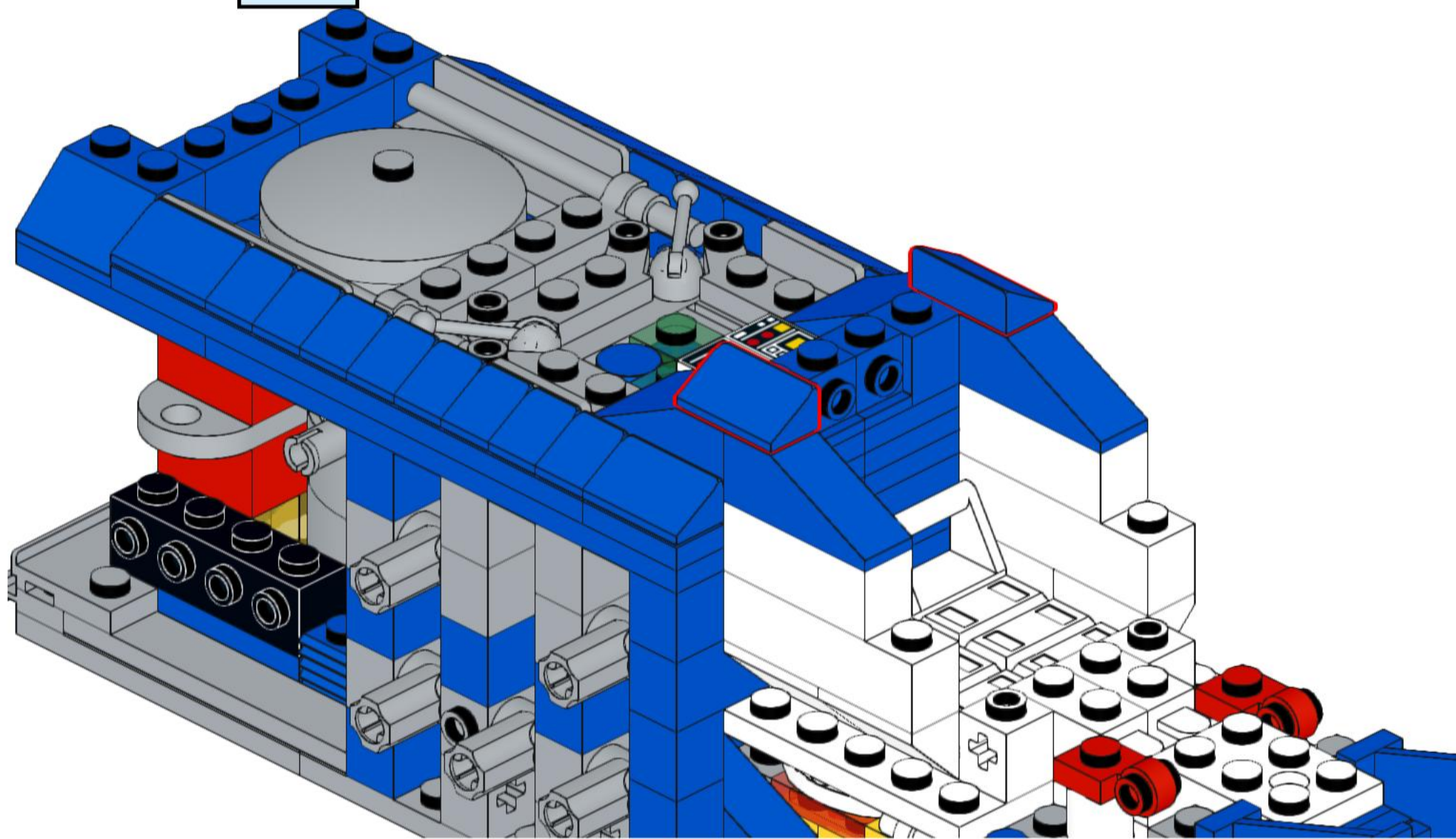
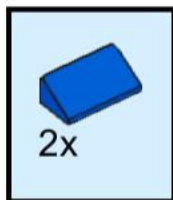

155

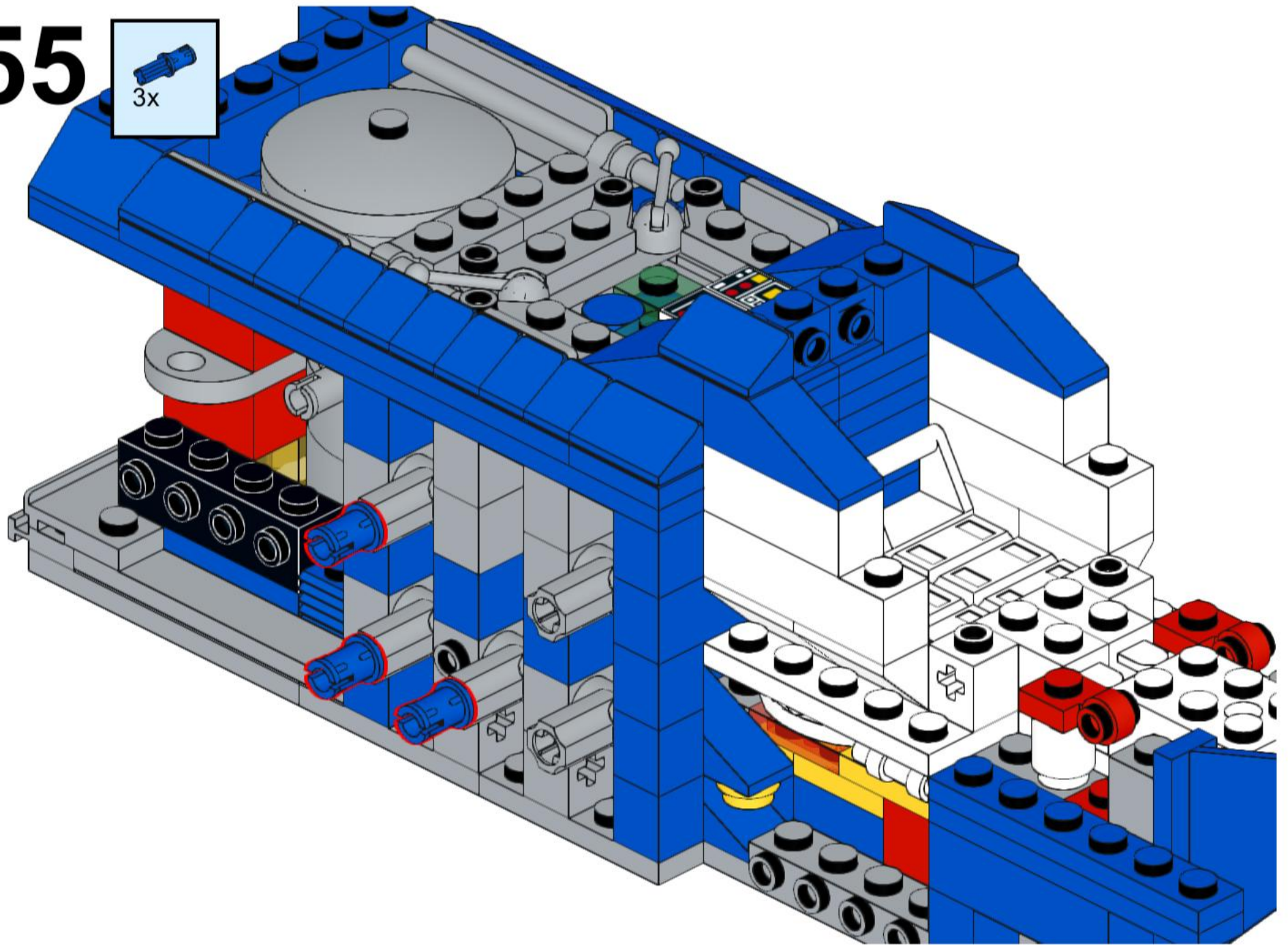

156

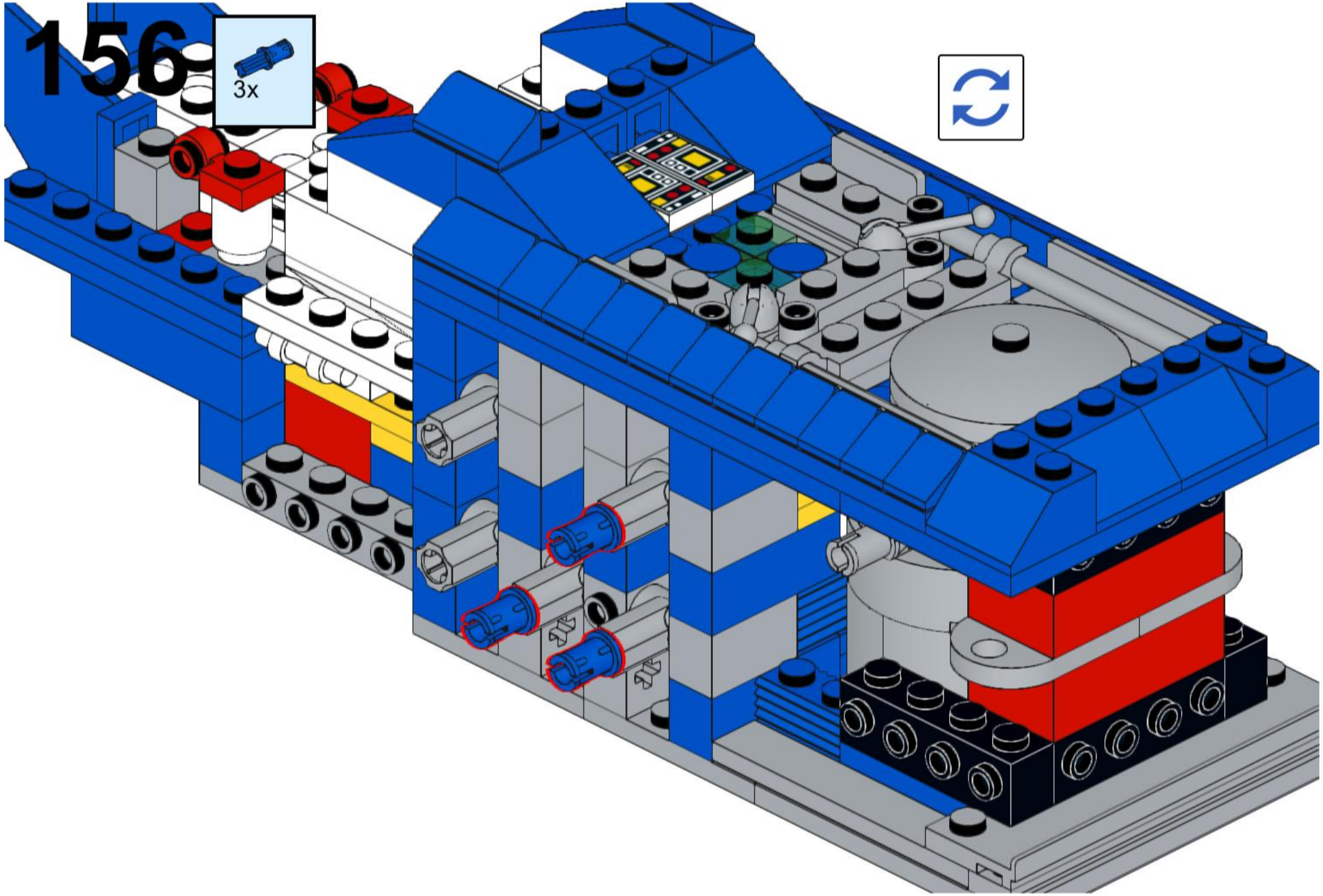

157

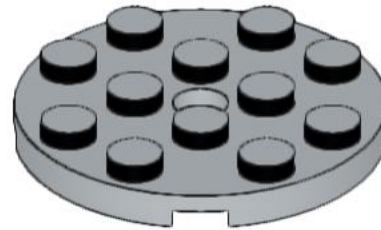
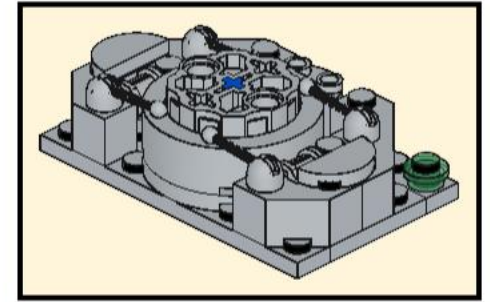
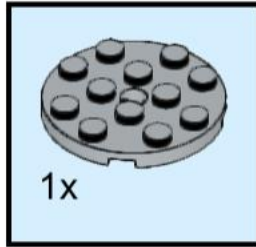

158

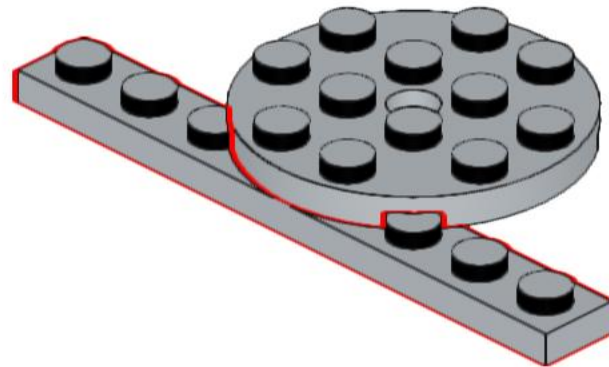
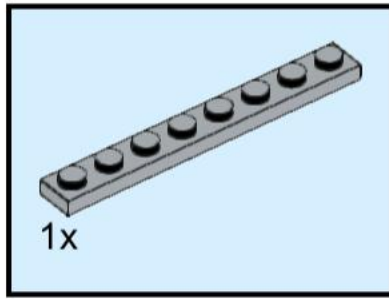

159

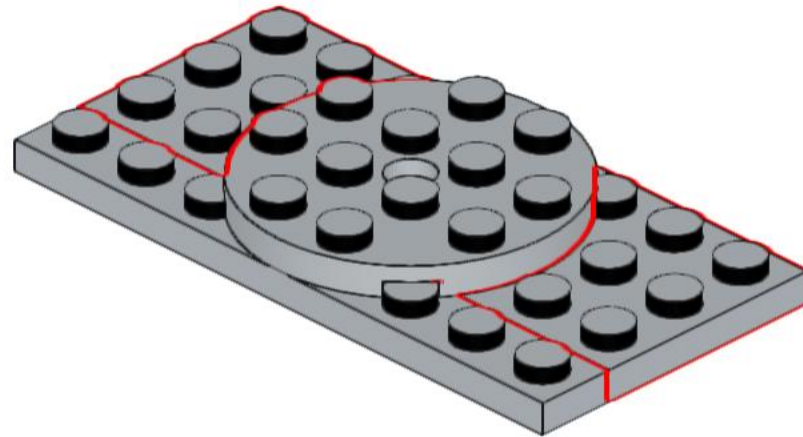
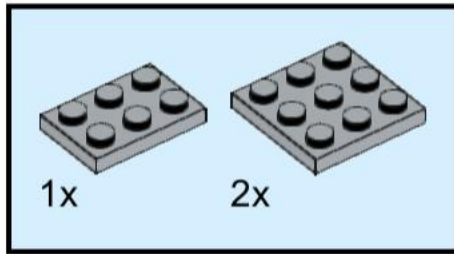

160

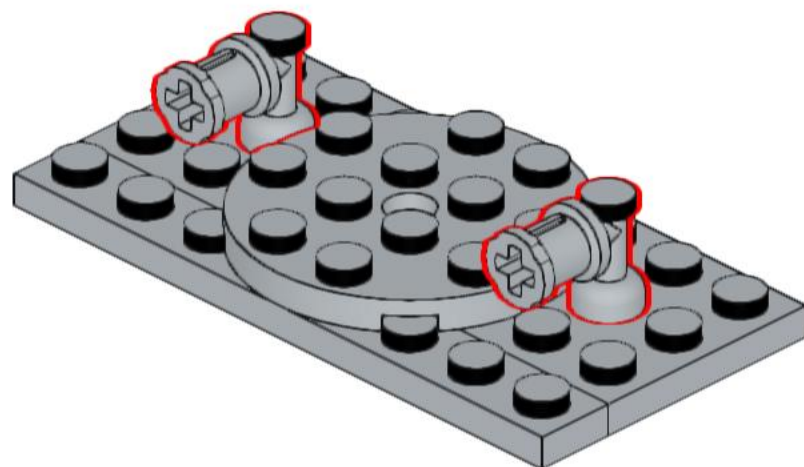
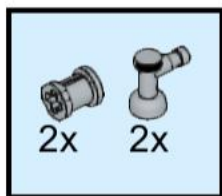

161

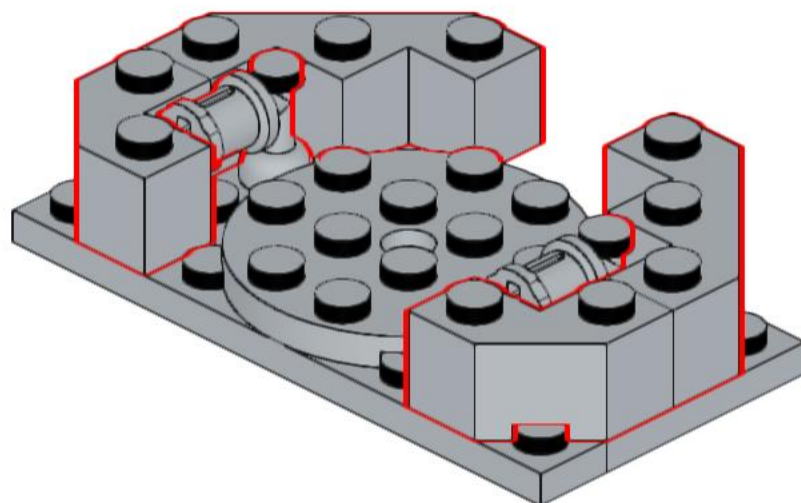
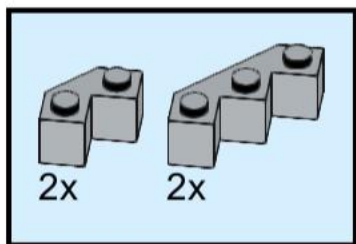

162

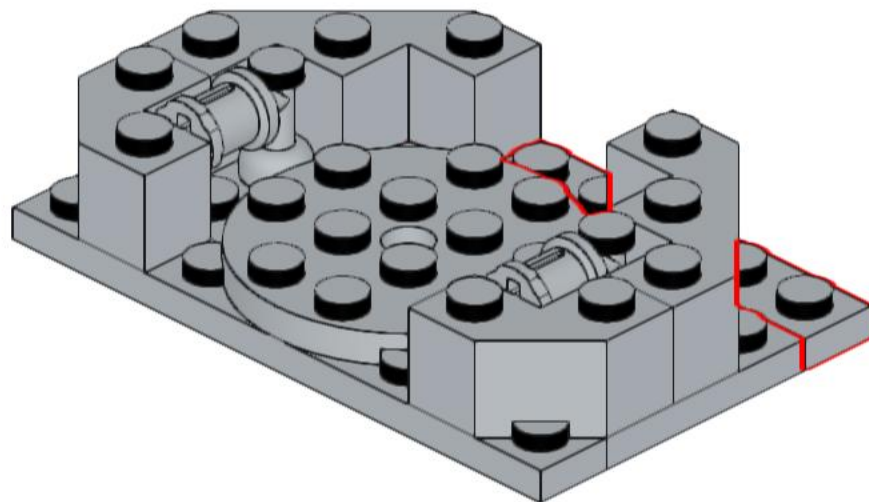
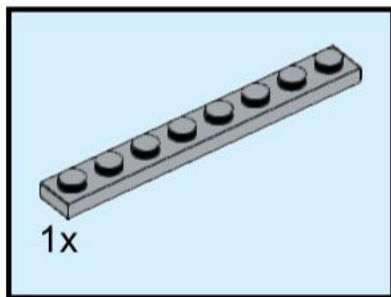

163

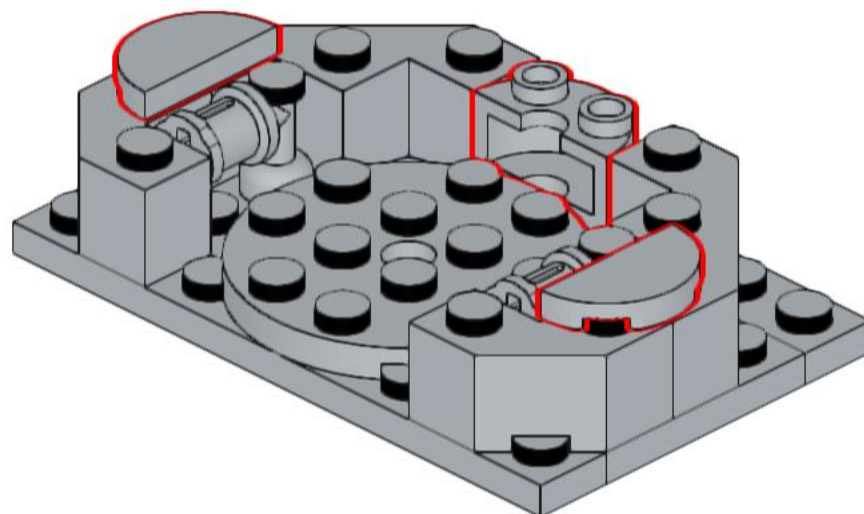
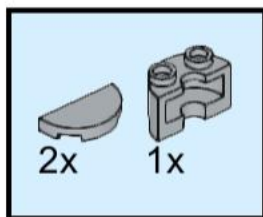

164

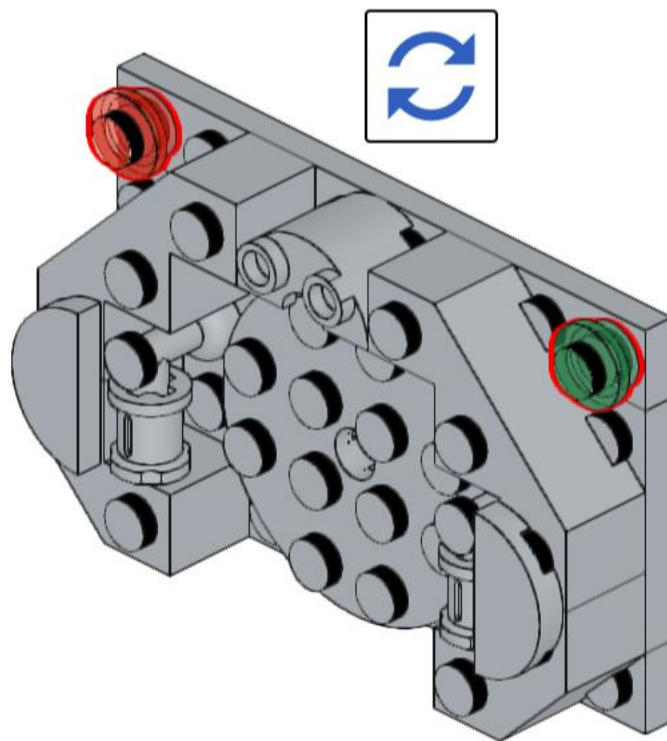
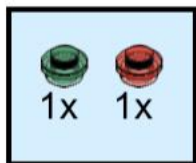

165

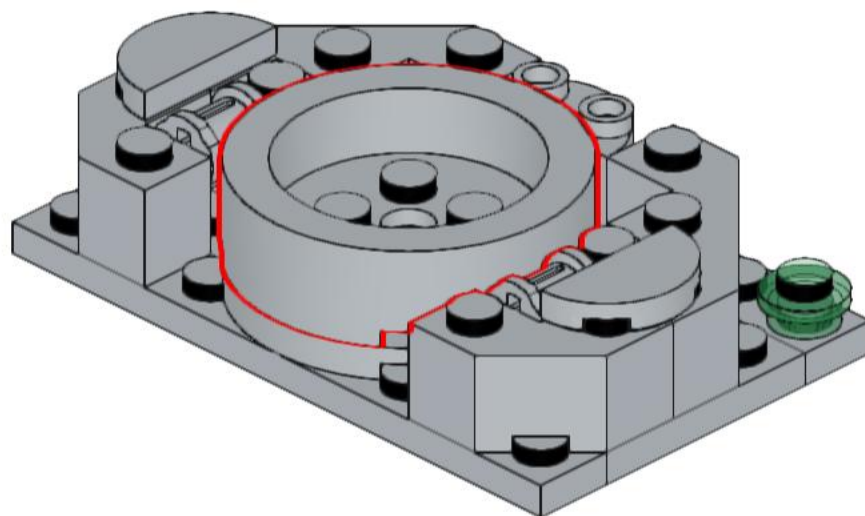
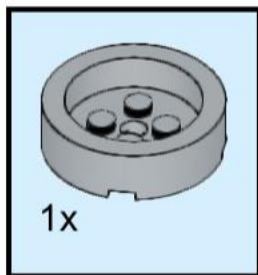

166

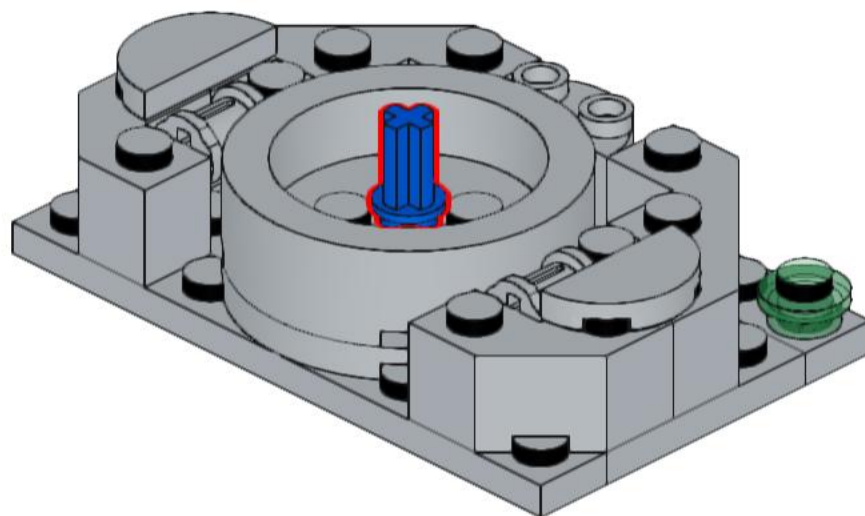

167

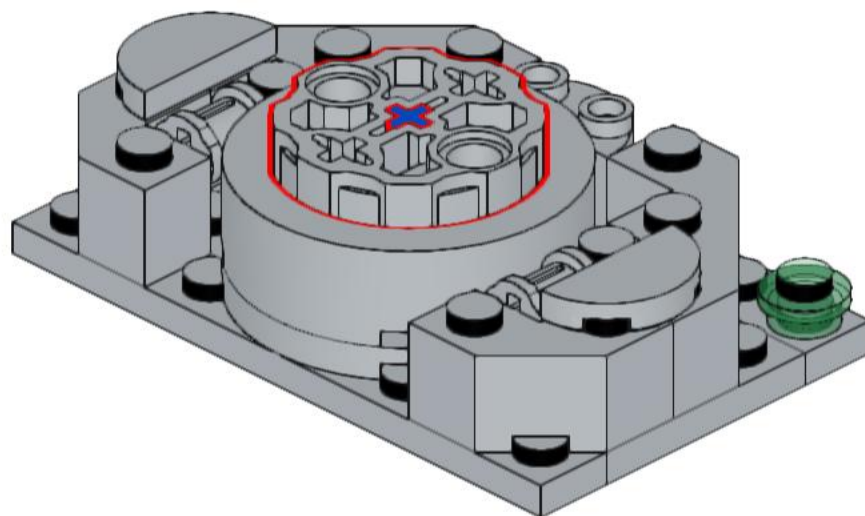
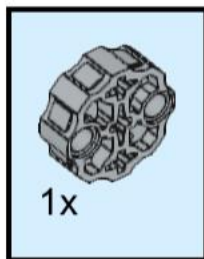

168

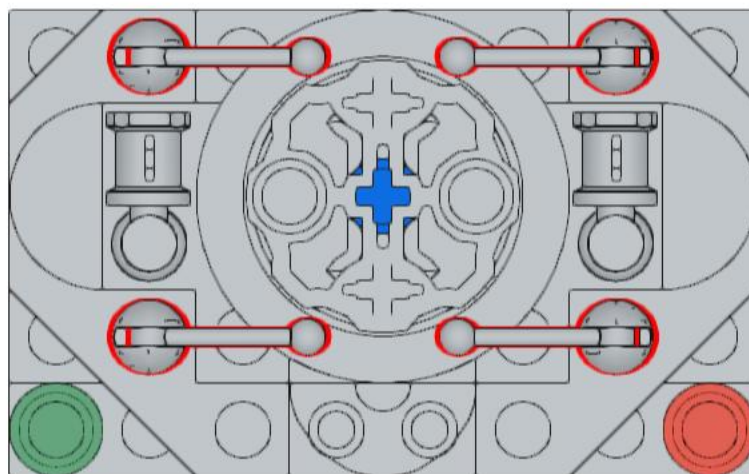
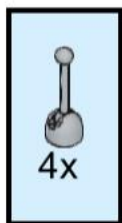

169

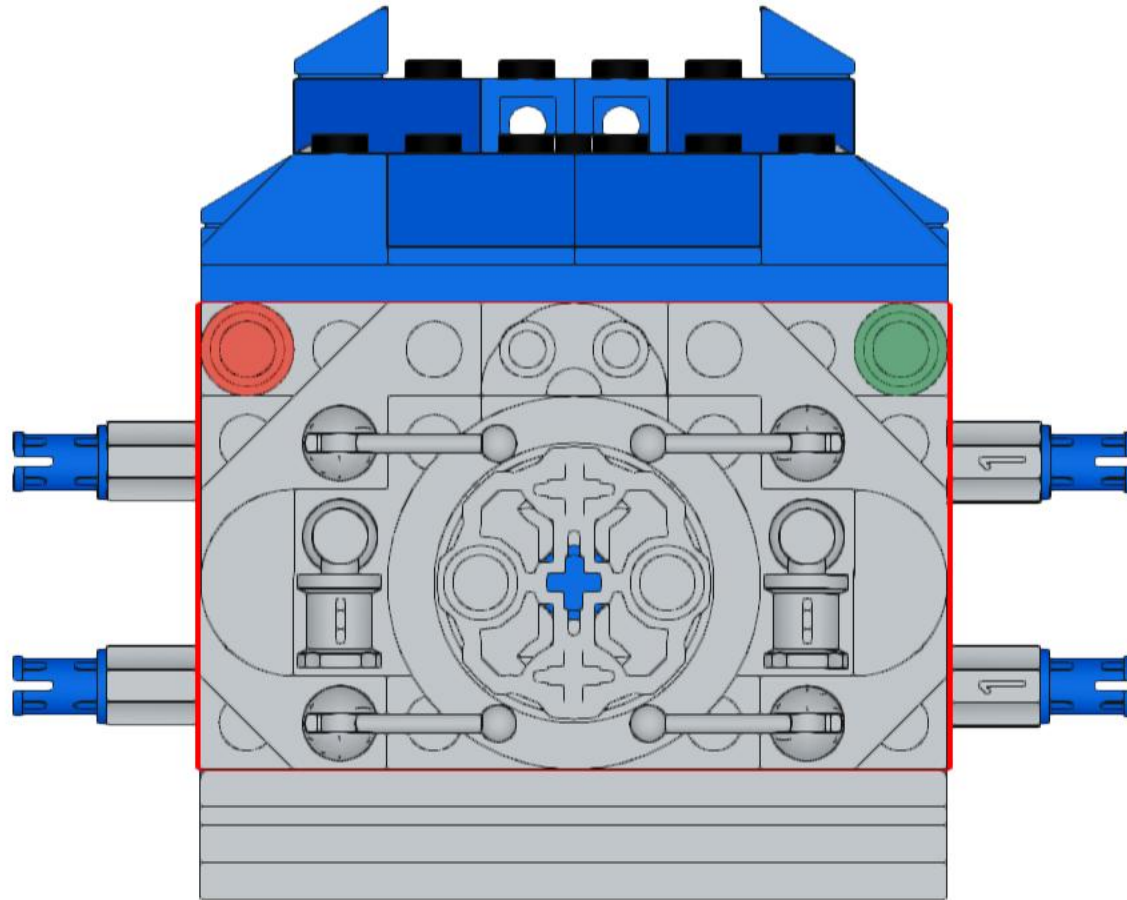

170

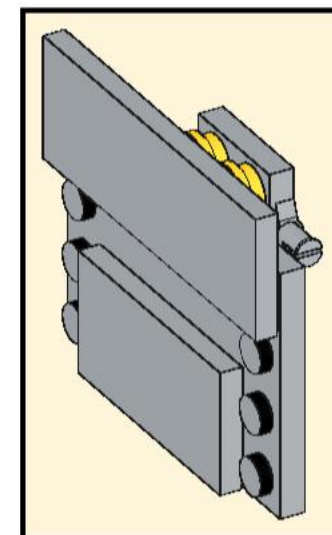
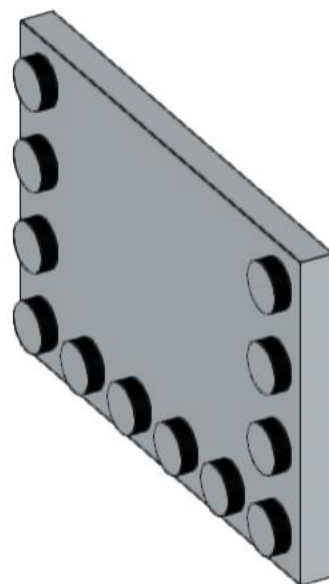
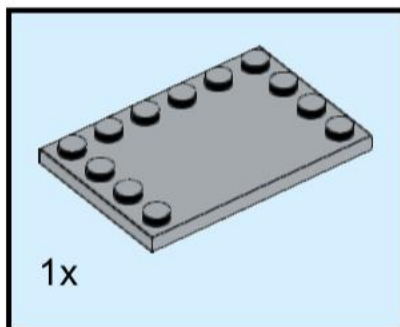

171

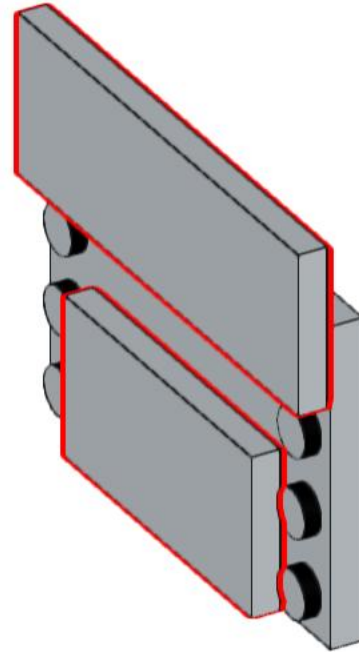
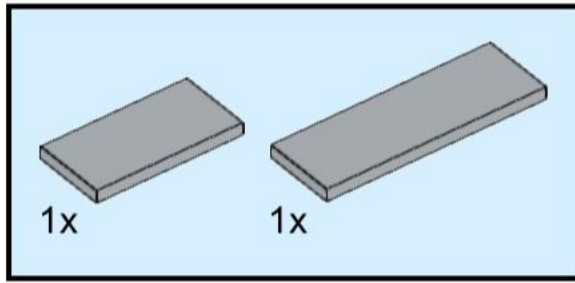

172

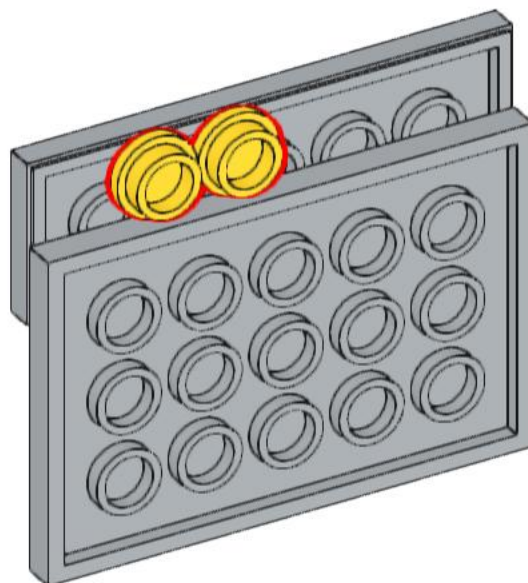

173

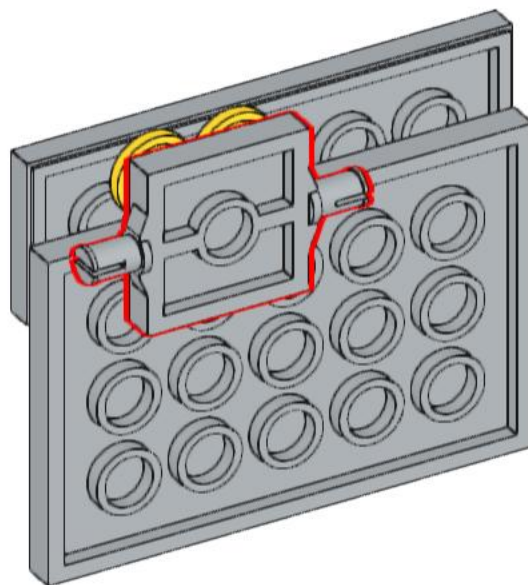
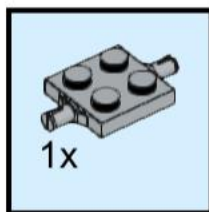

174

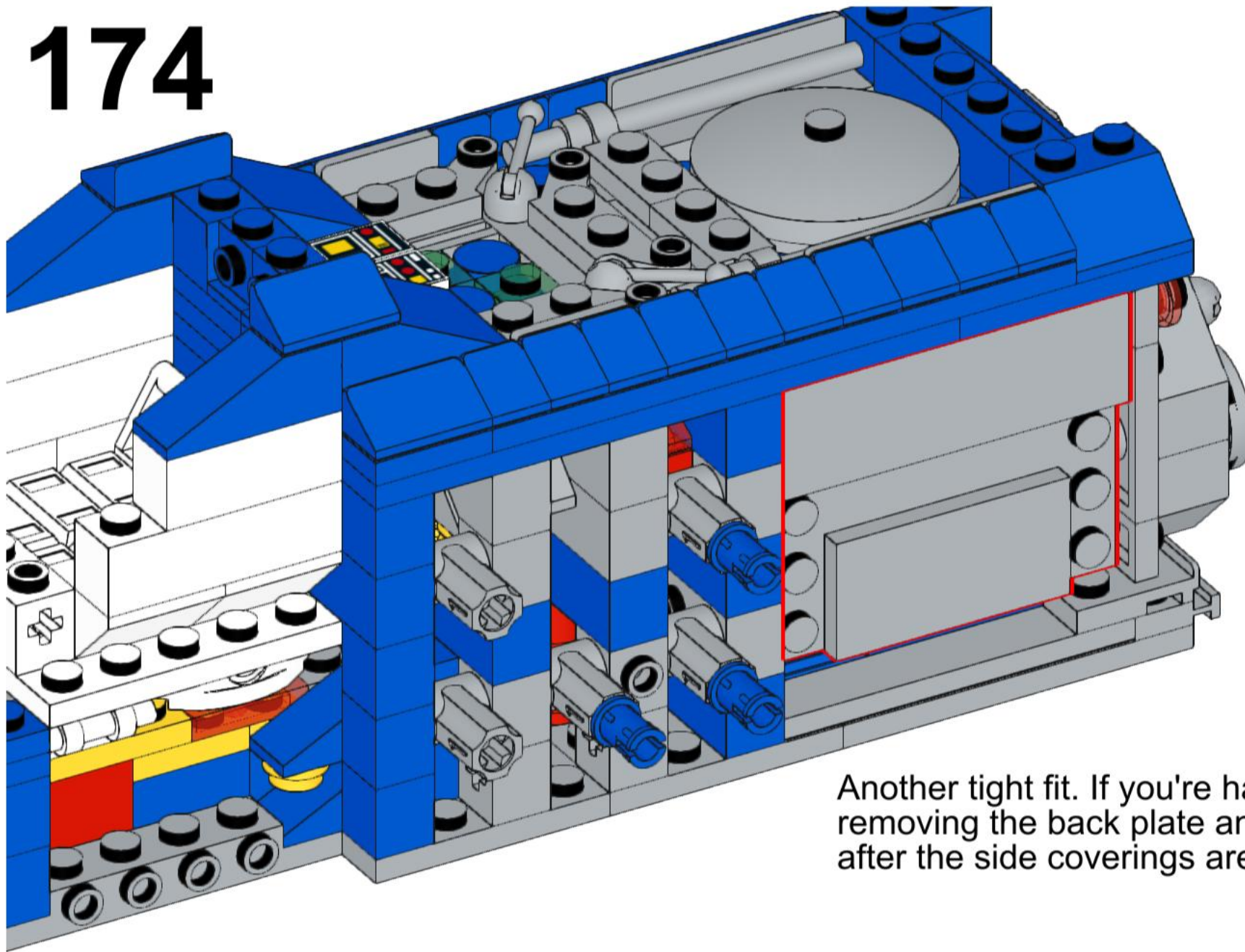

Another tight fit. If you're having trouble try removing the back plate and reinstalling it after the side coverings are in.

175

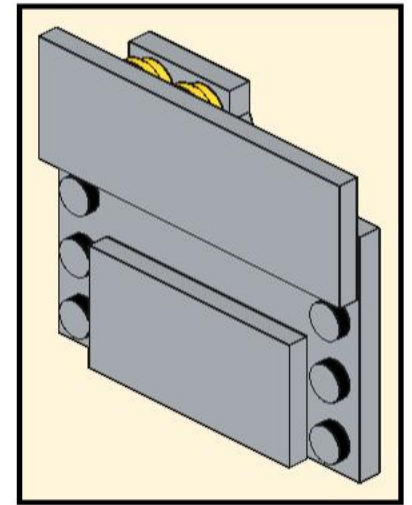
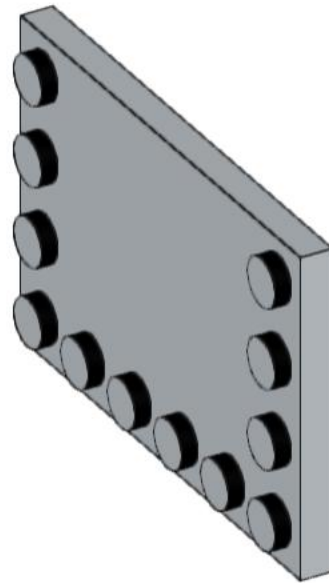
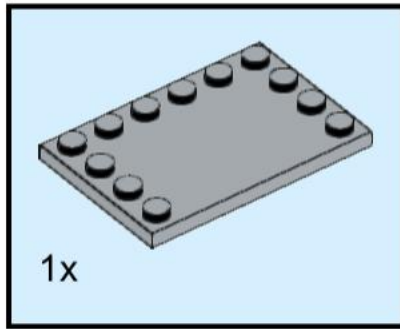

176

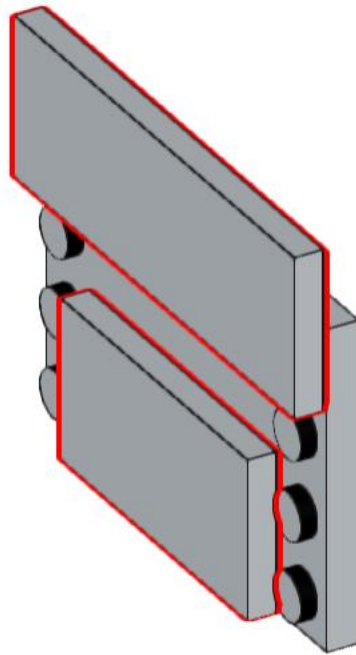
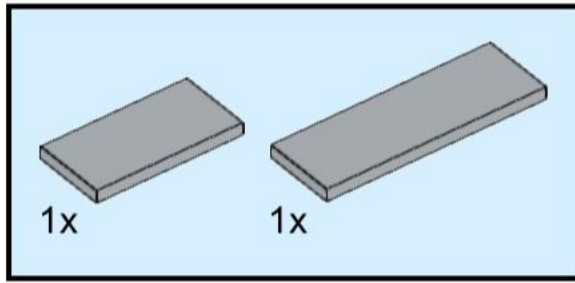

177

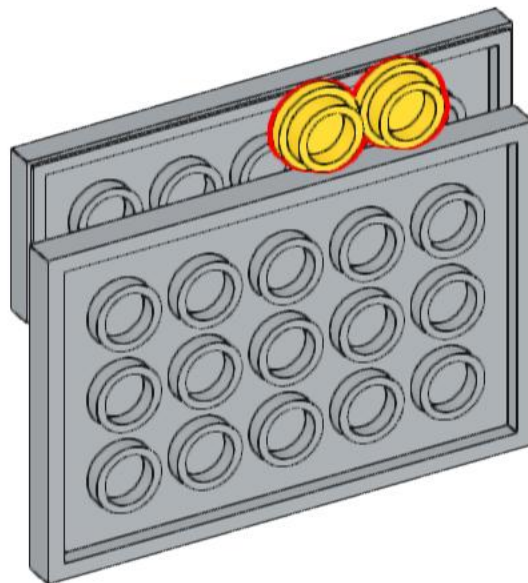

178

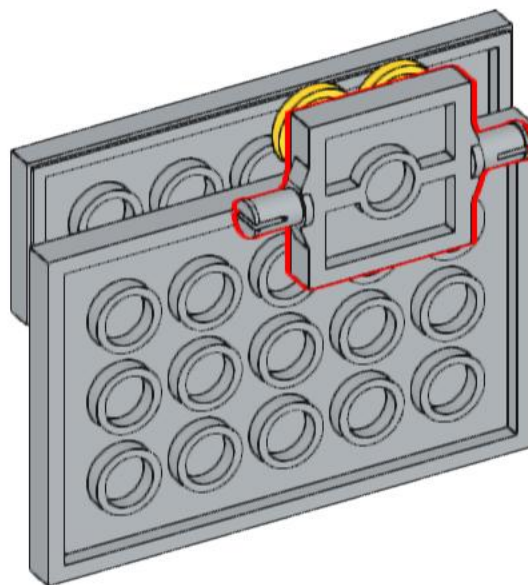
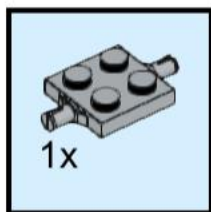

179

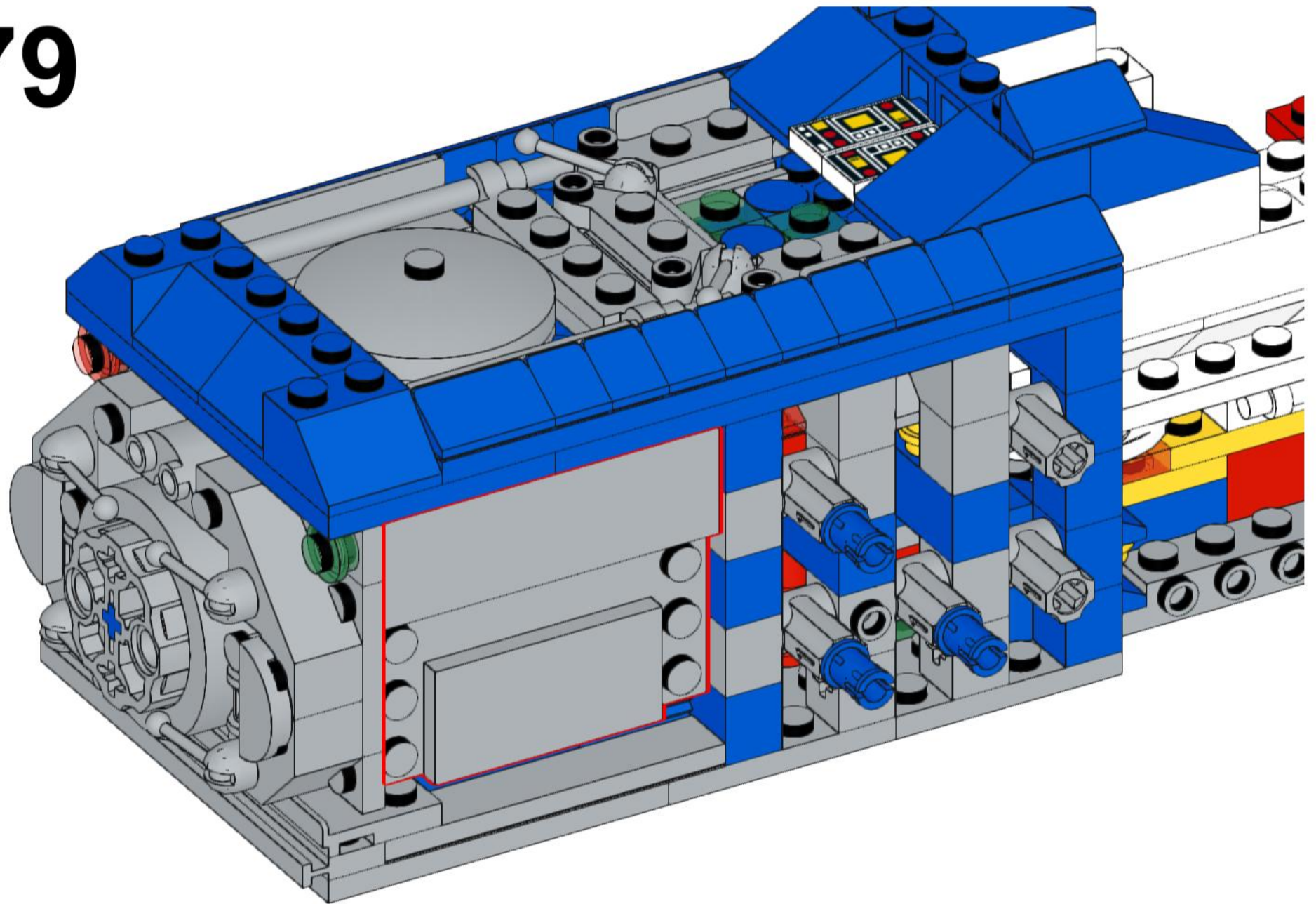

180

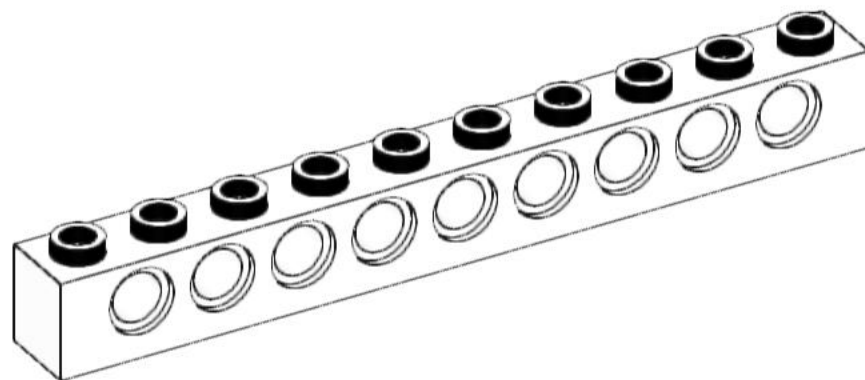
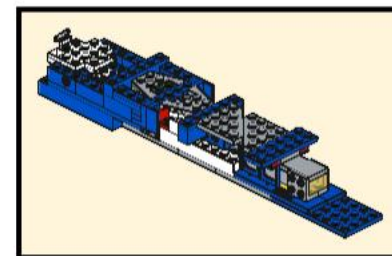
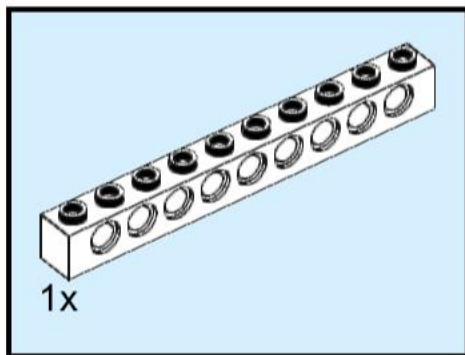

181

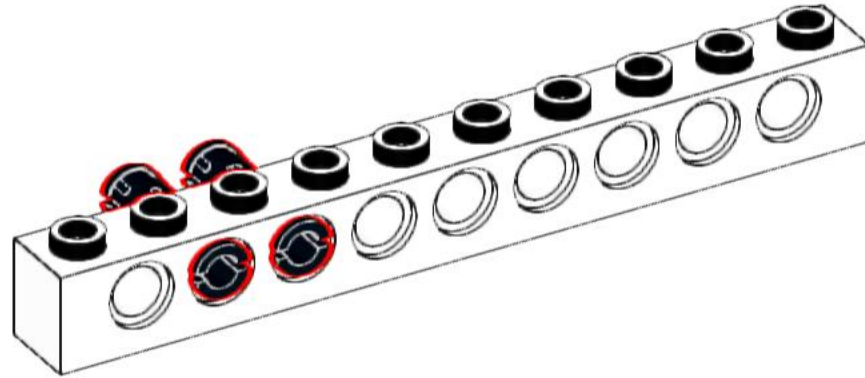

182

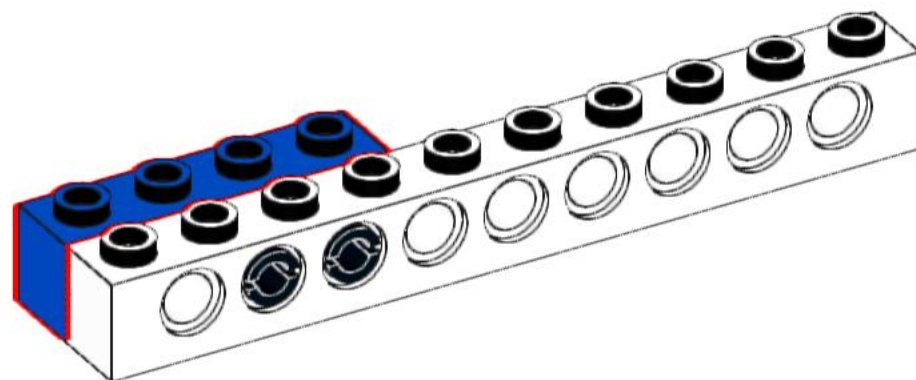
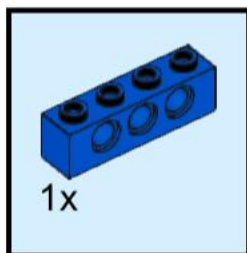

183

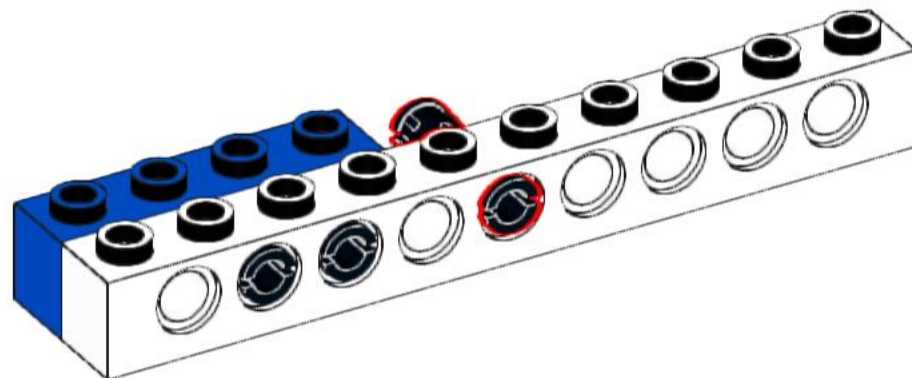

184

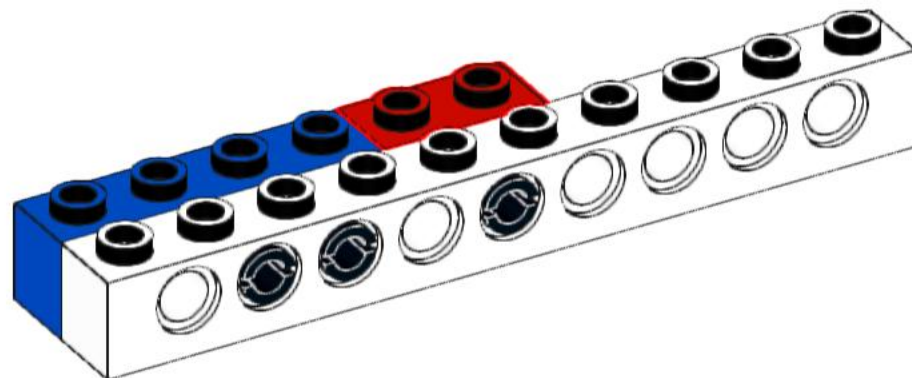
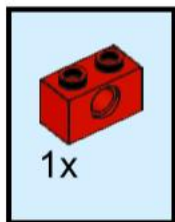

185

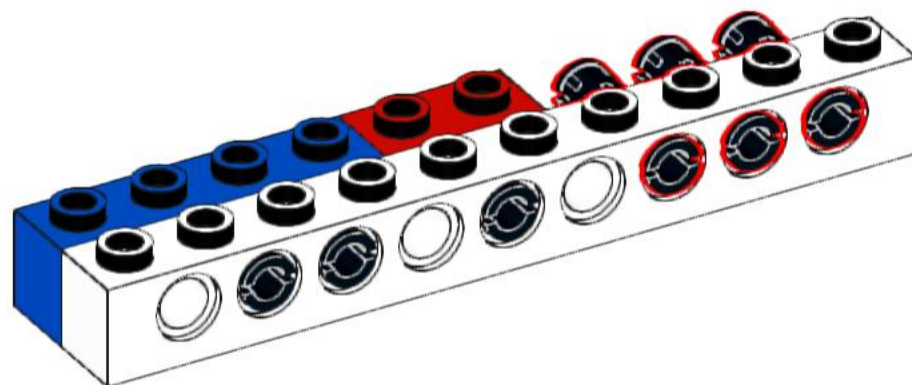

186

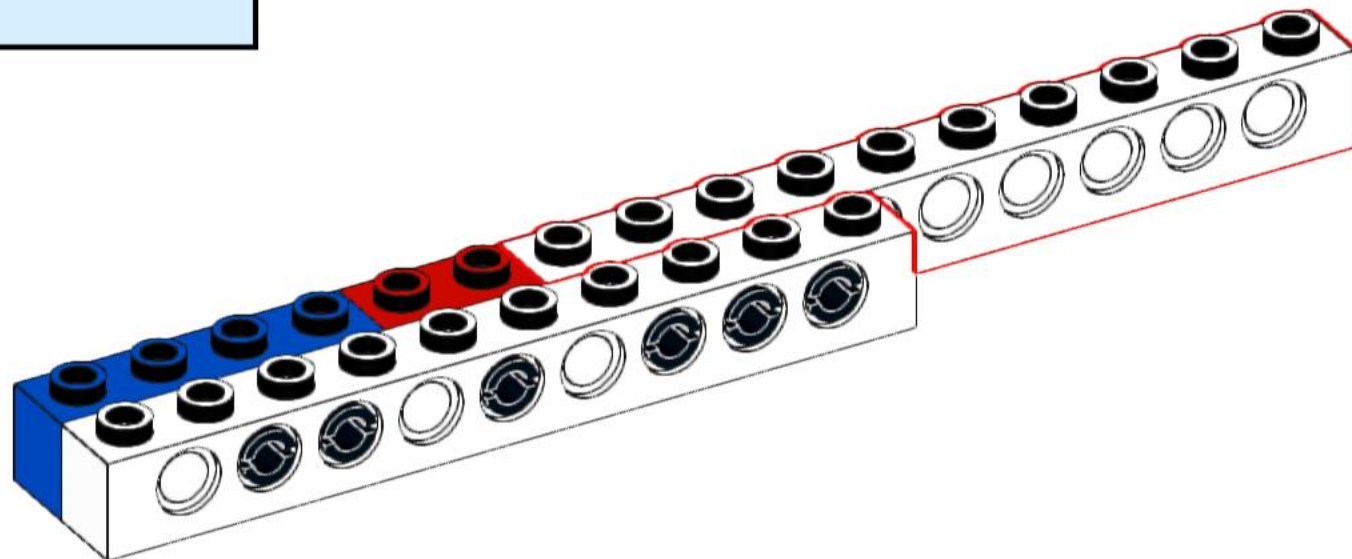
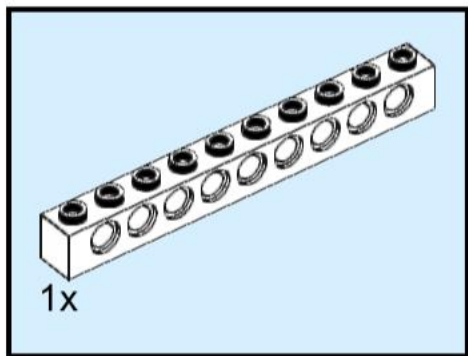

187

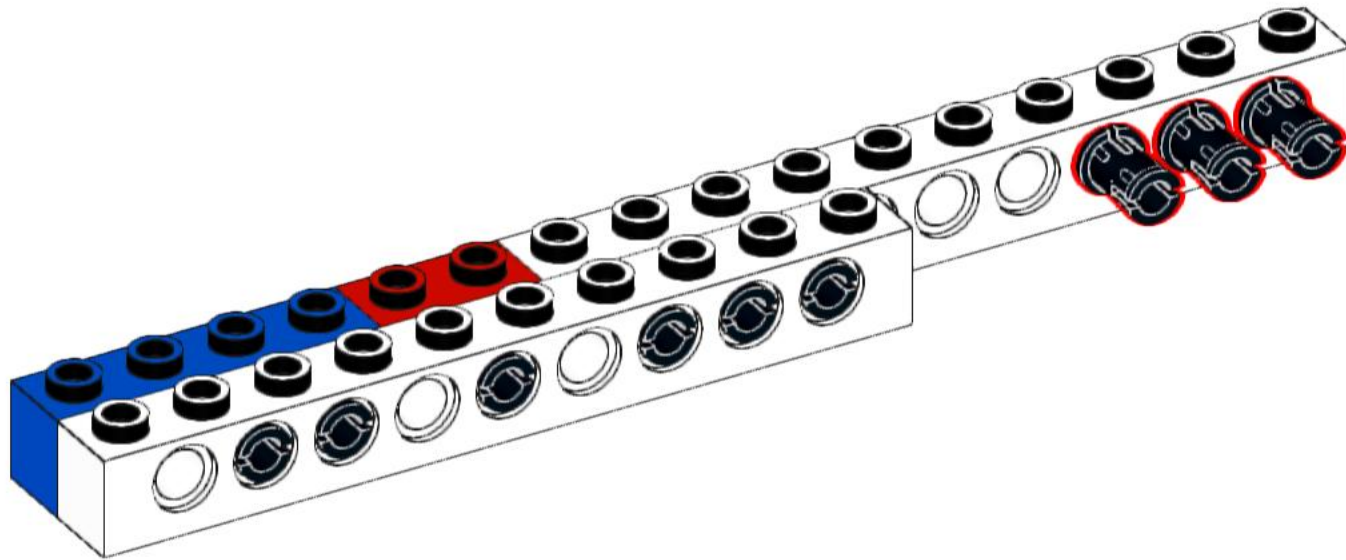

188

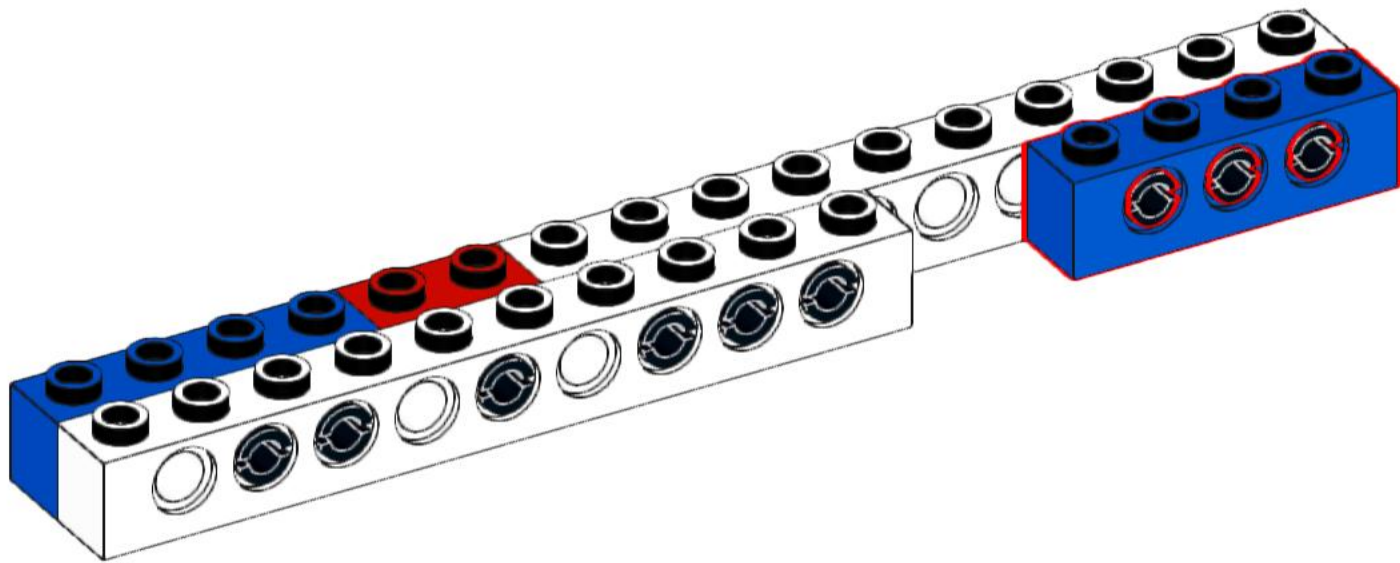
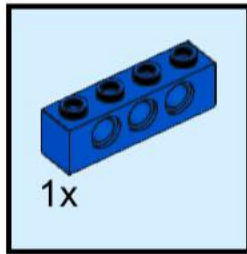

189

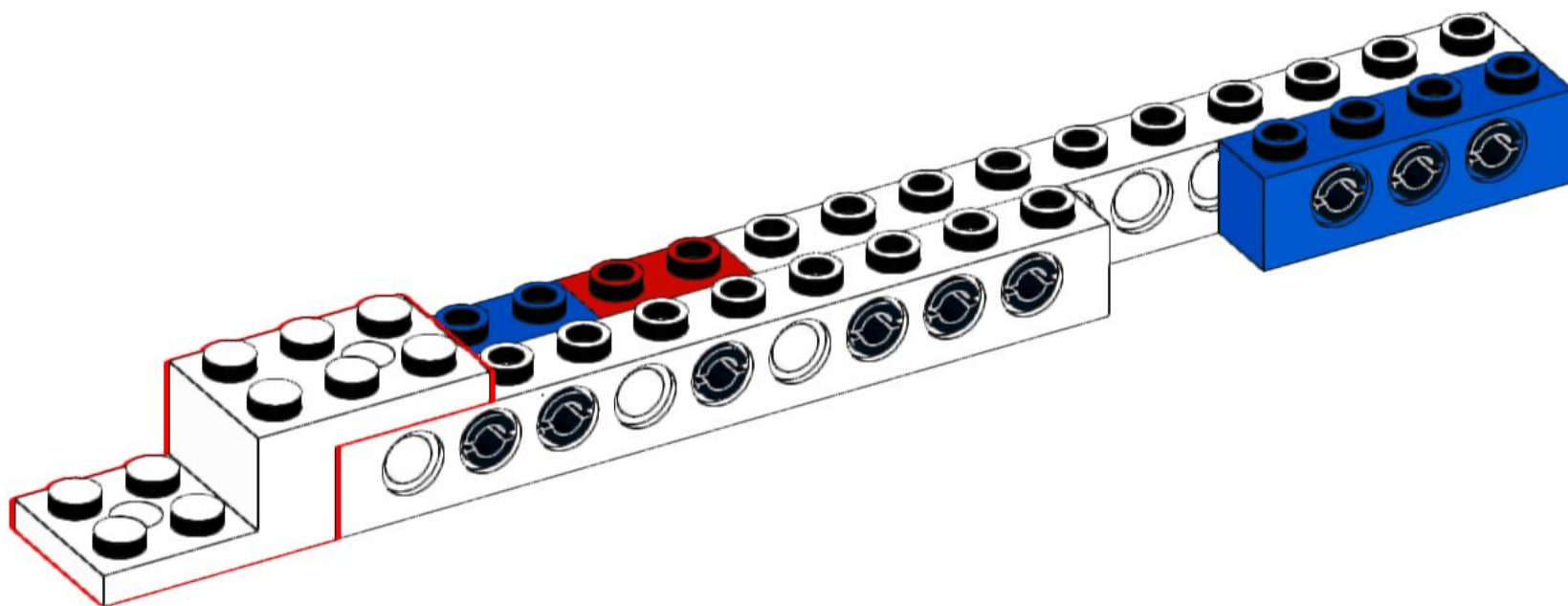
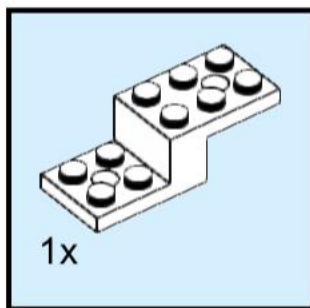

191

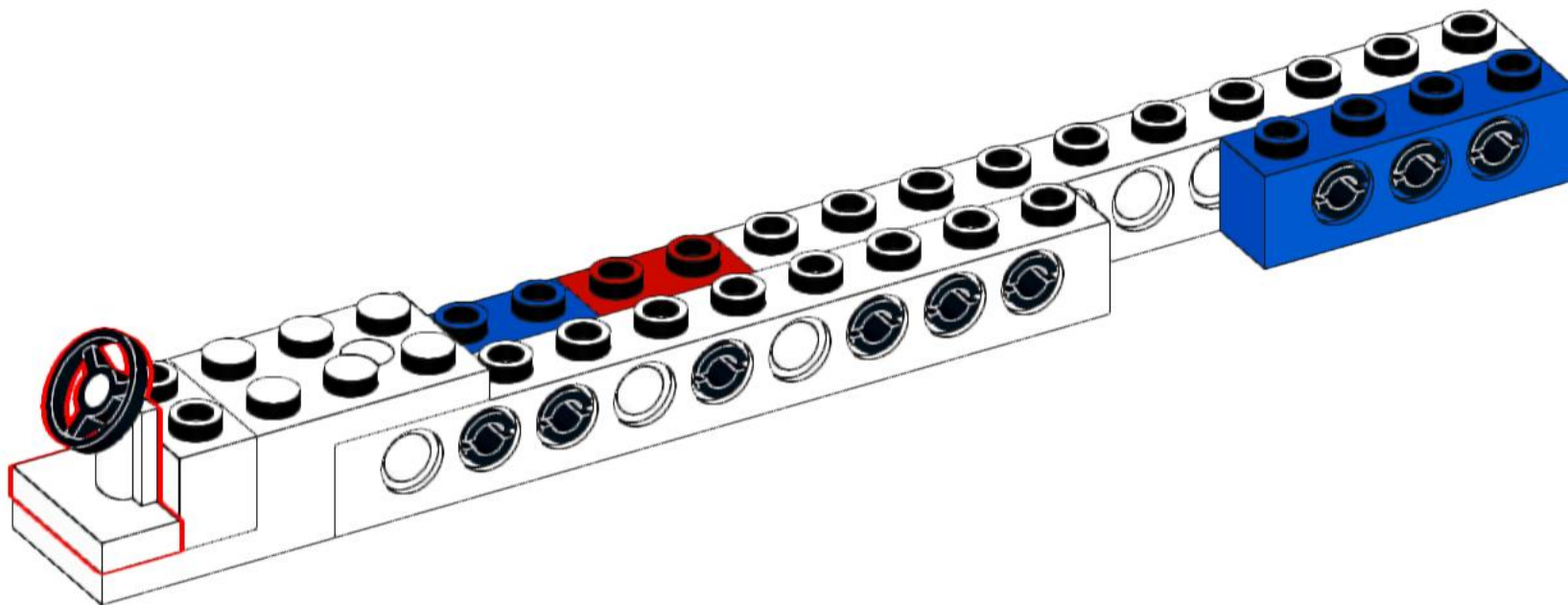
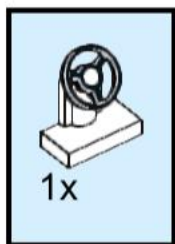

192

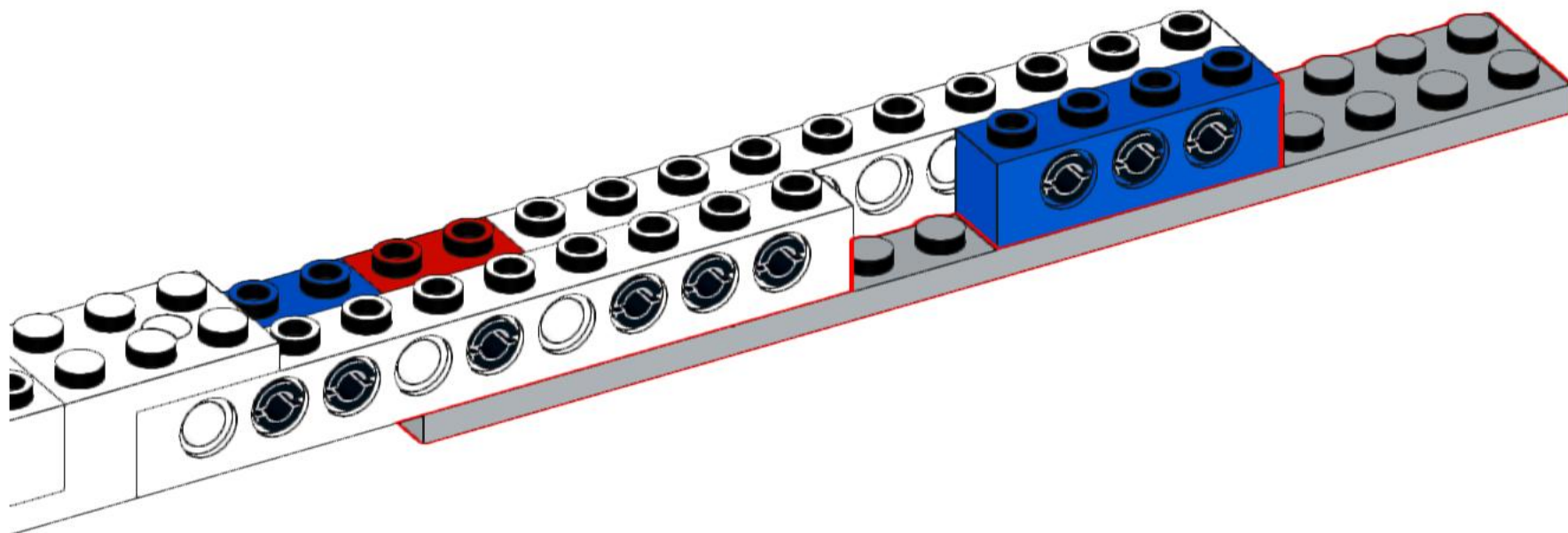
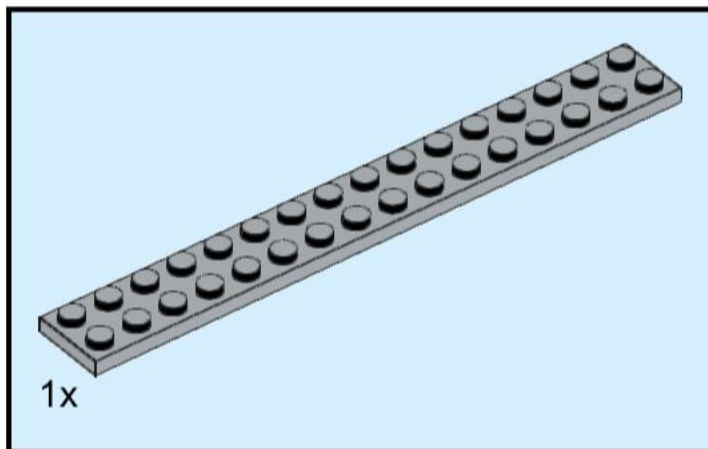

193

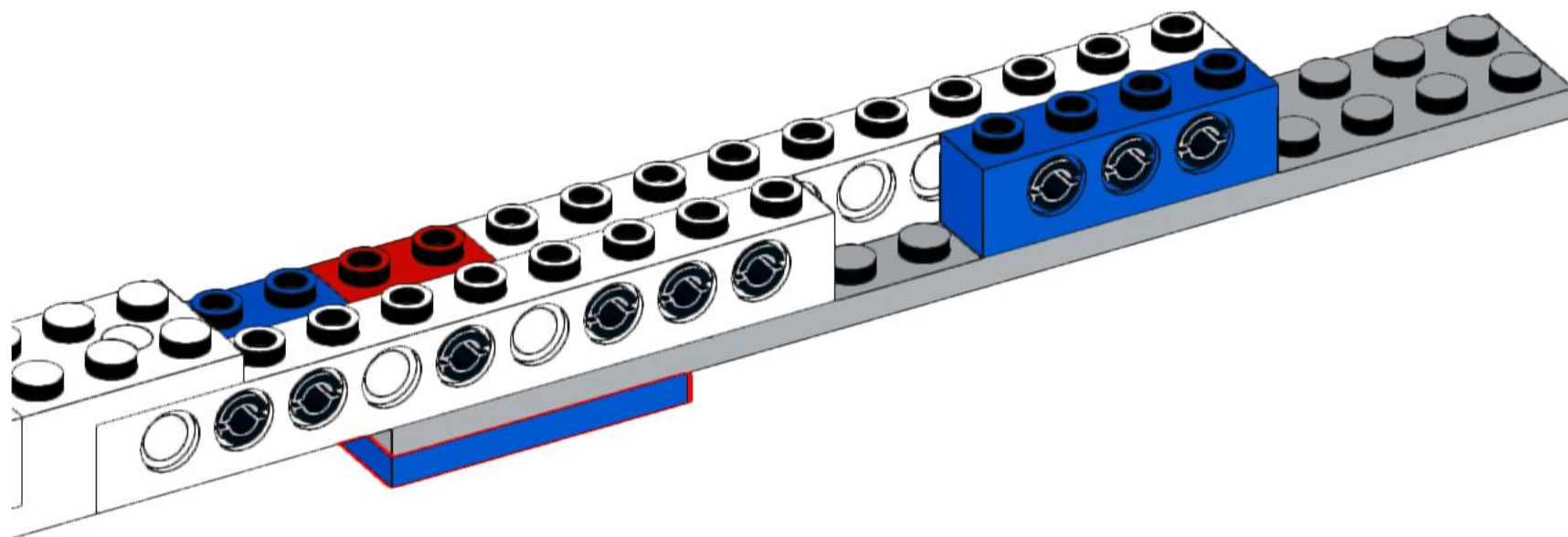
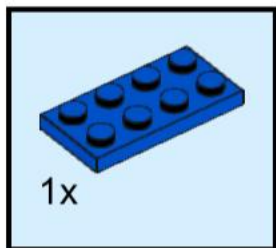

194

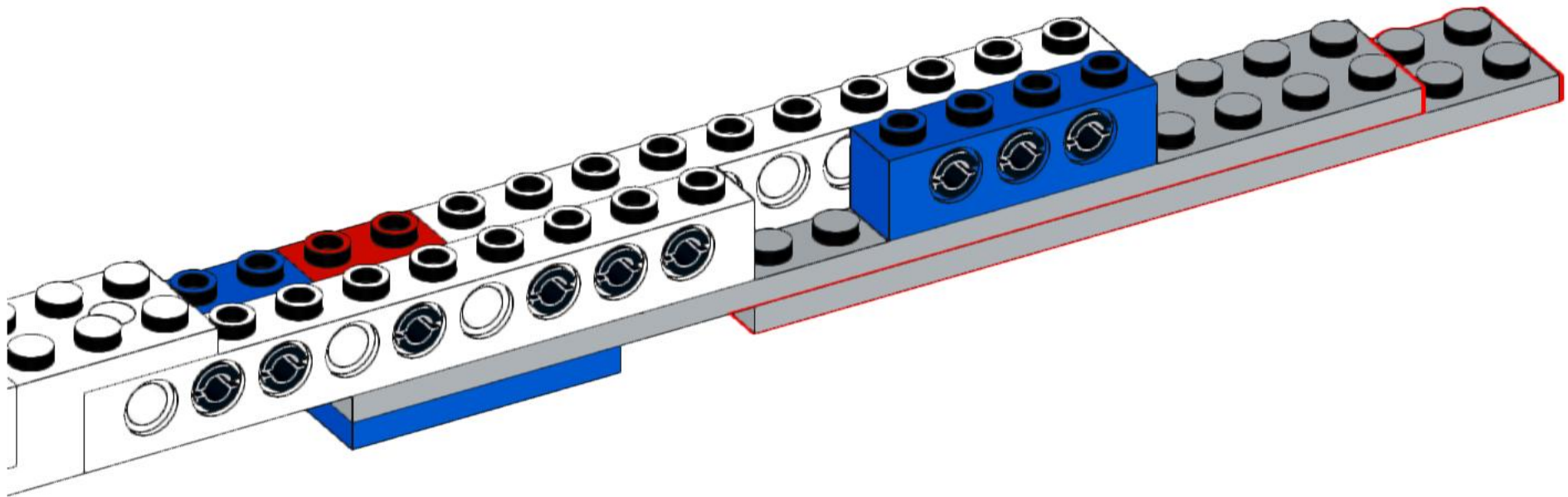
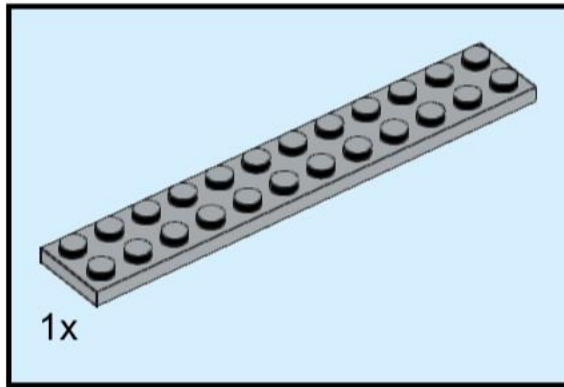

195

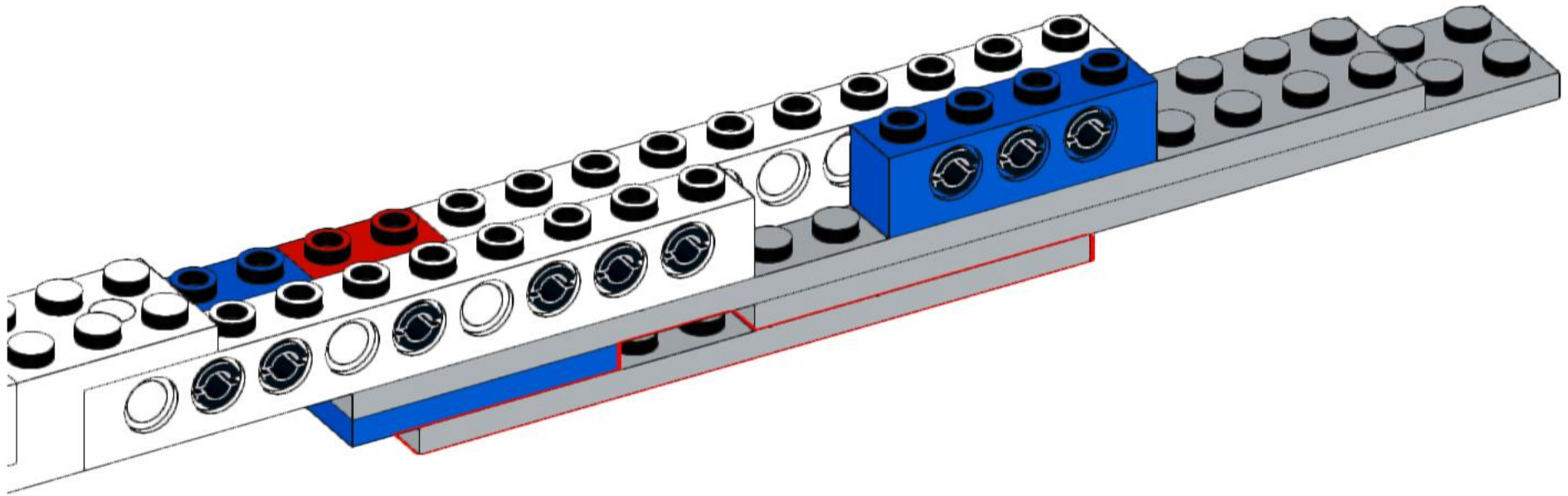
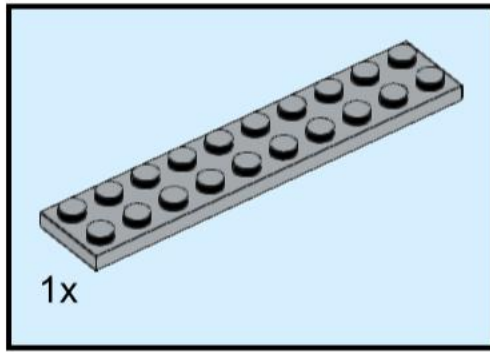

196

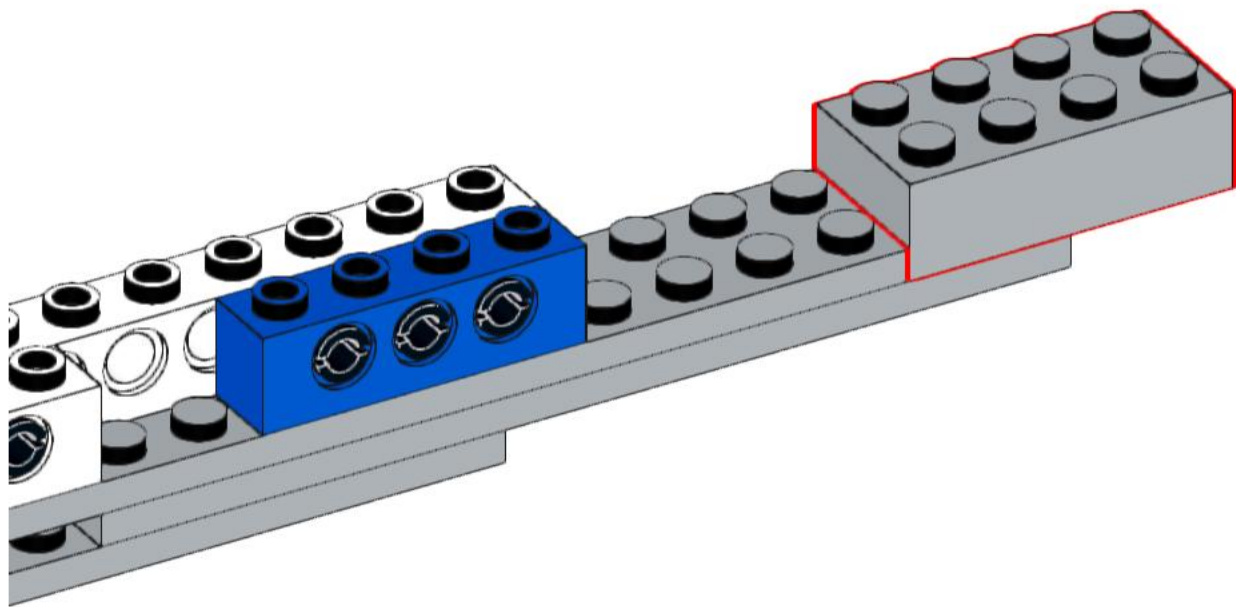
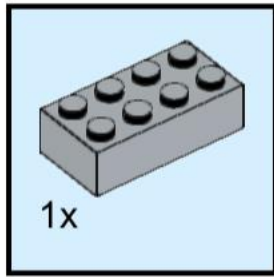

197

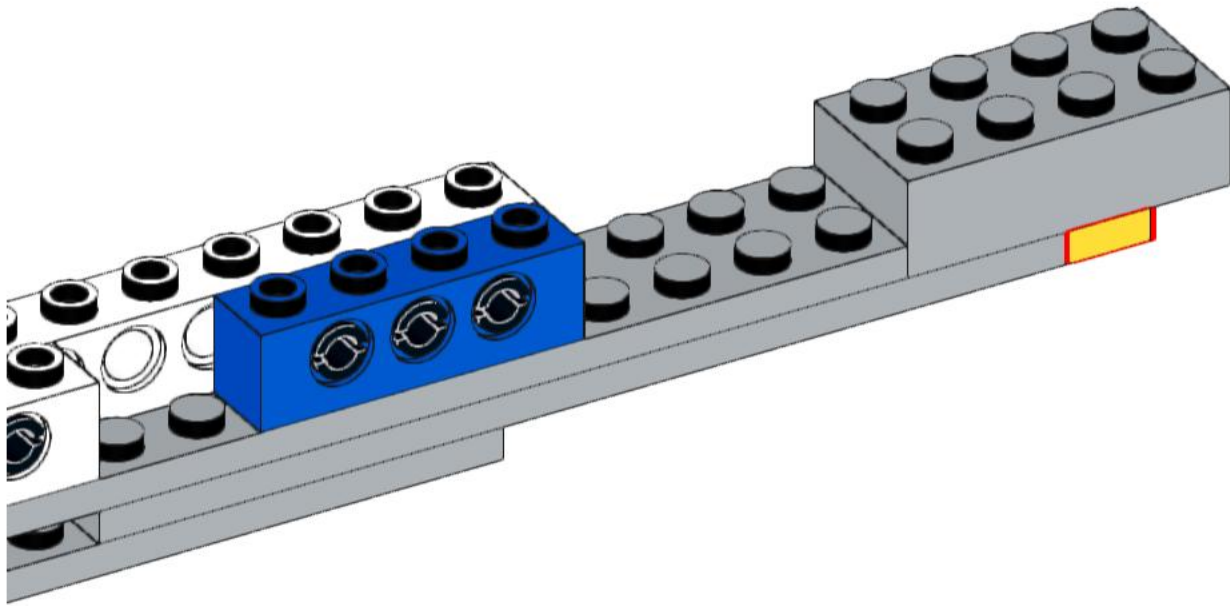
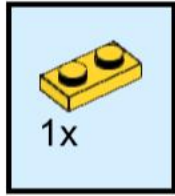

198

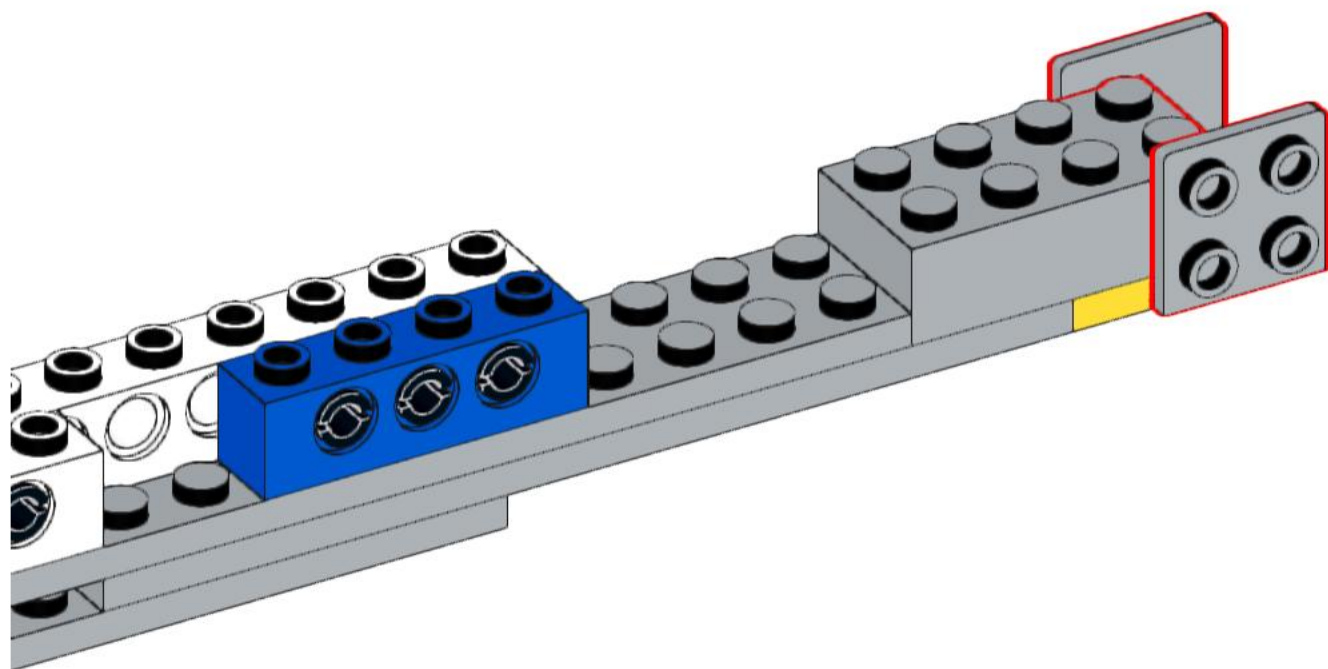
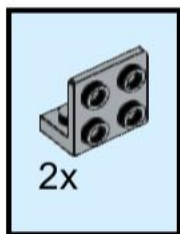

199

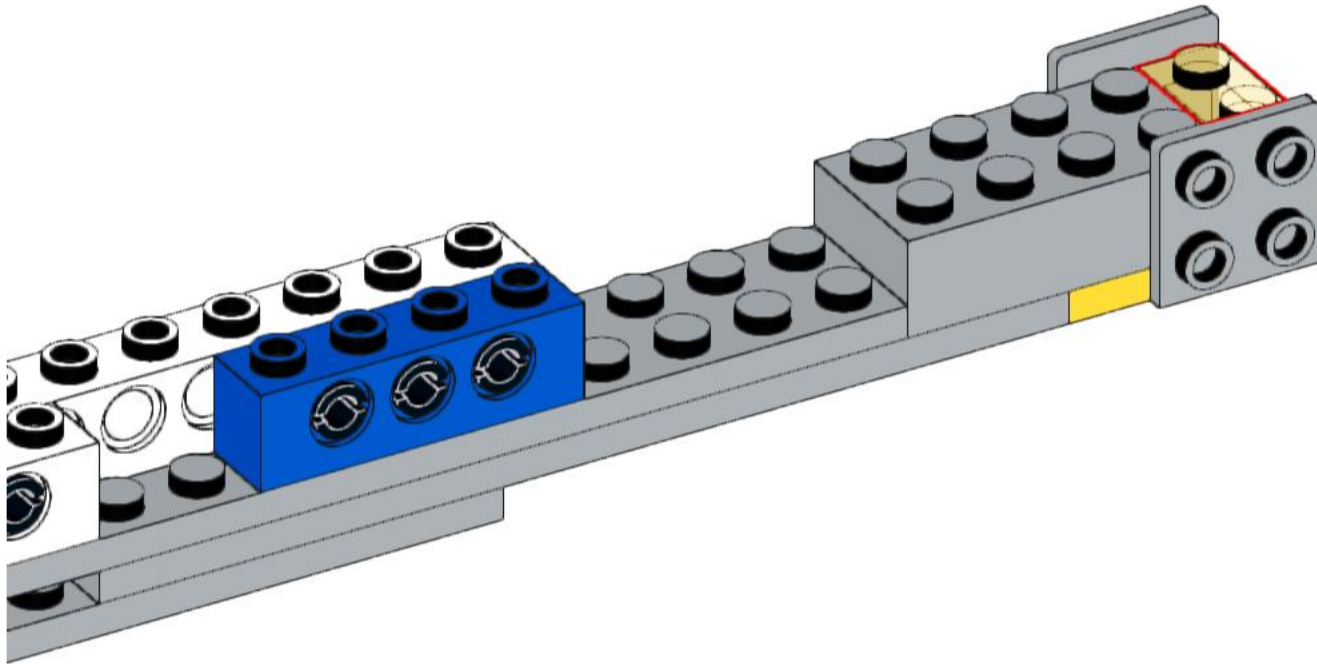
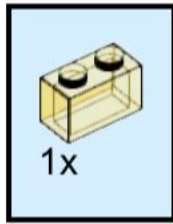

200

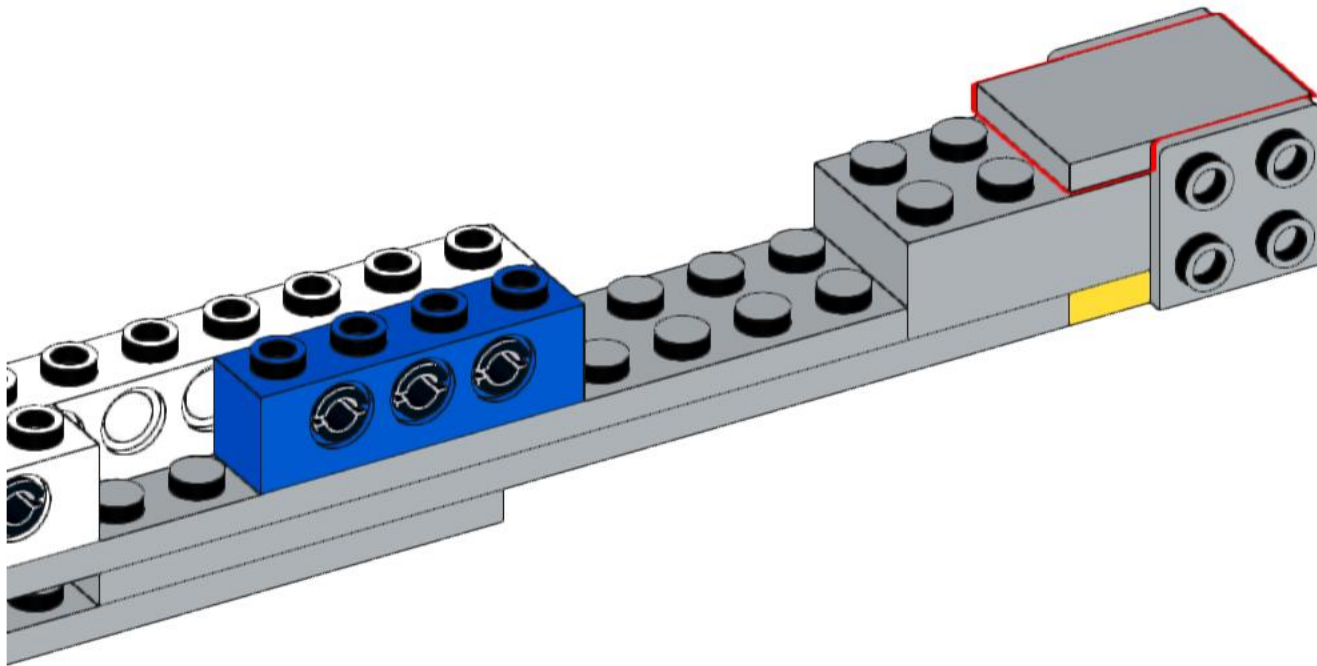
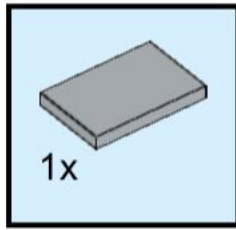

201

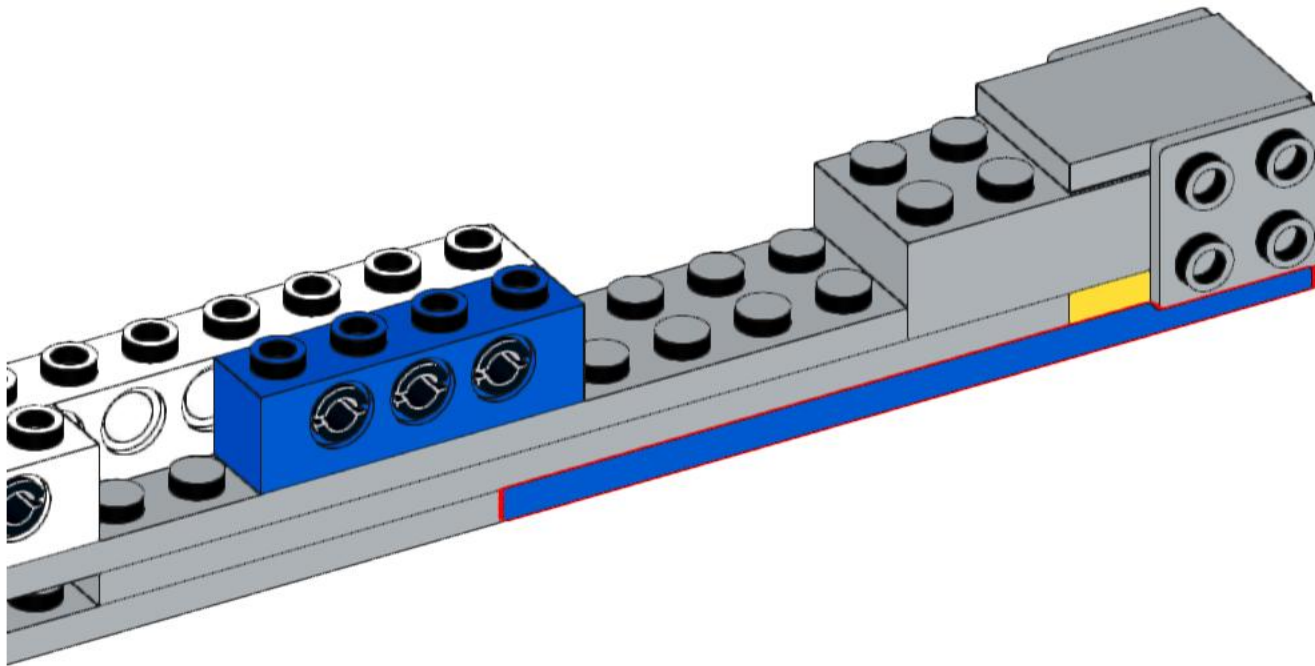
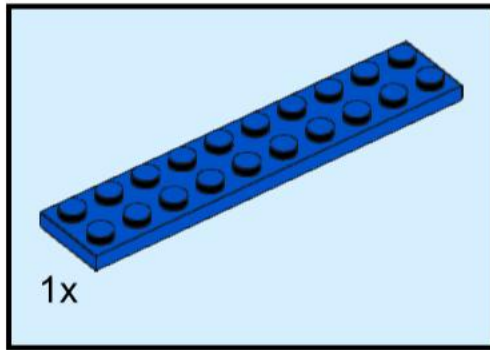

202

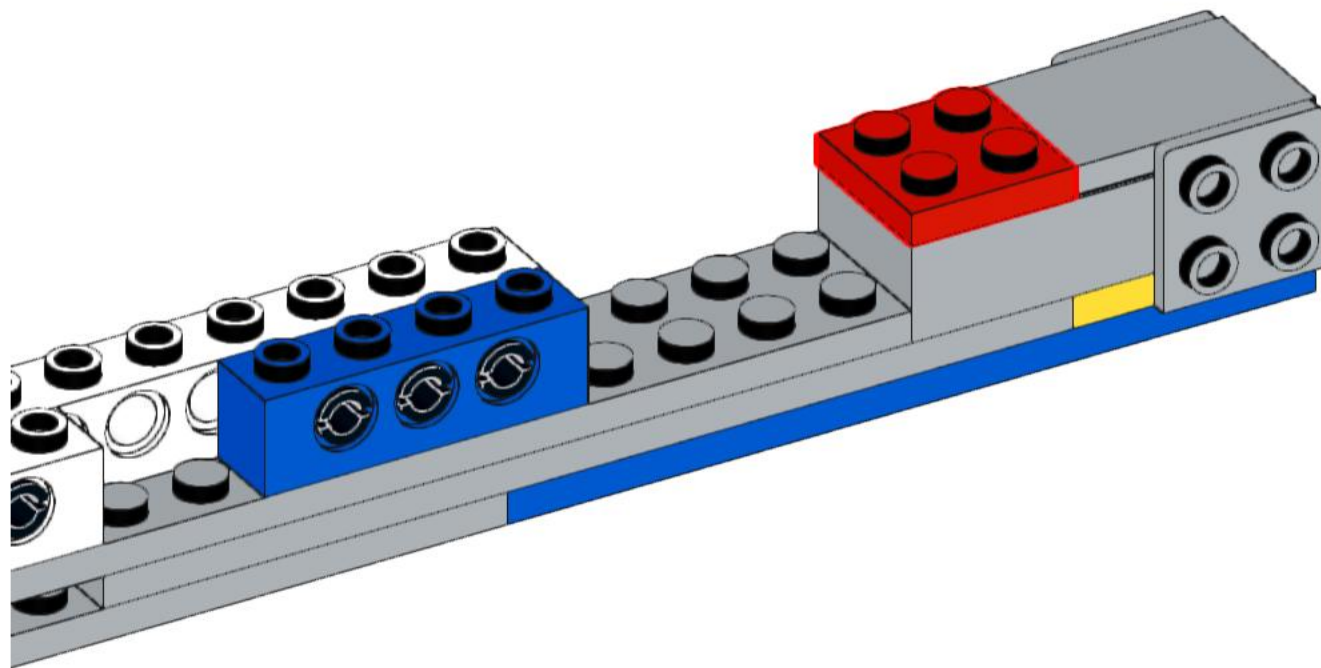
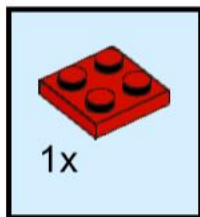

203

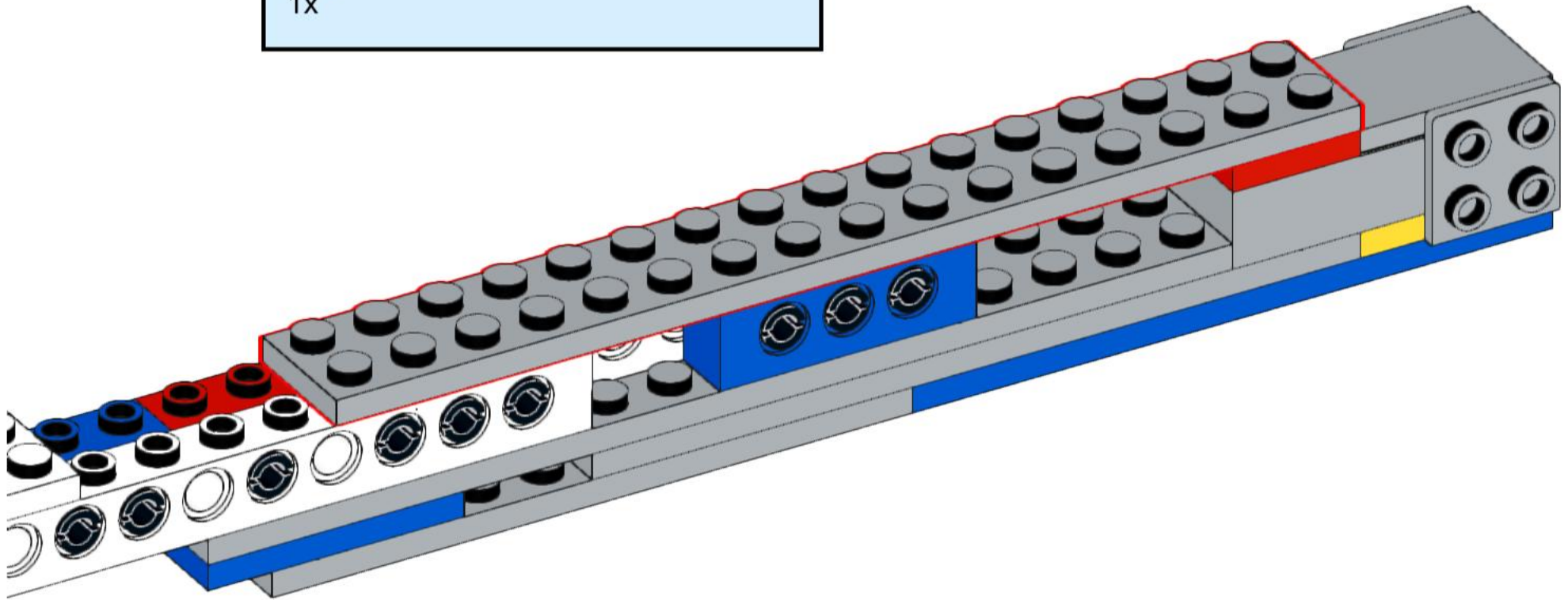
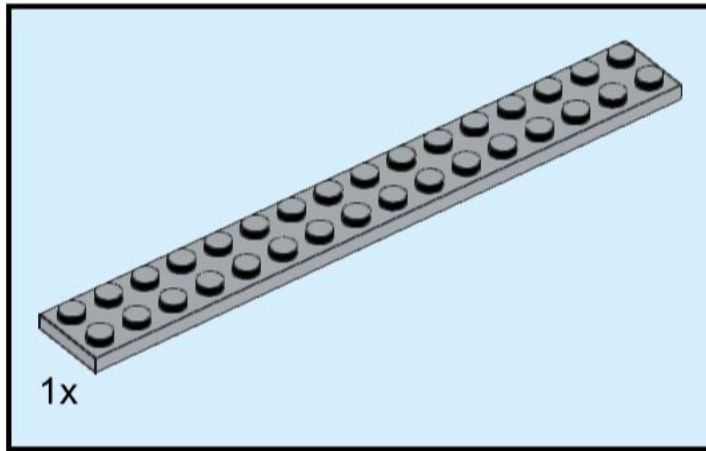

204

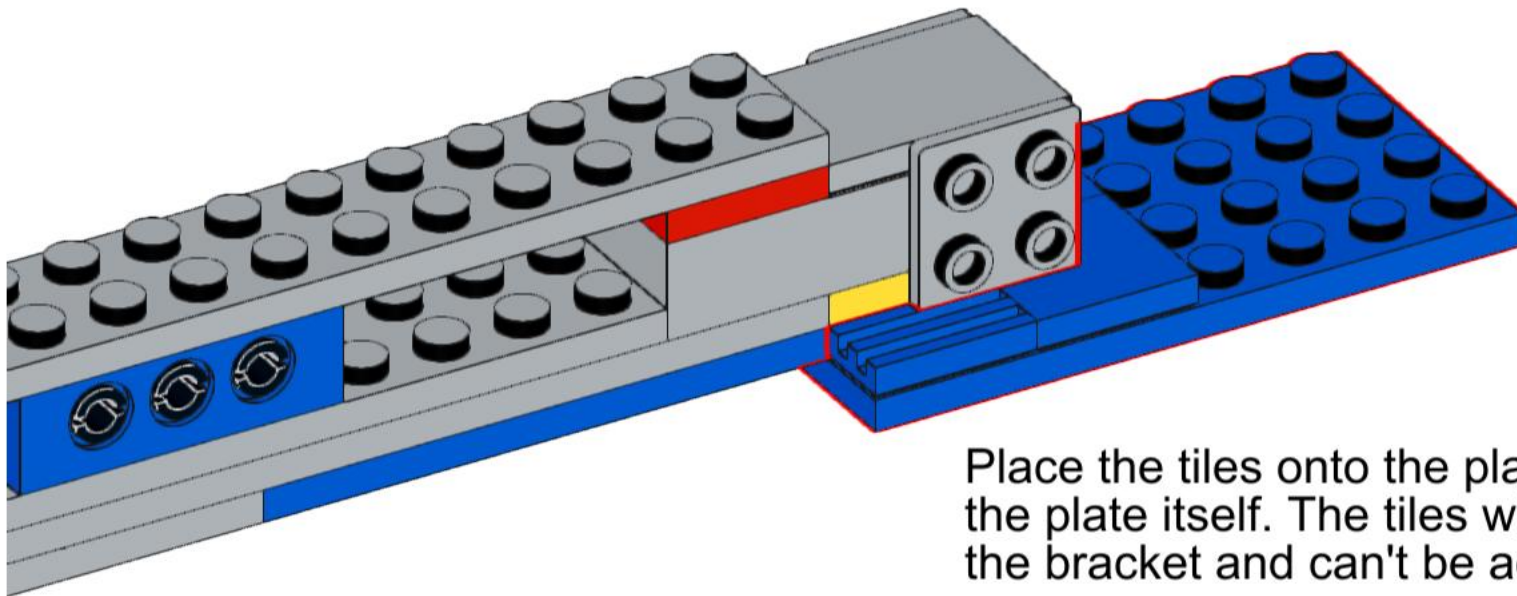
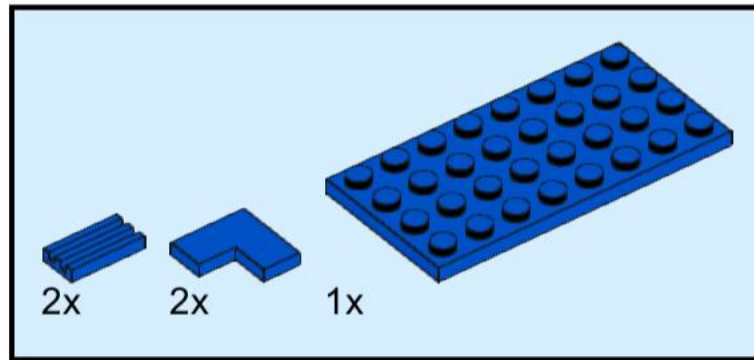

Place the tiles onto the plate before attaching the plate itself. The tiles will fit snugly under the bracket and can't be added after.

205

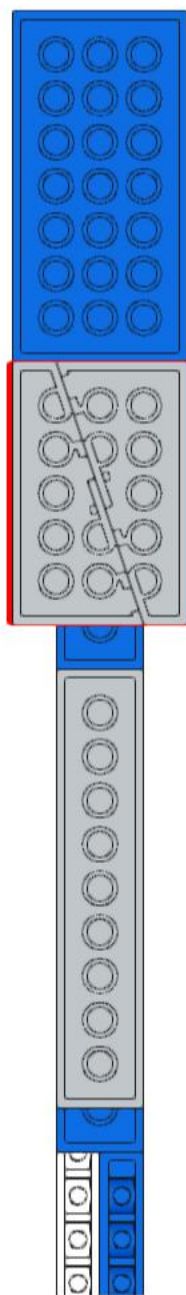
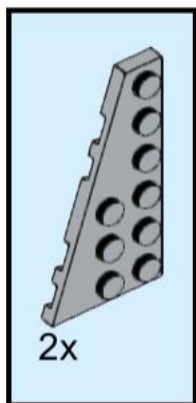

206

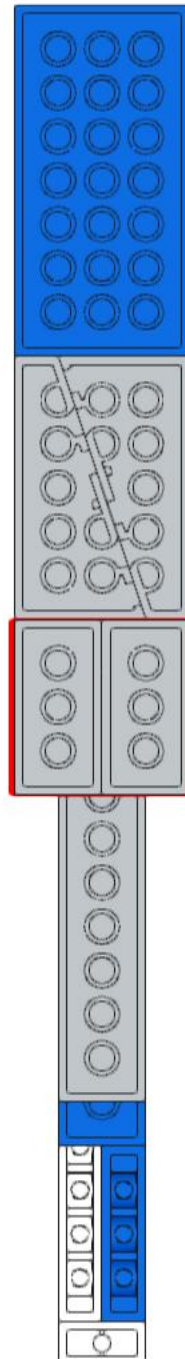
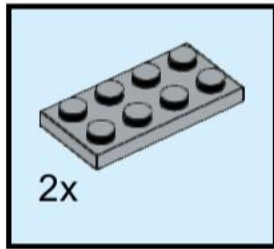

208

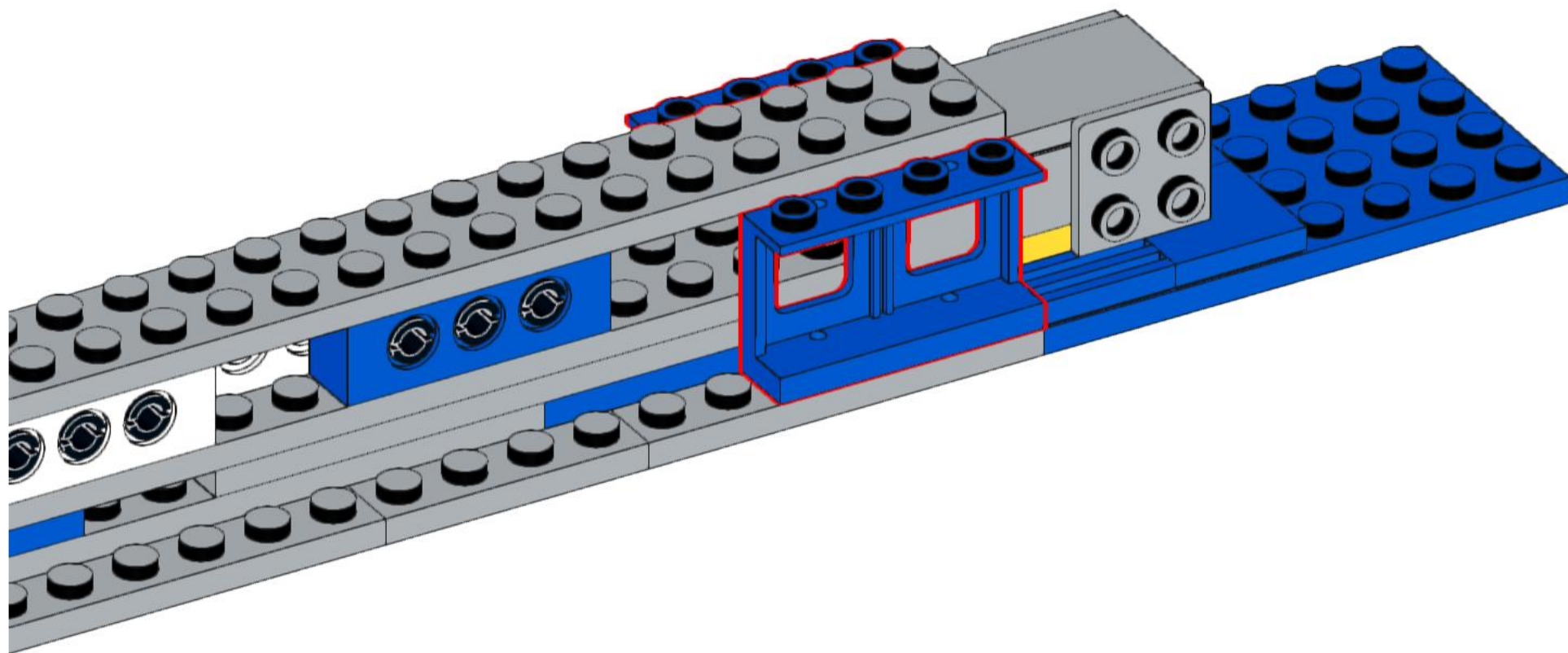
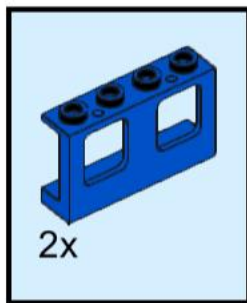

209

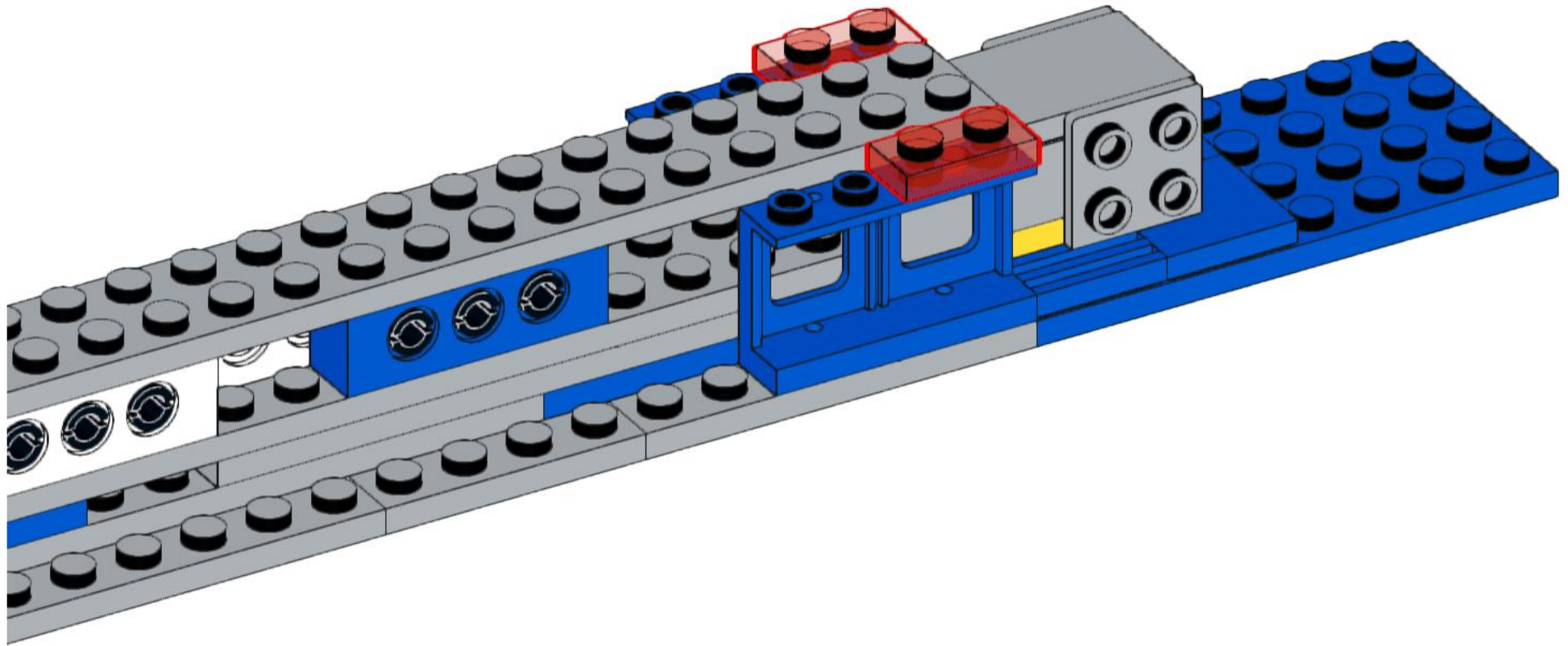
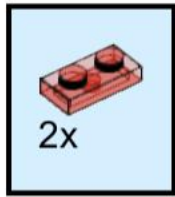

210

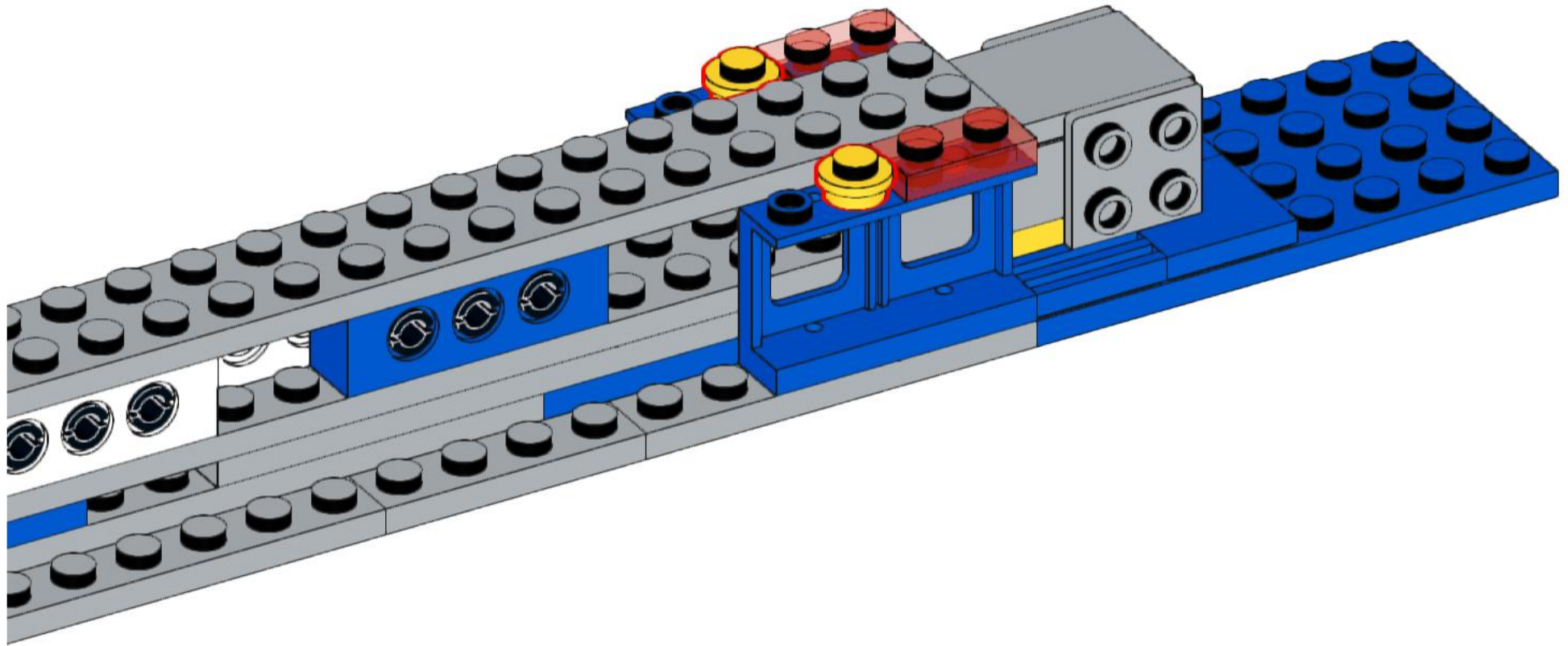

211

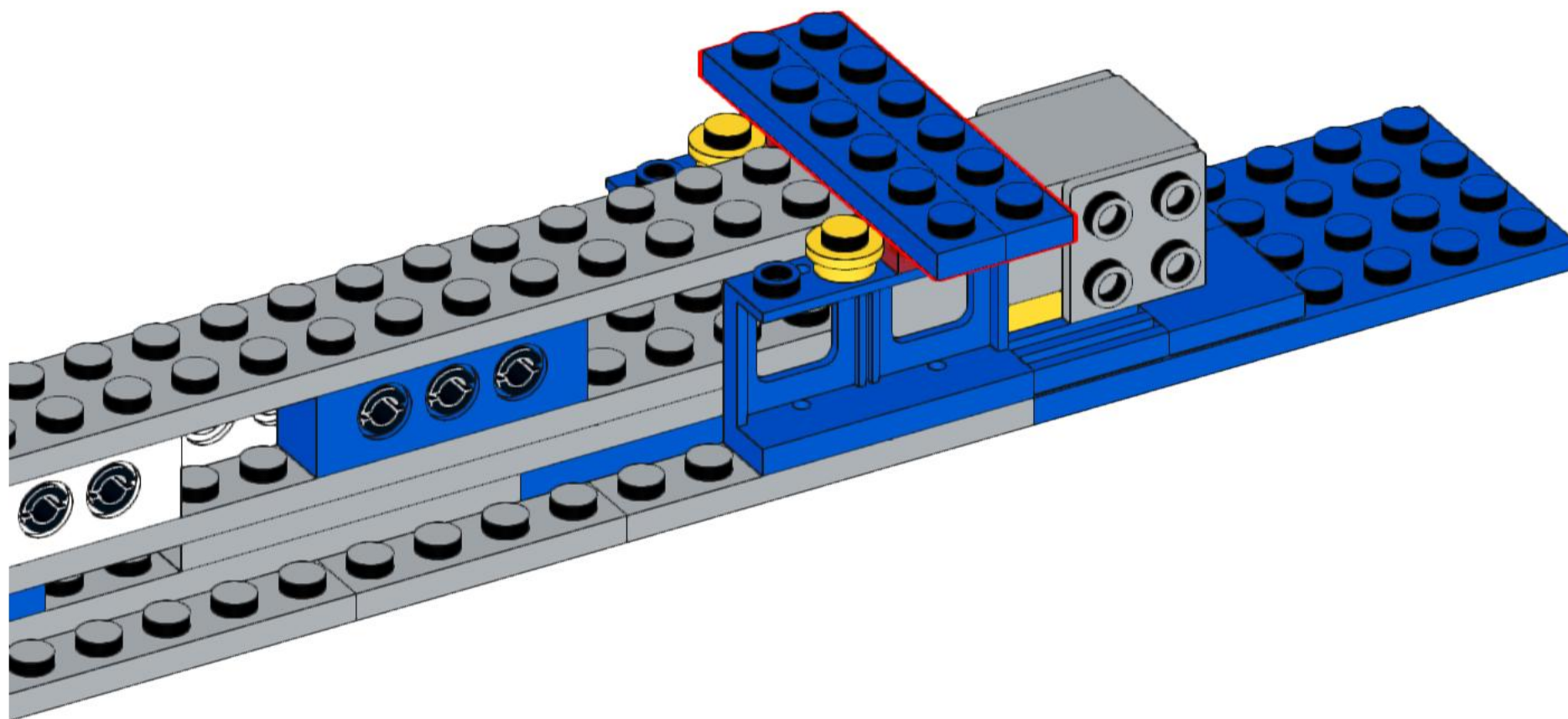
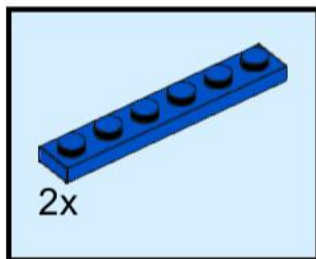

212

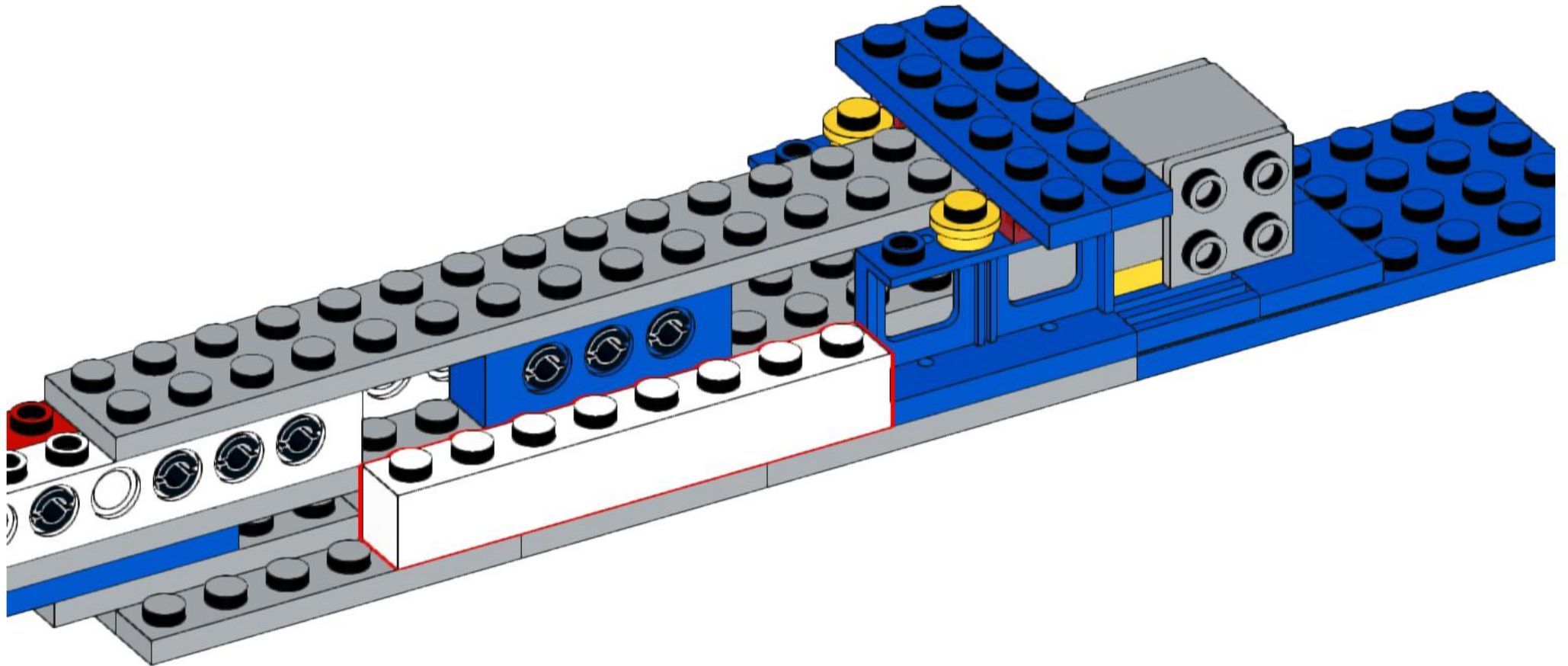
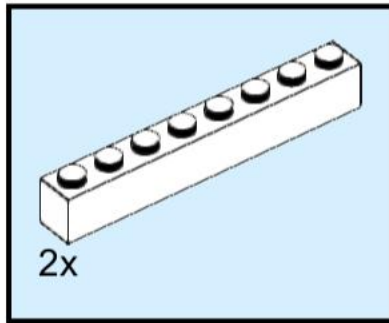

213

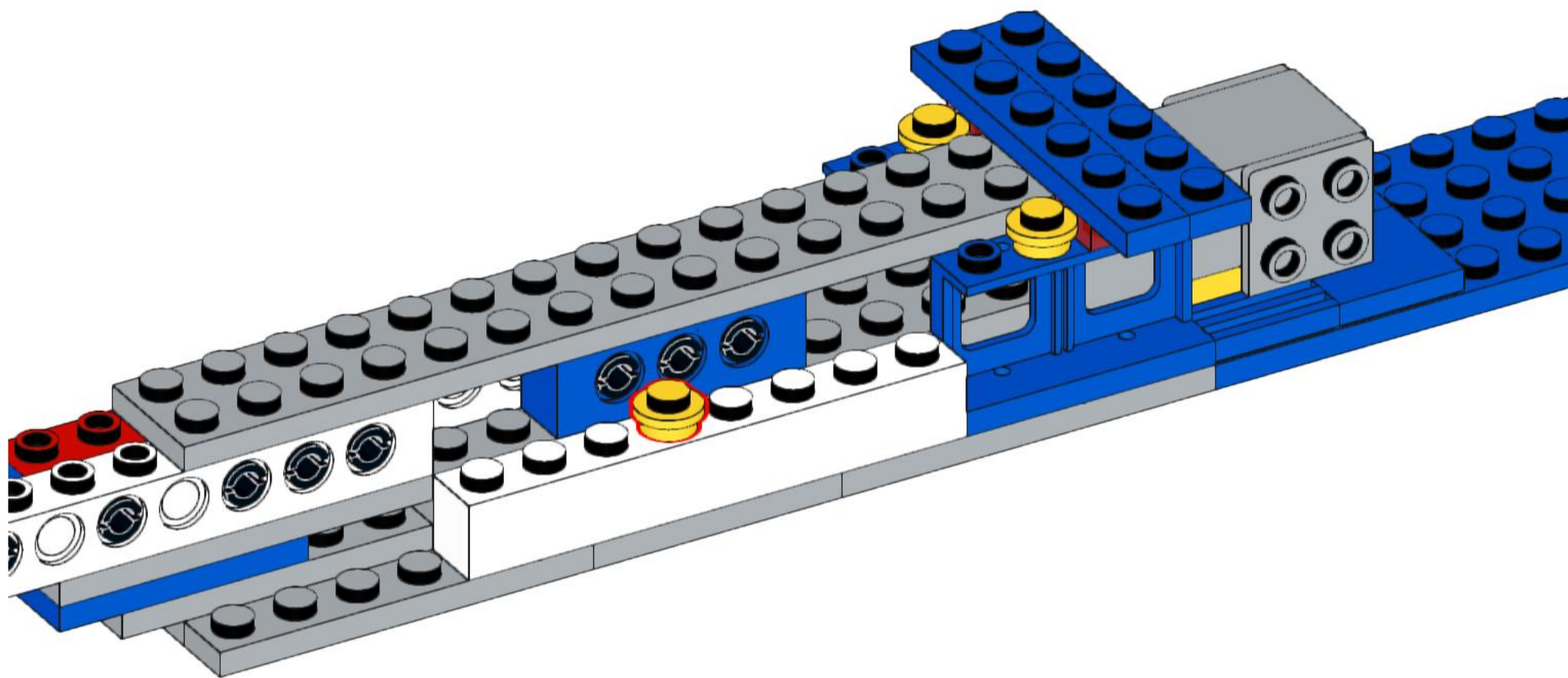

214

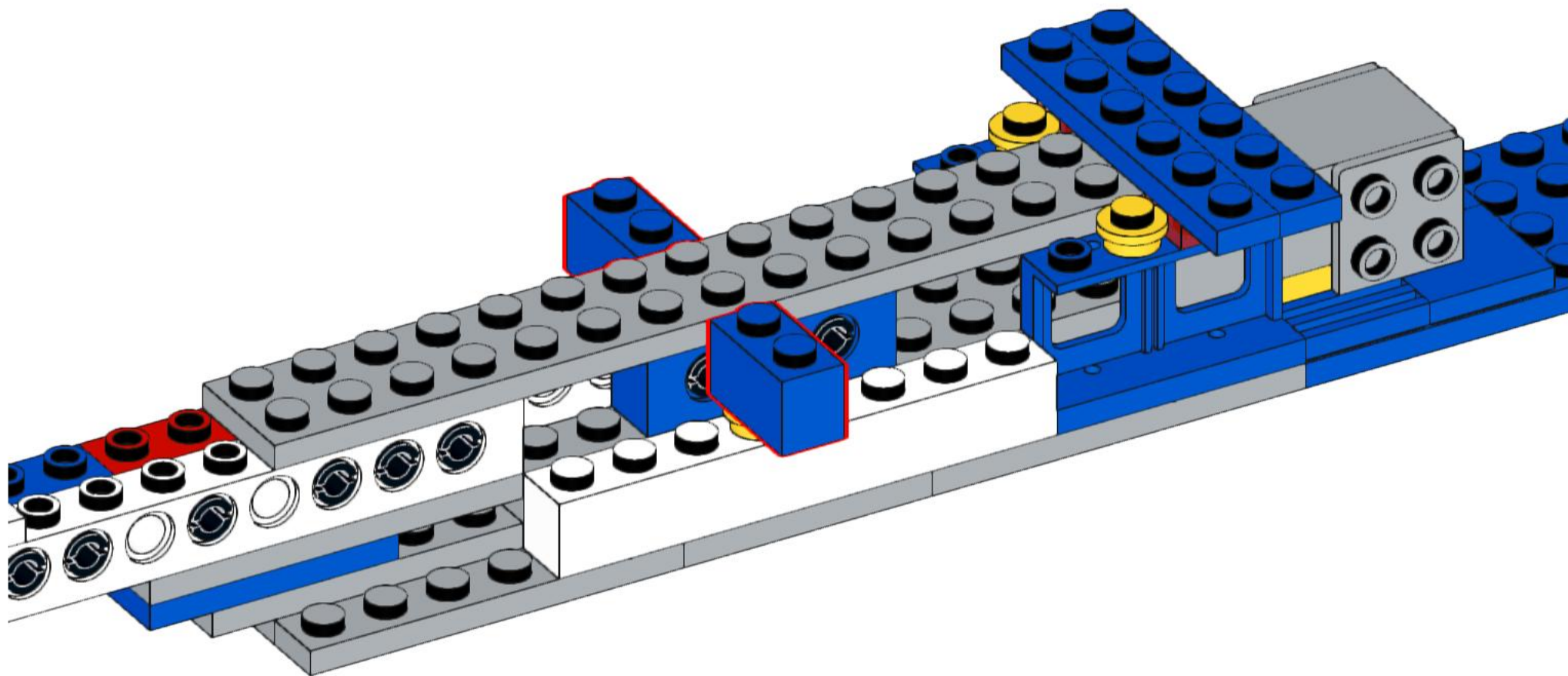
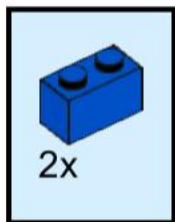

215

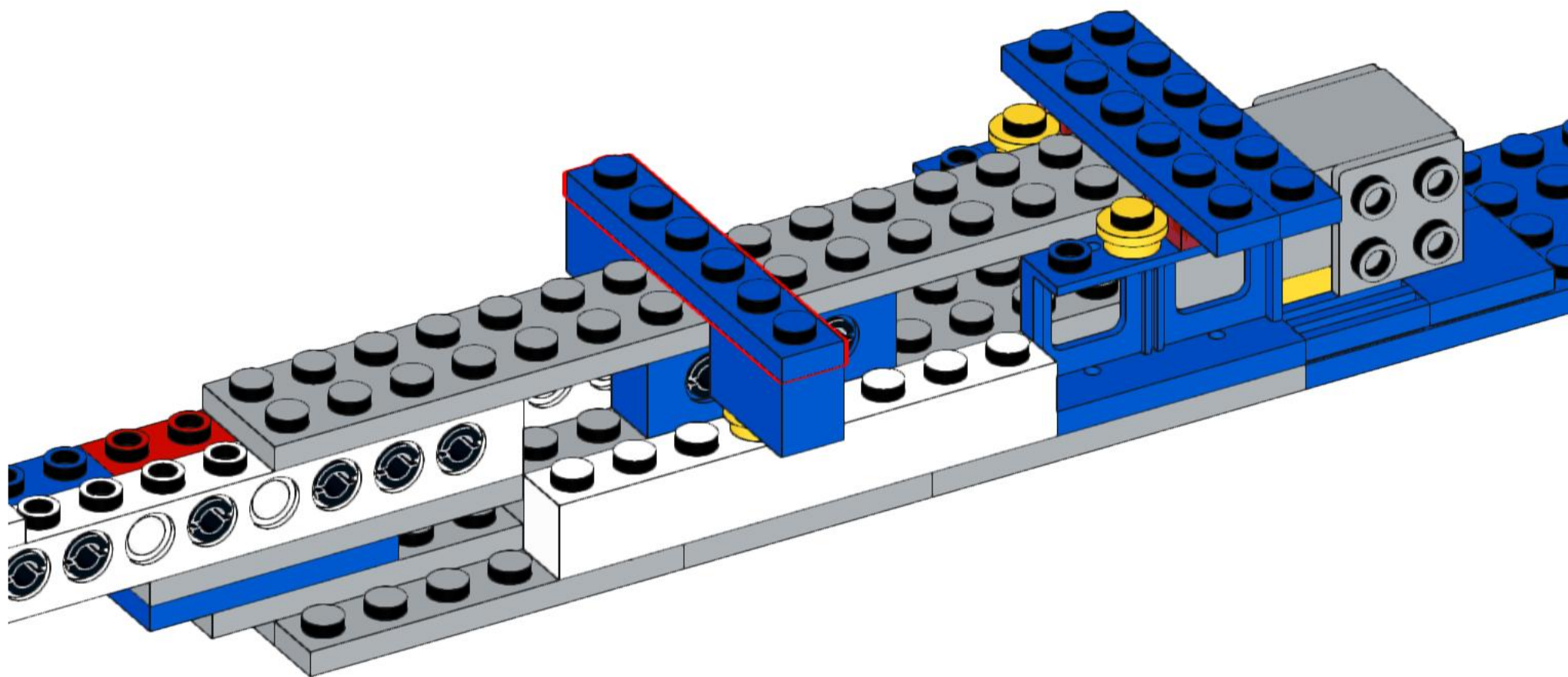
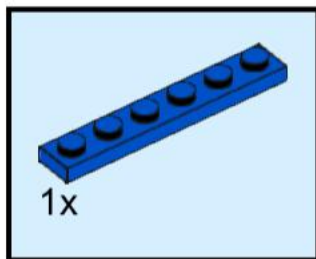

216

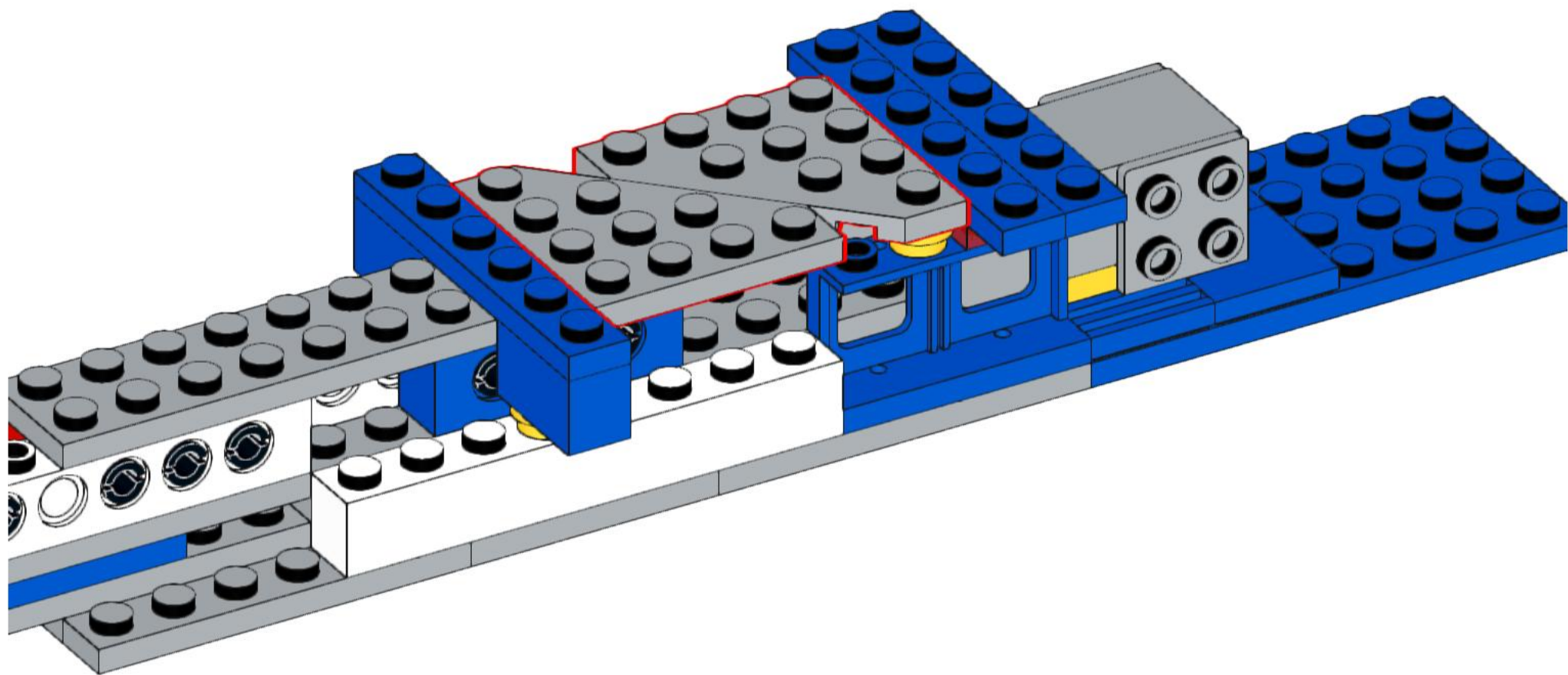
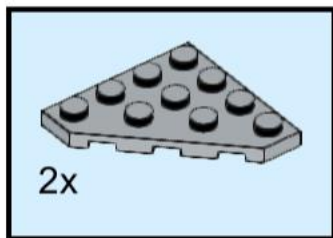

217

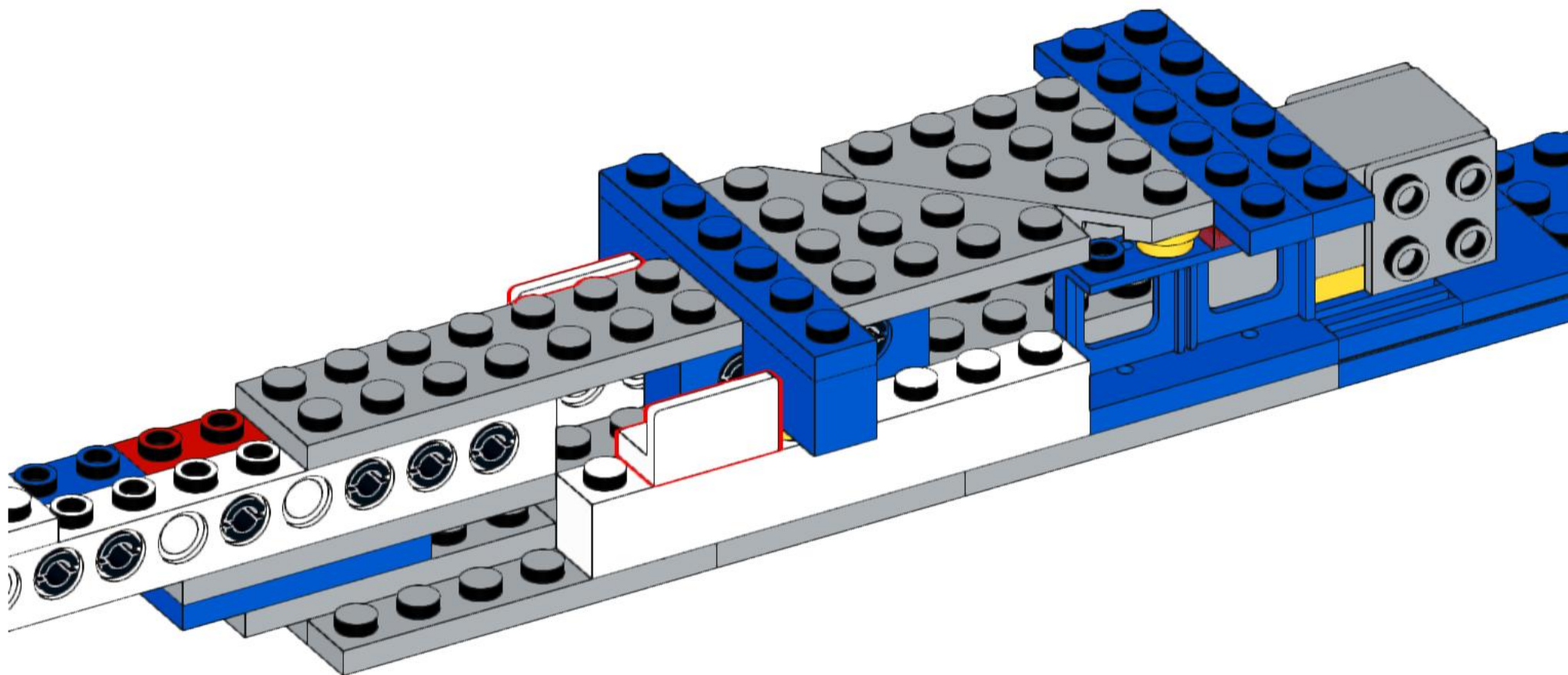
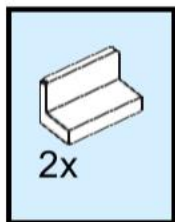

218

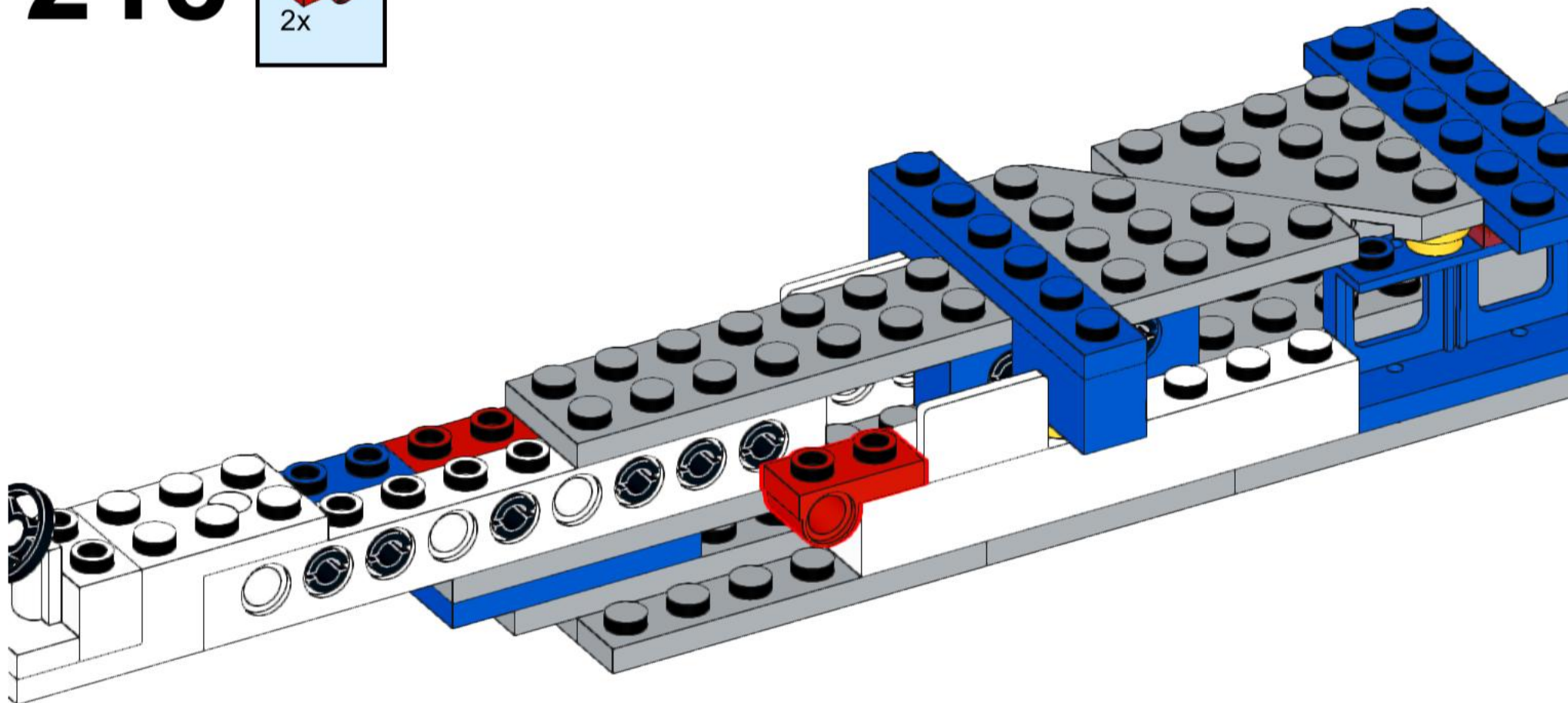
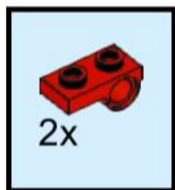

219

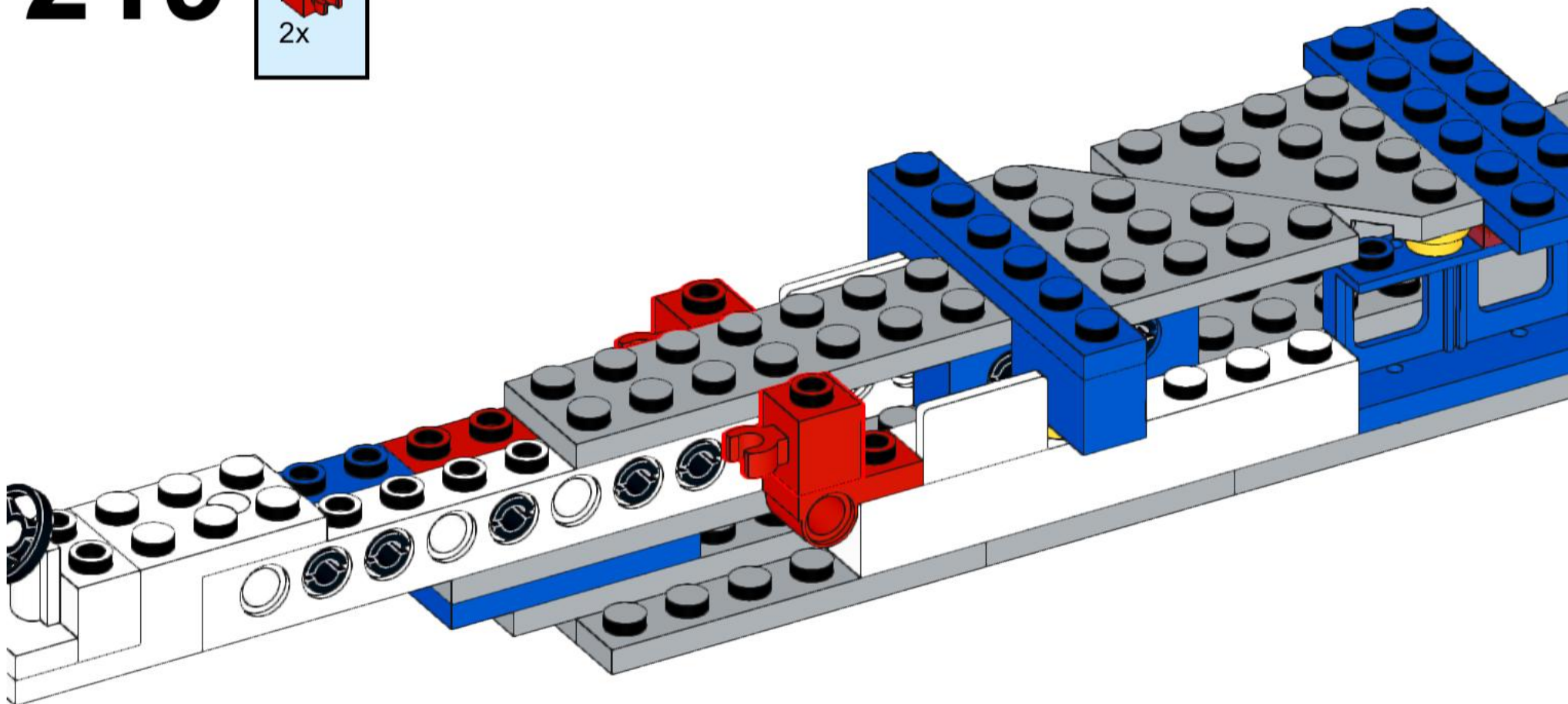
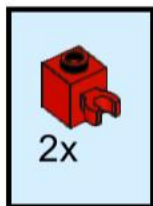

220

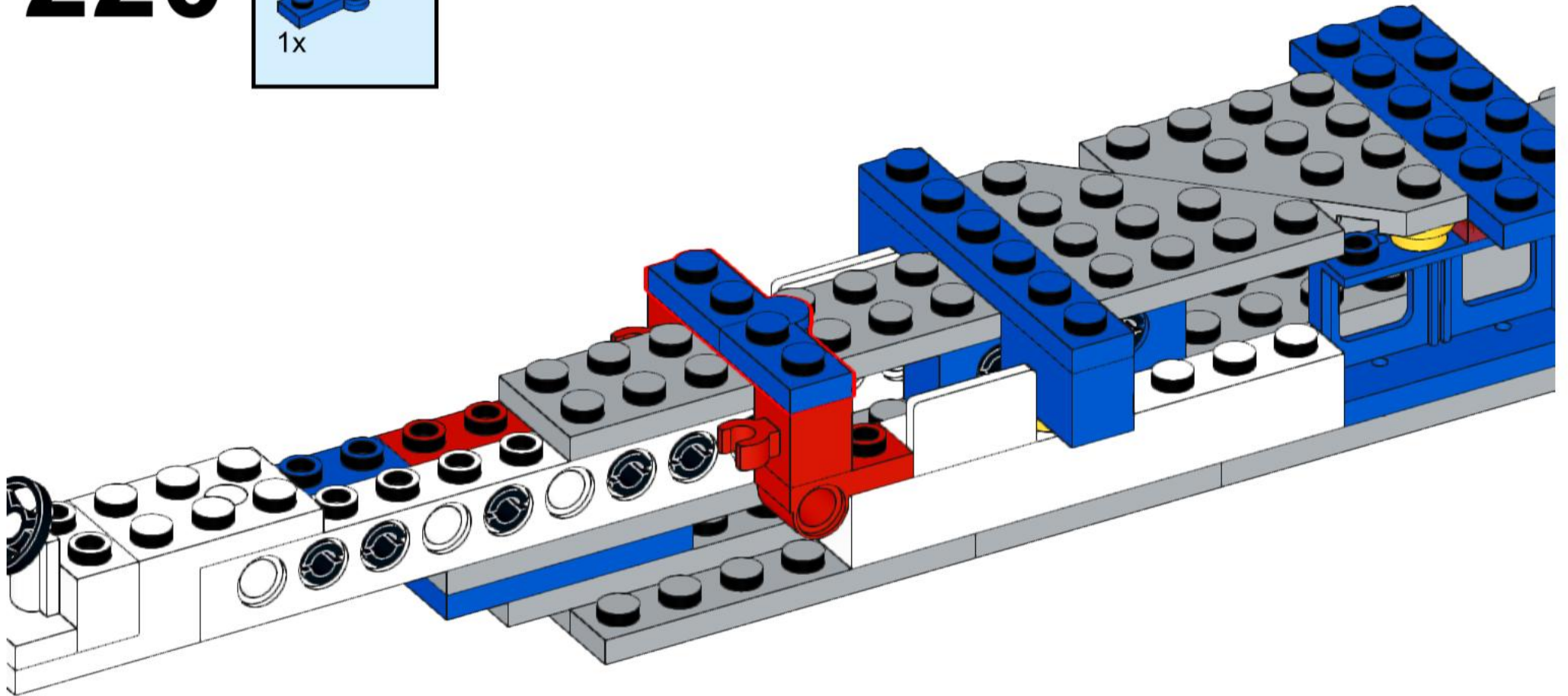
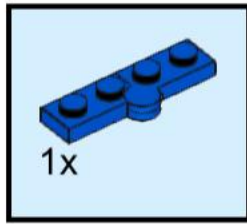

221

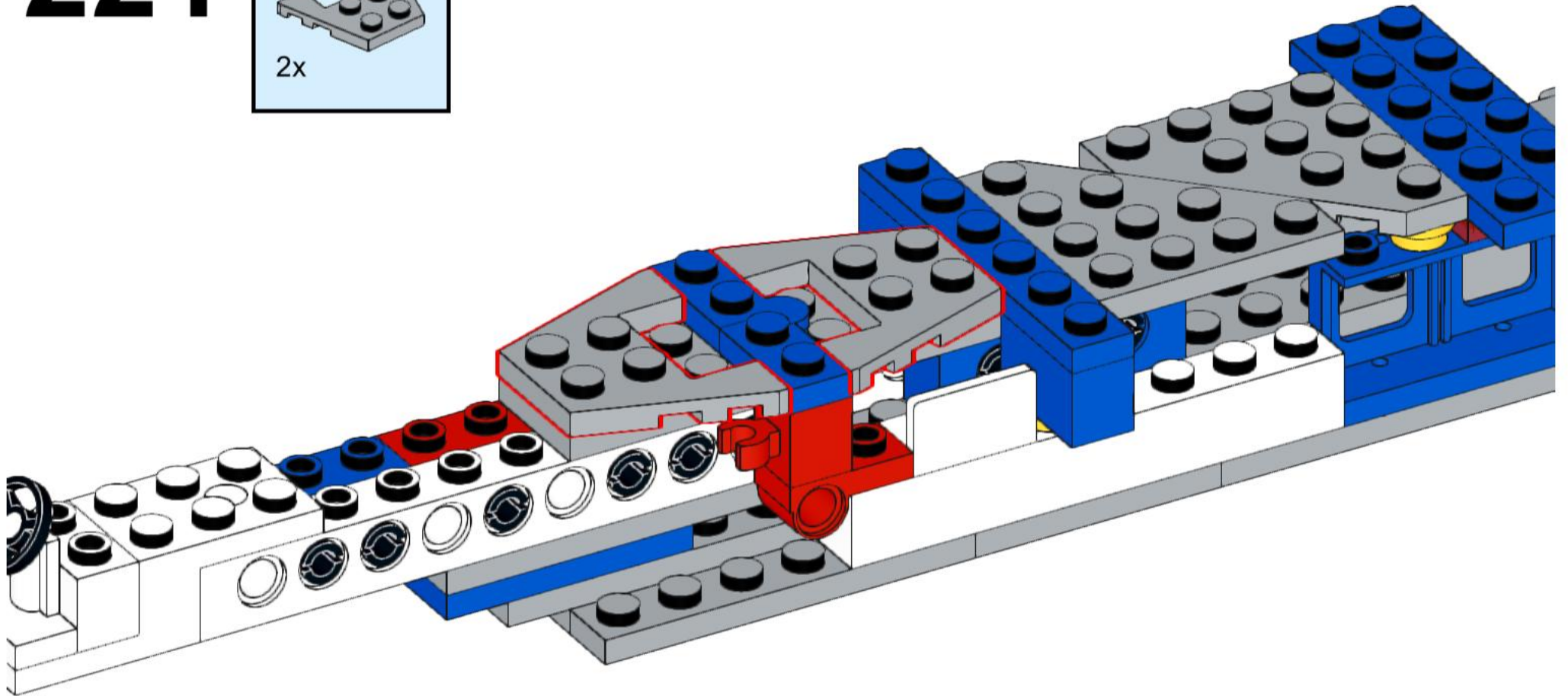
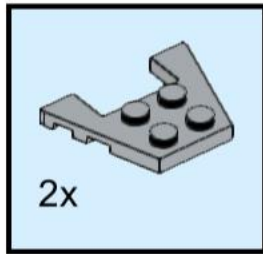

222

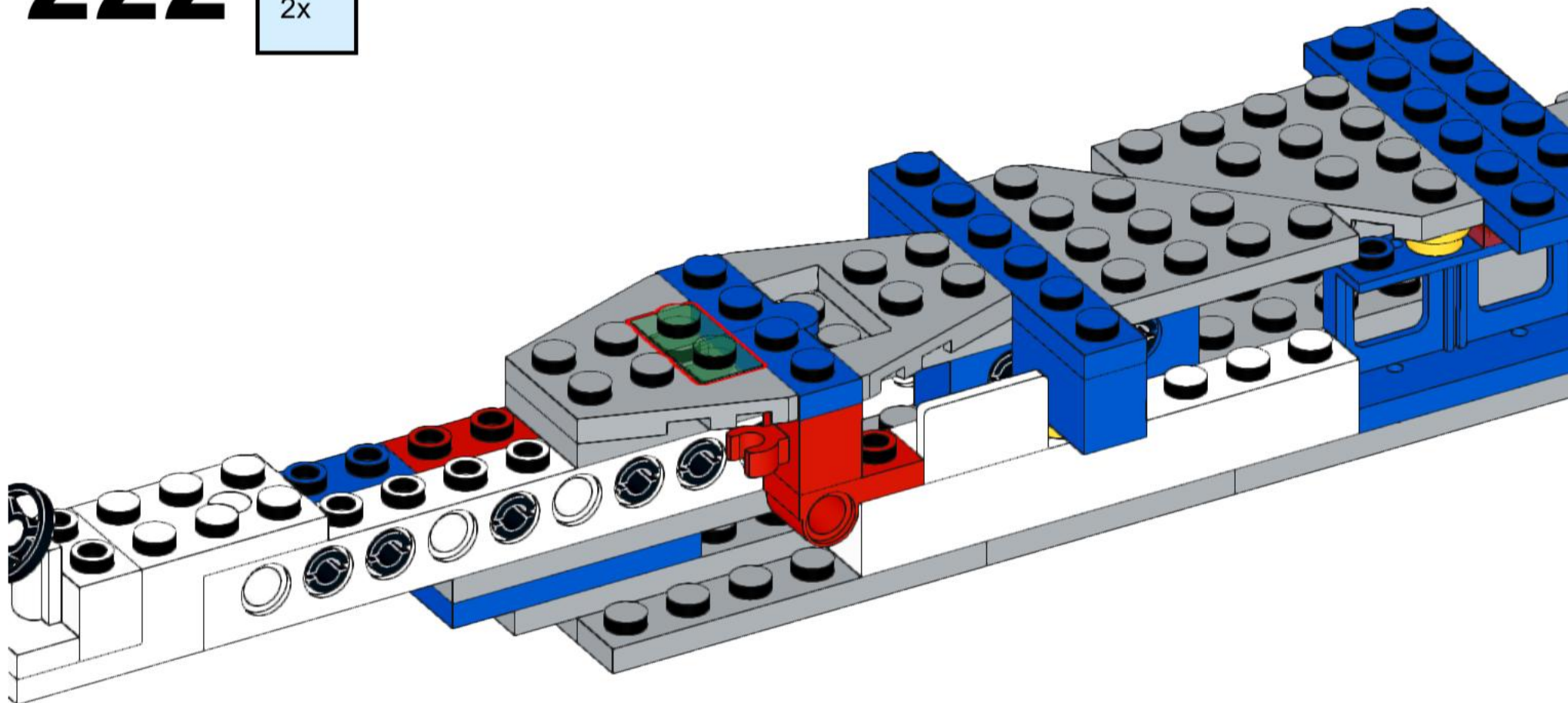
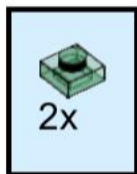

223

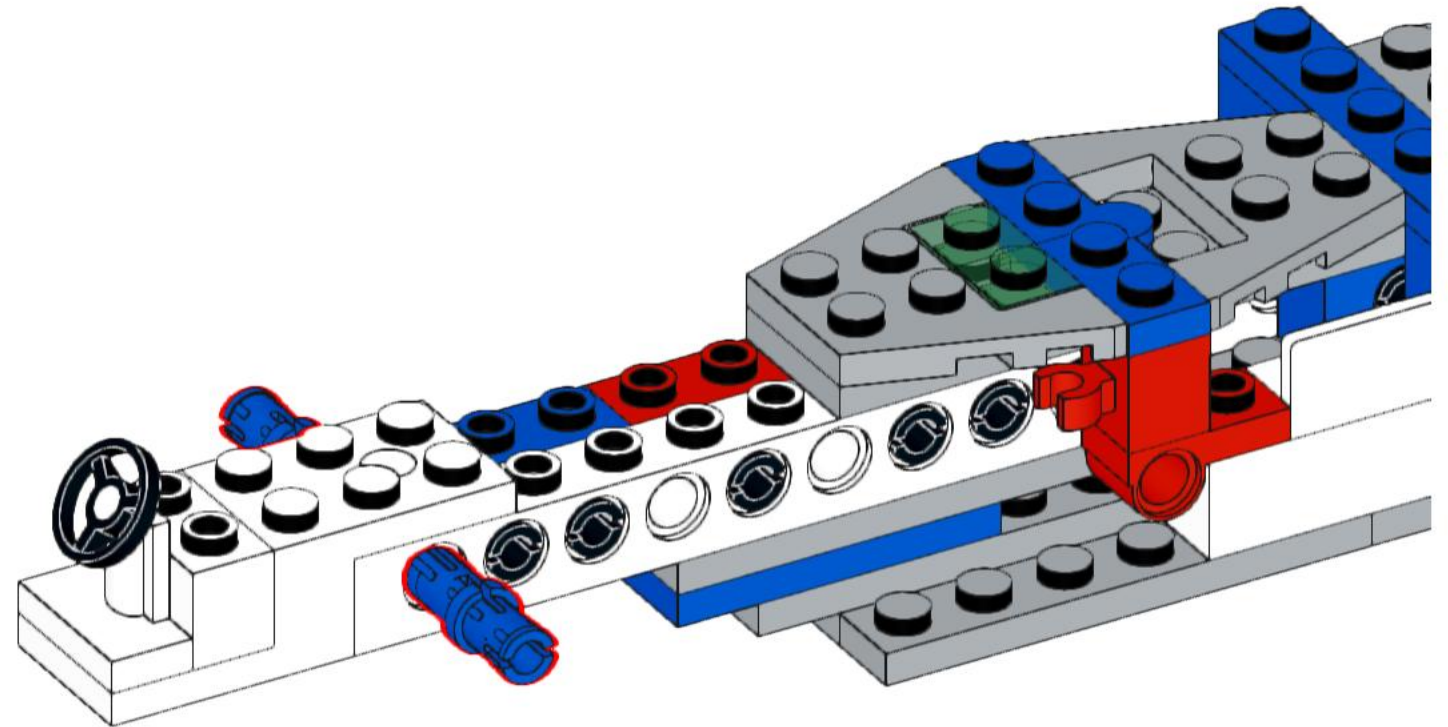
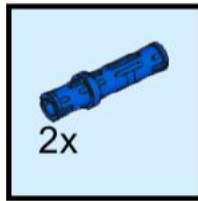

224

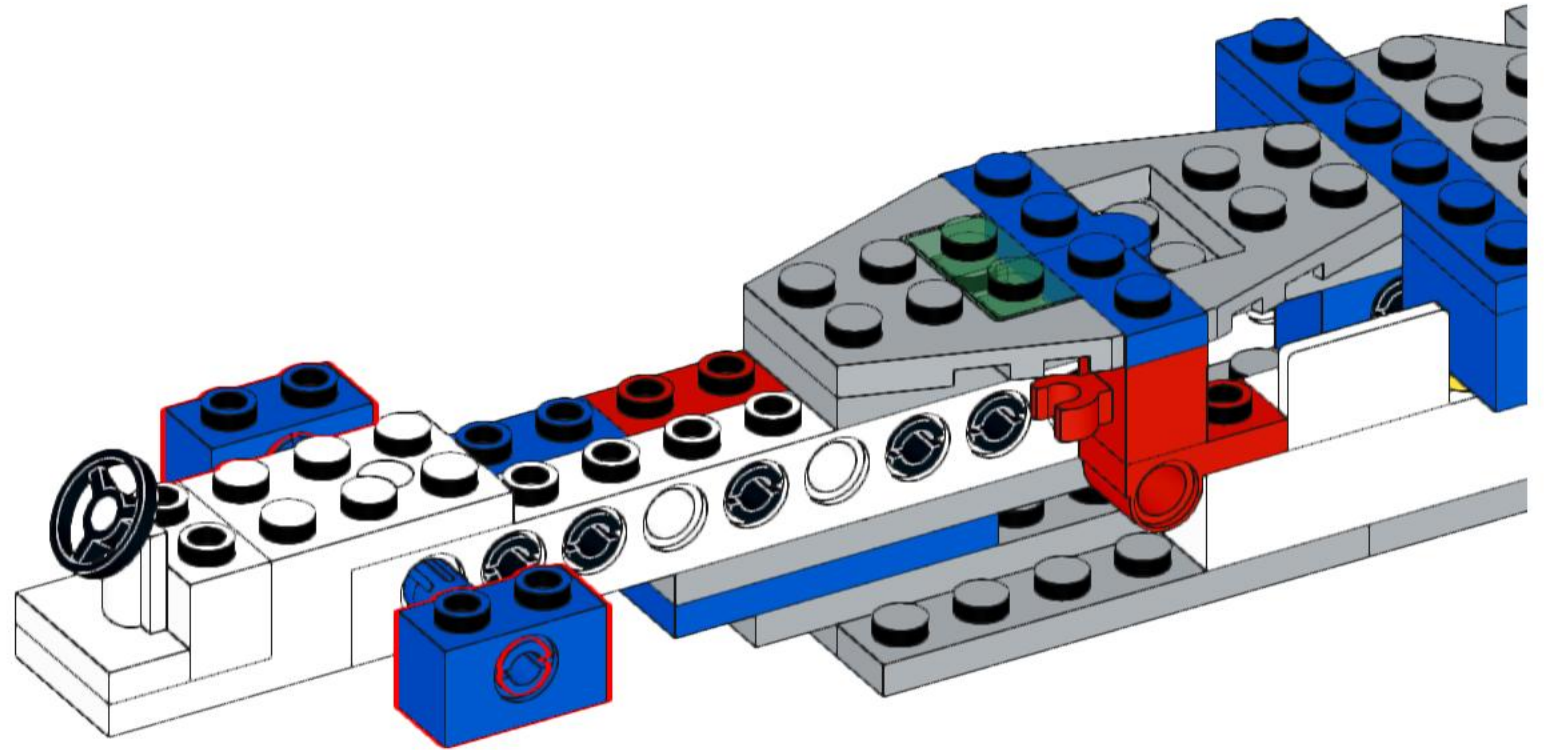
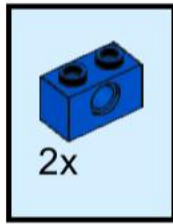

225

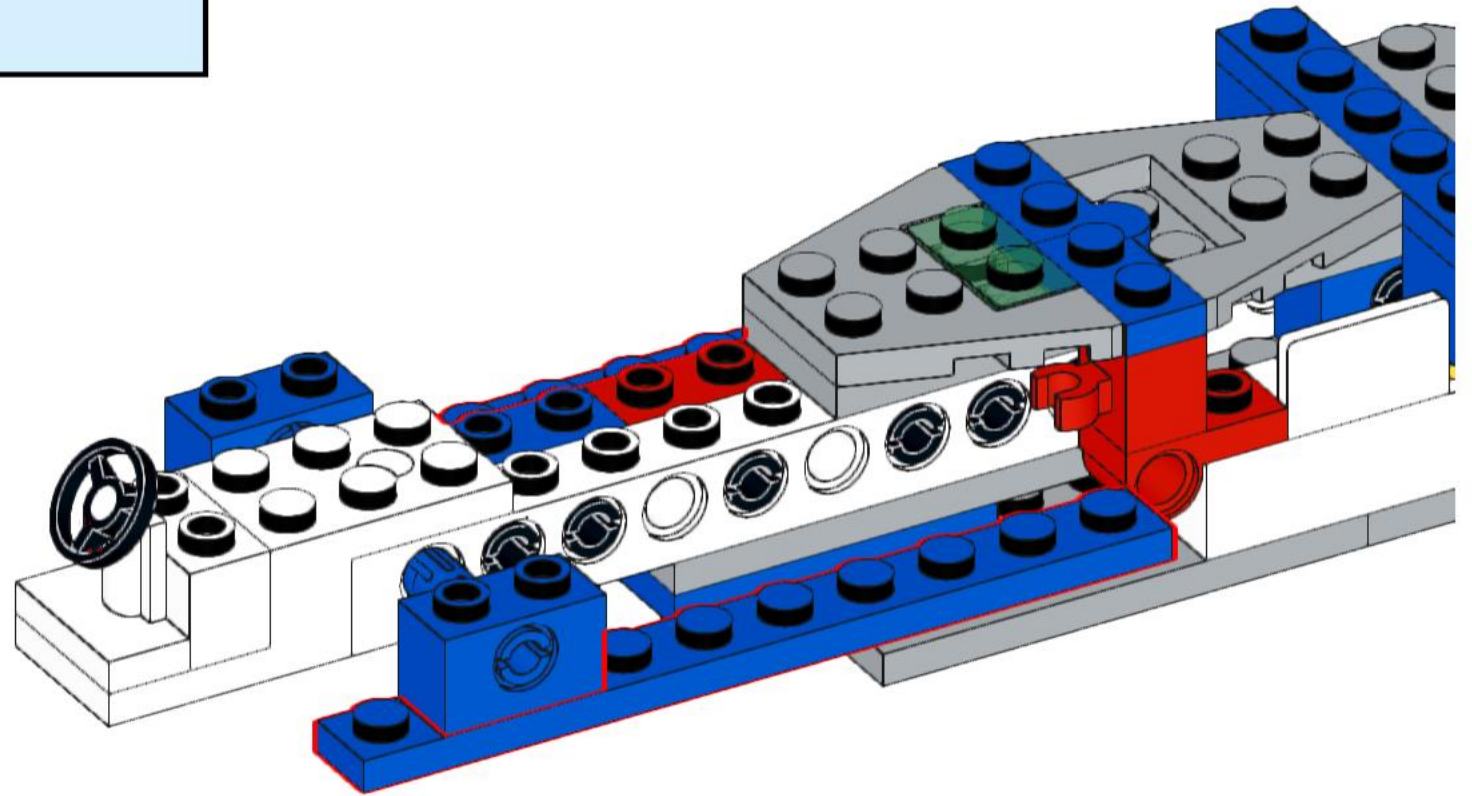
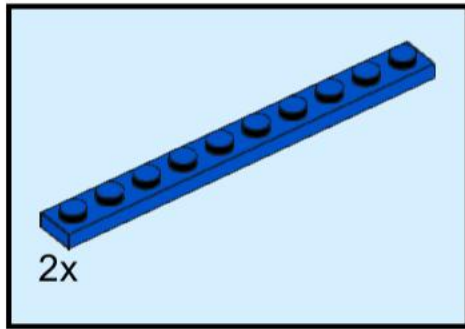

227

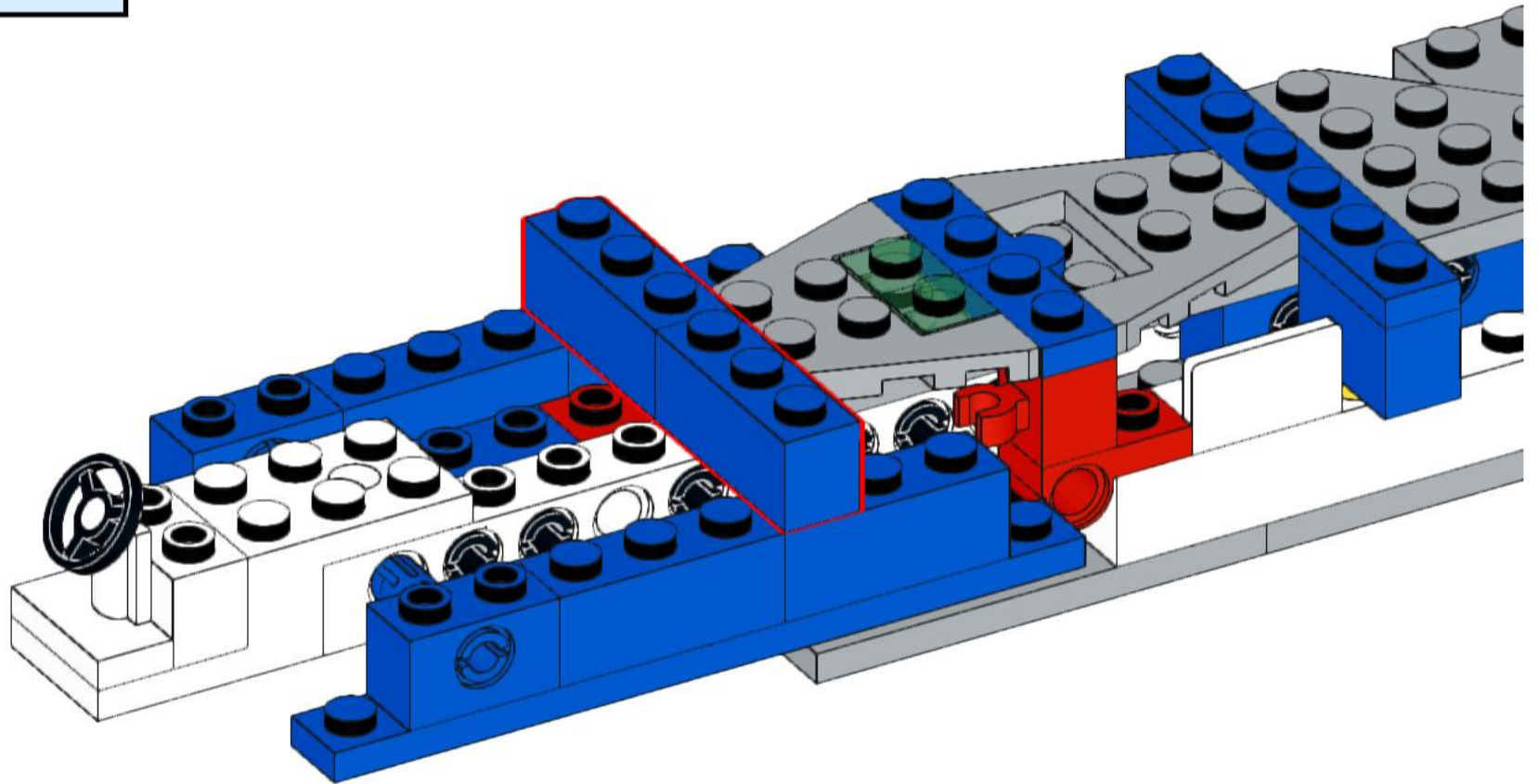
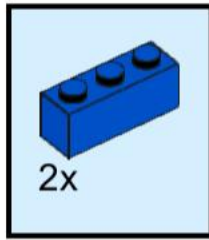

228

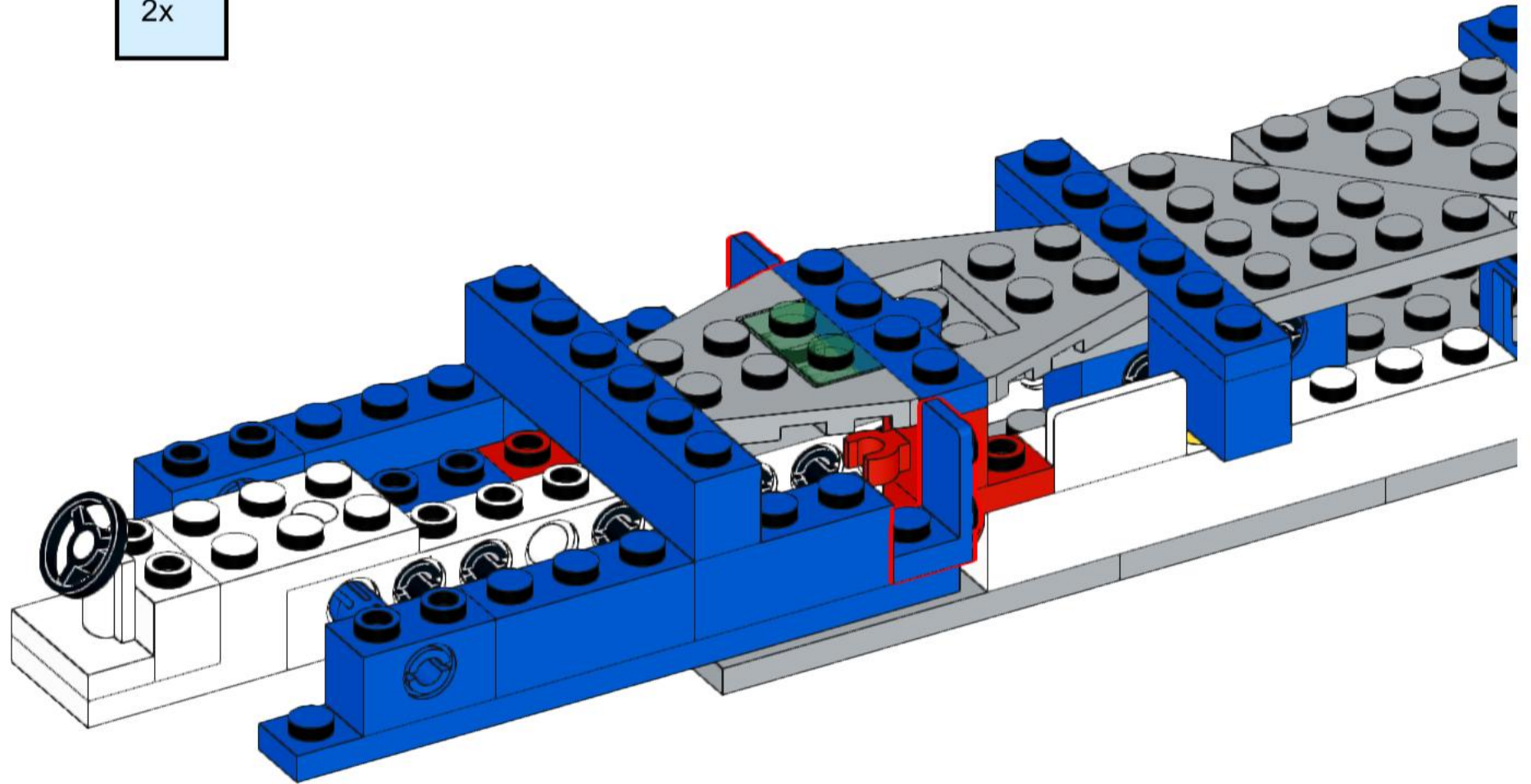
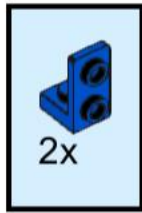

229

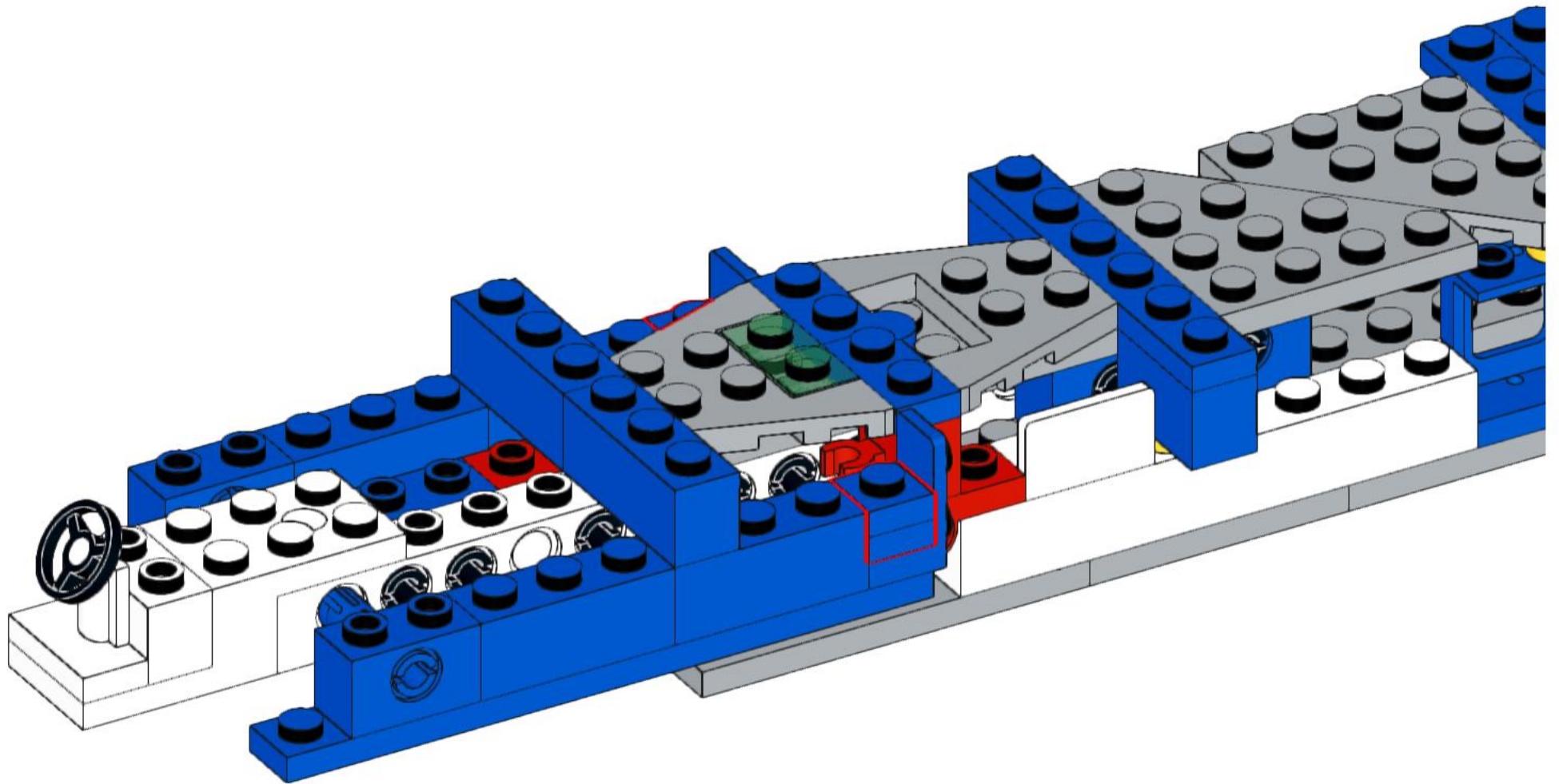
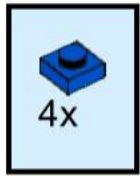

230

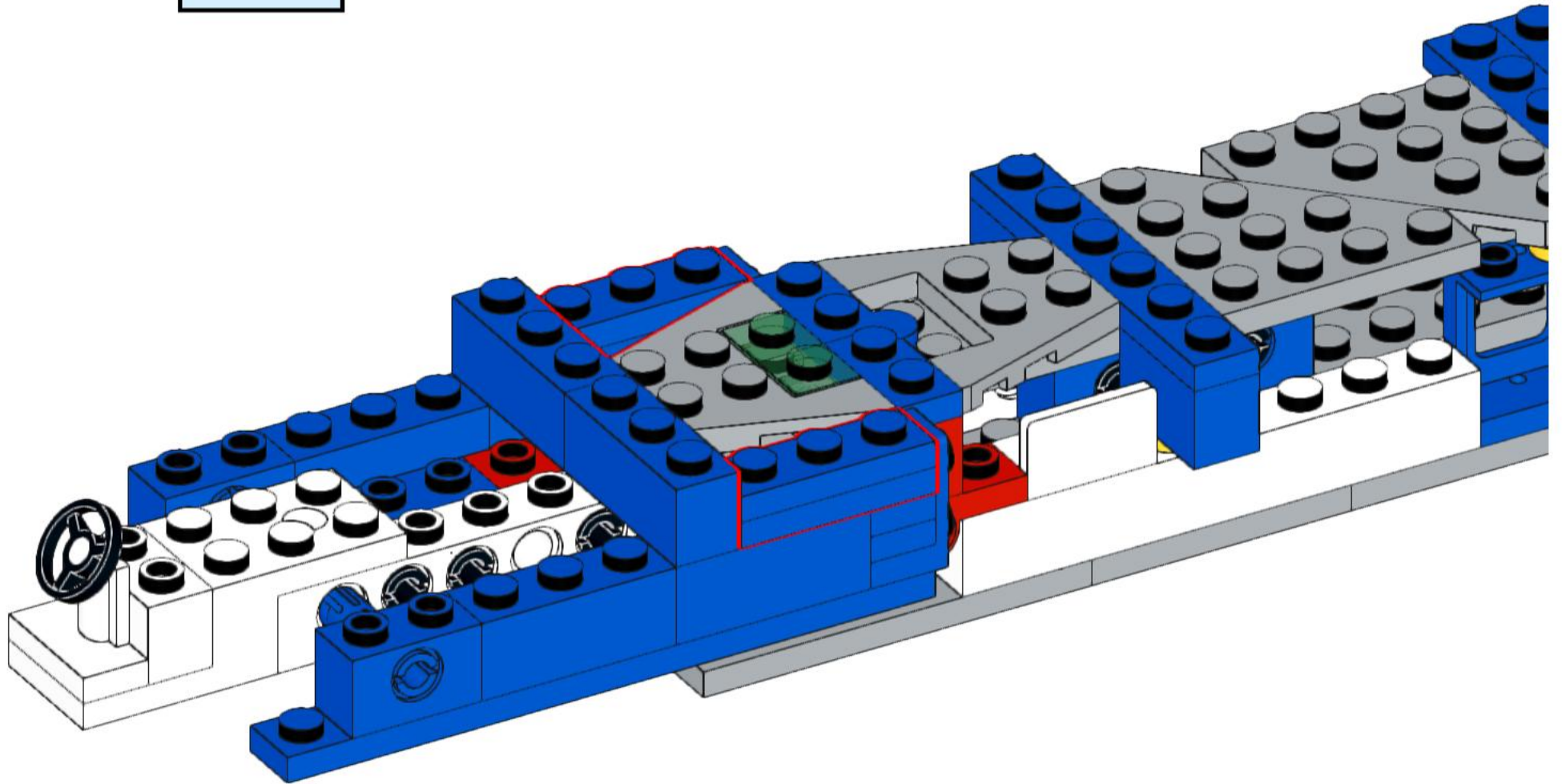
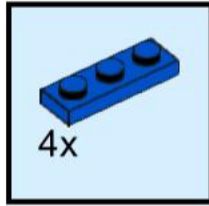

231

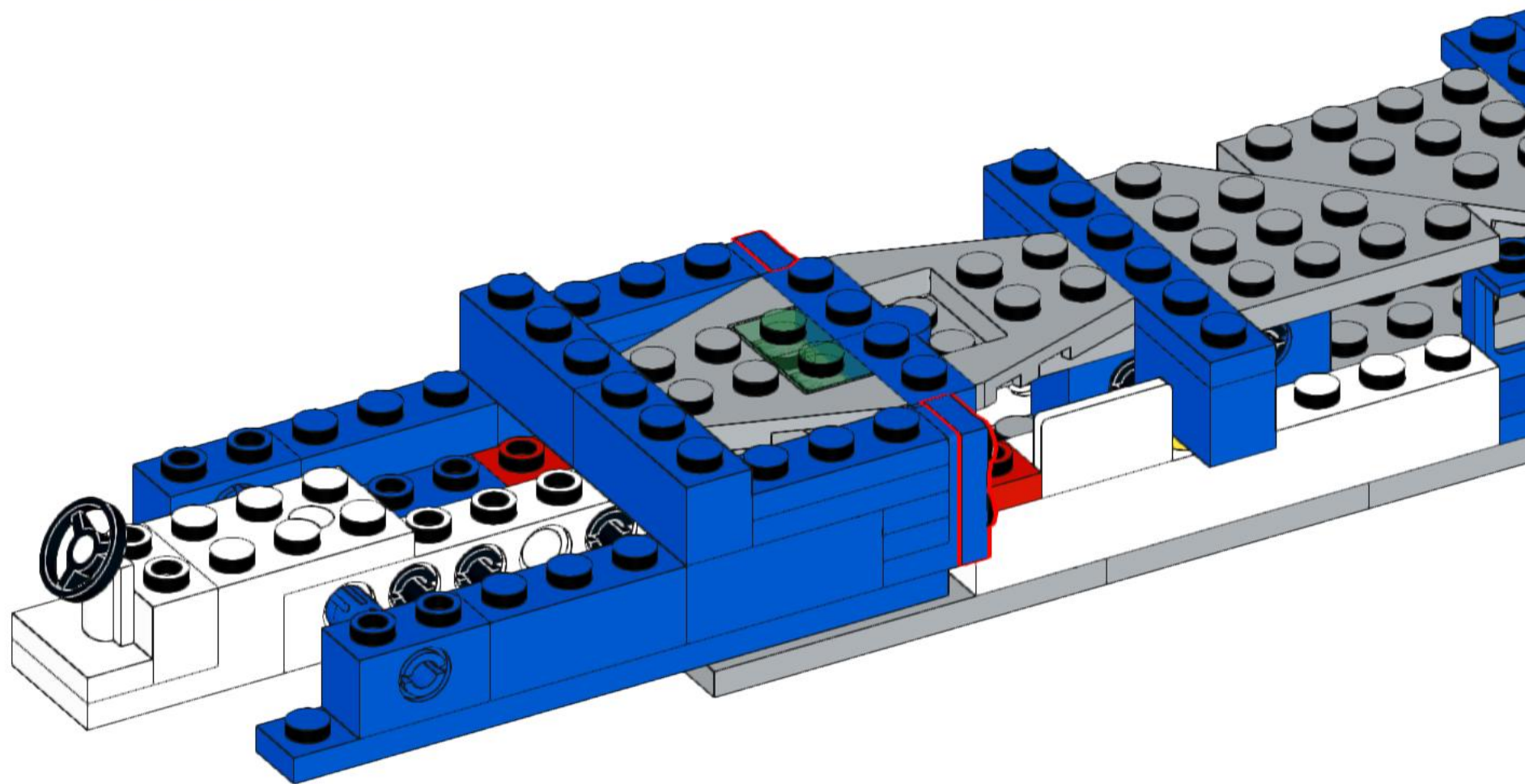
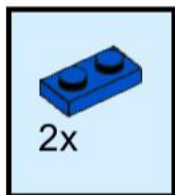

232

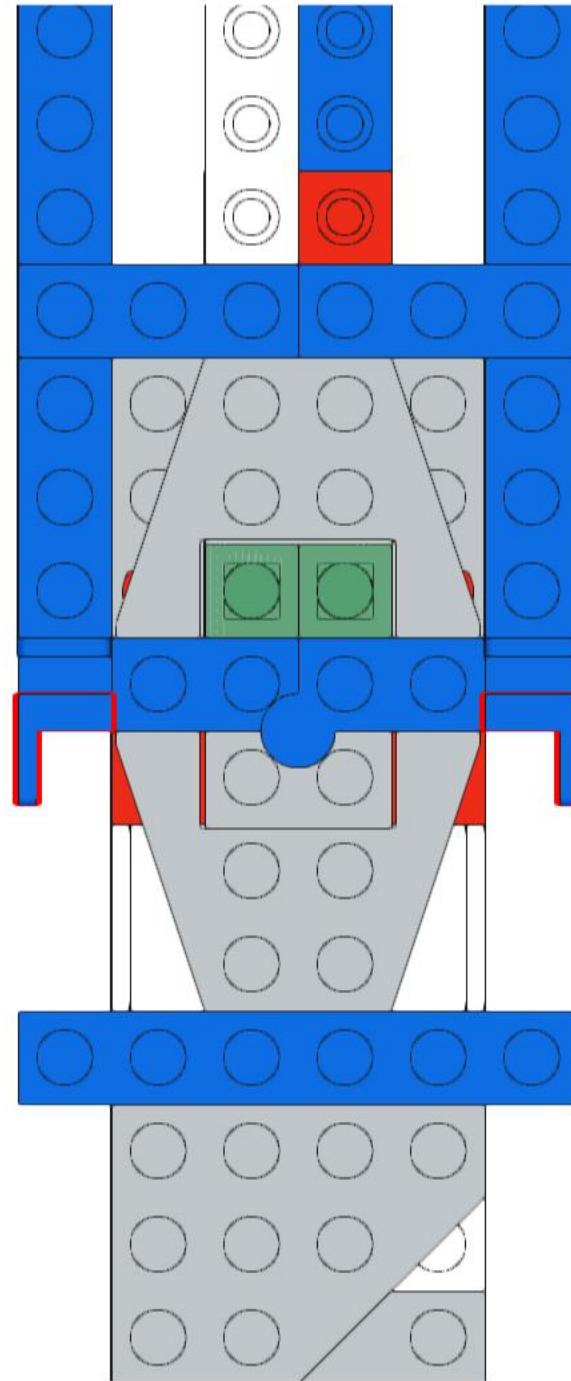
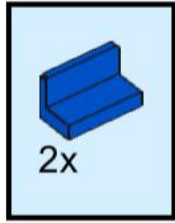

233

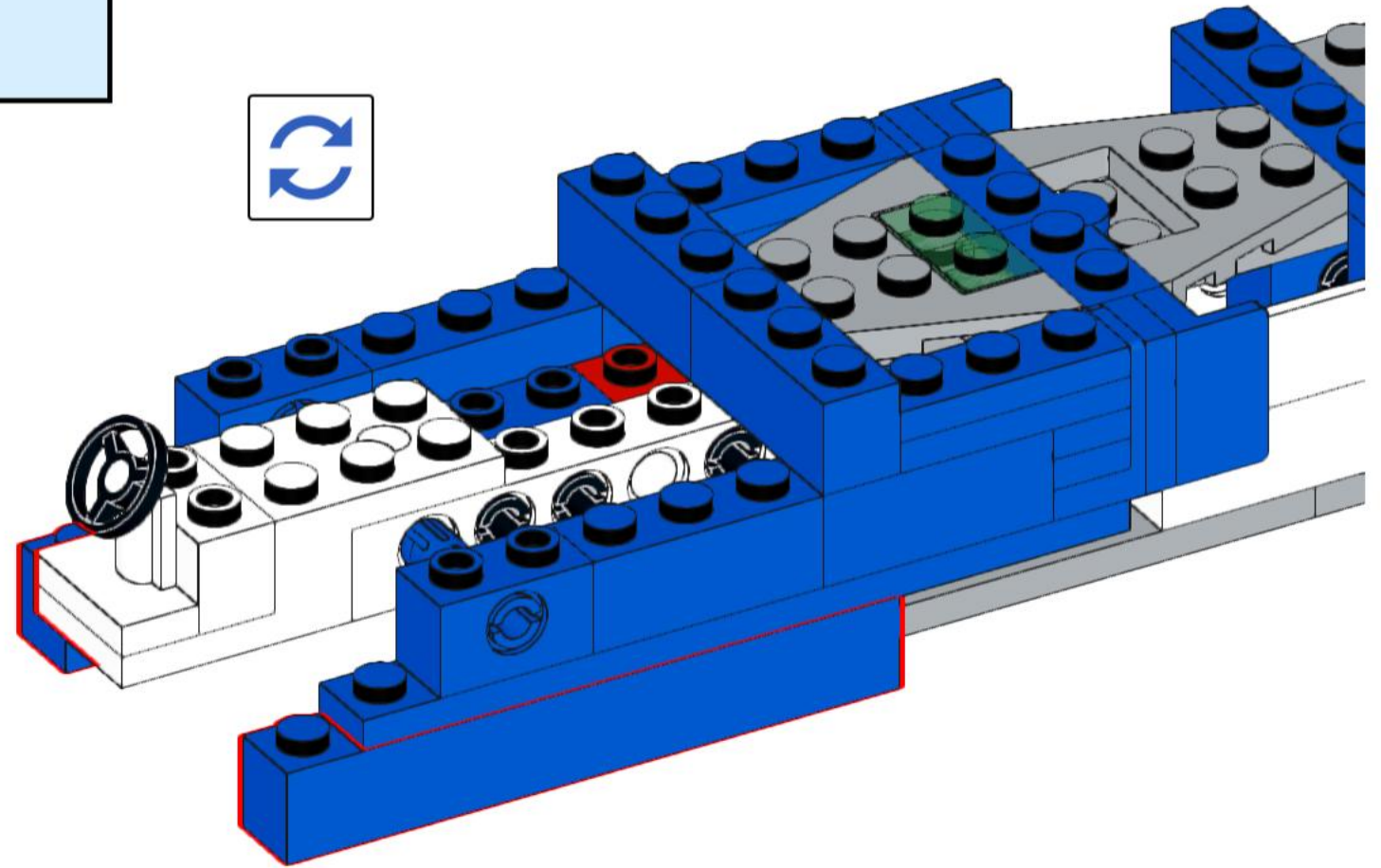
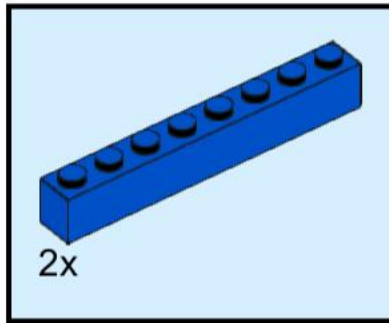

234

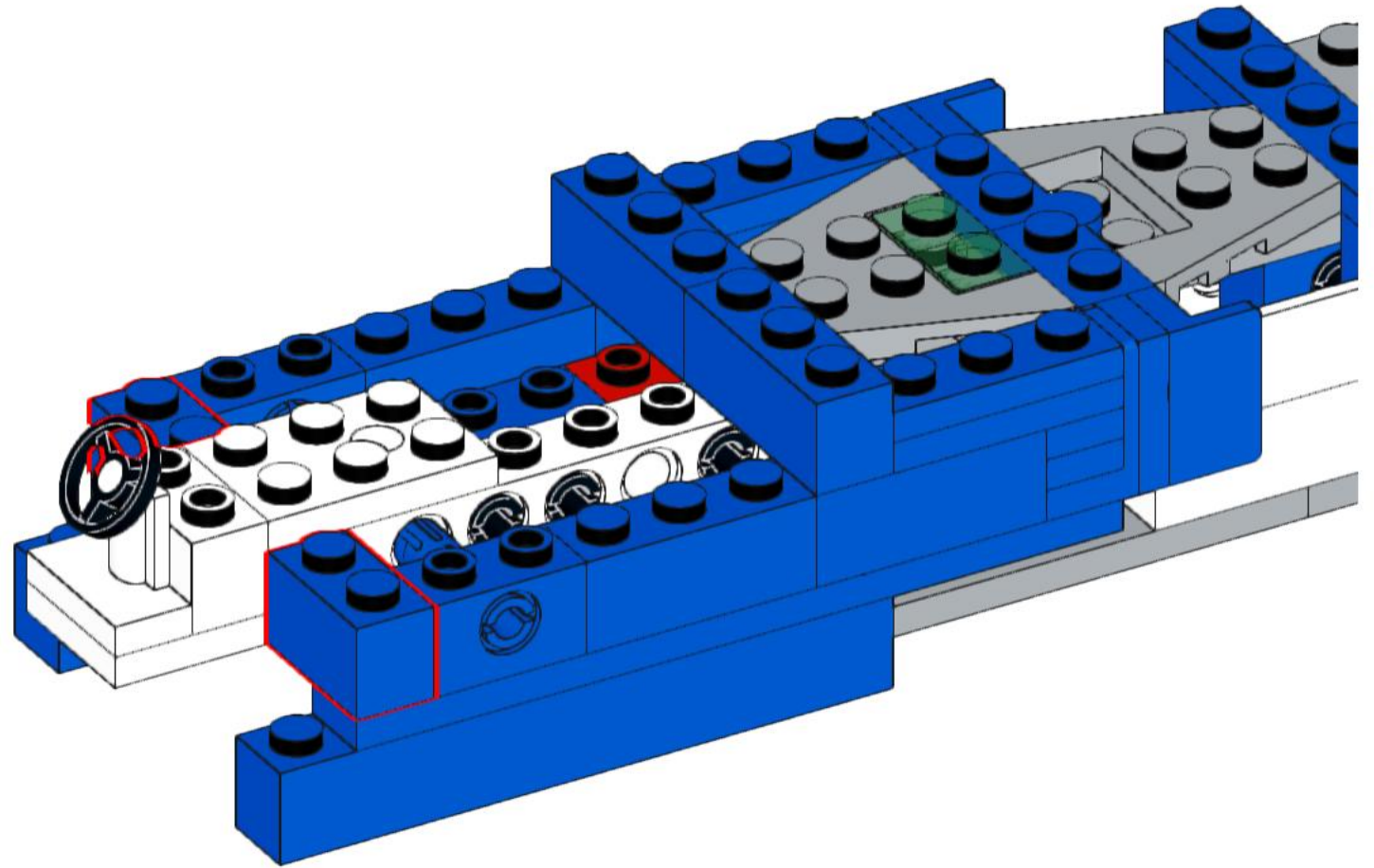
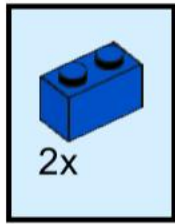

235

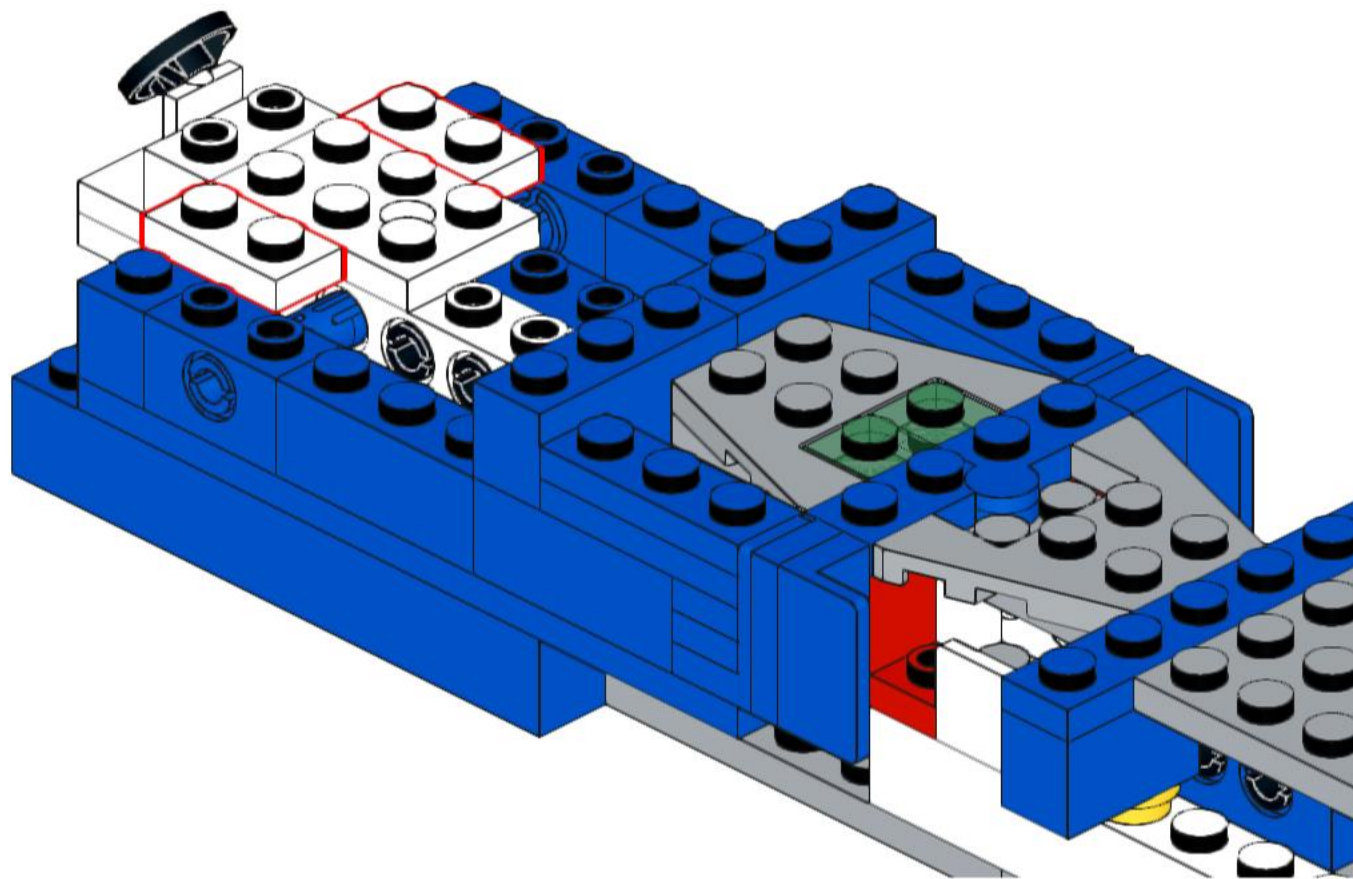
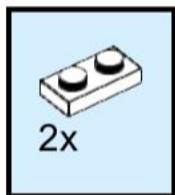

236

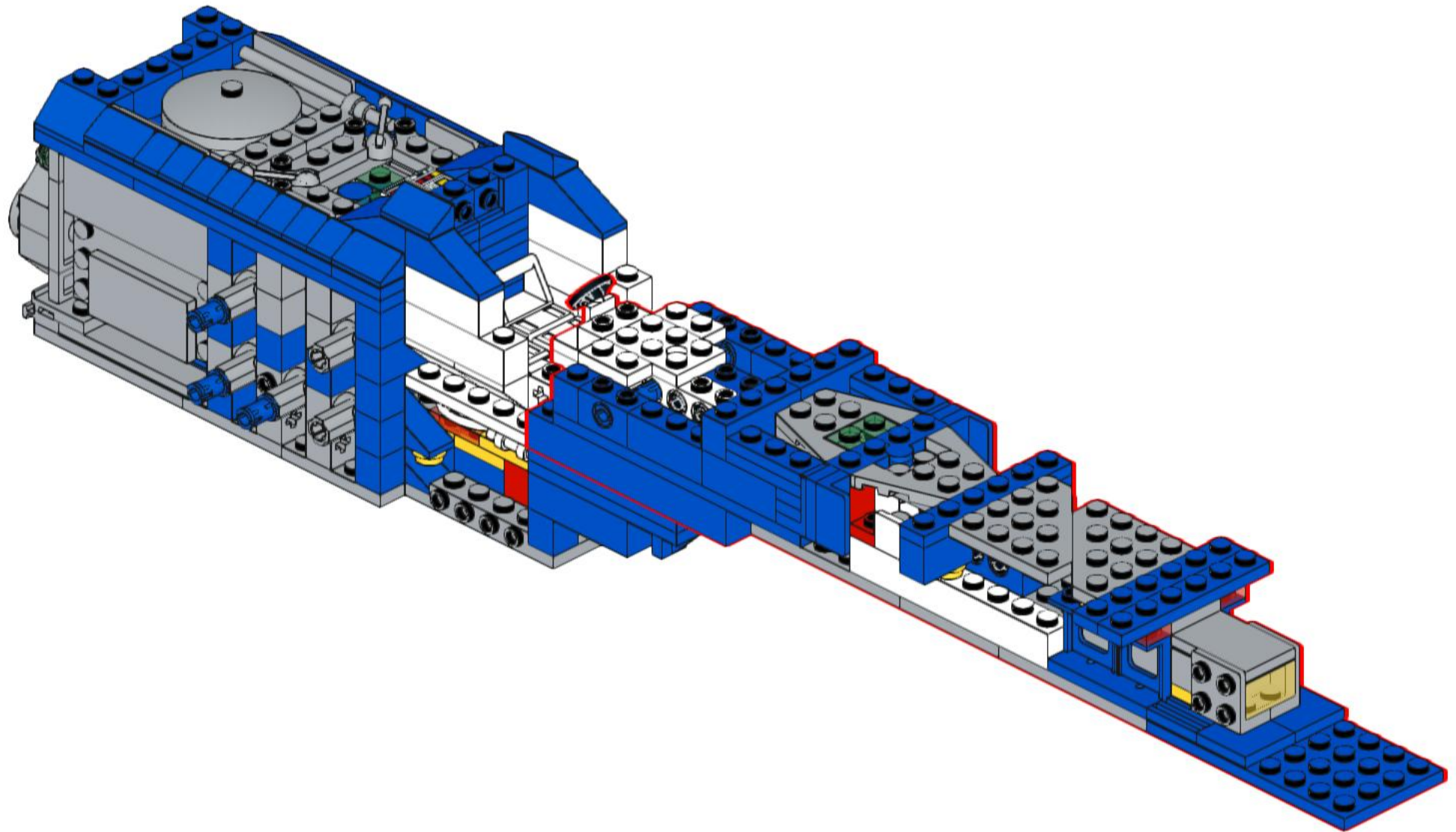

237

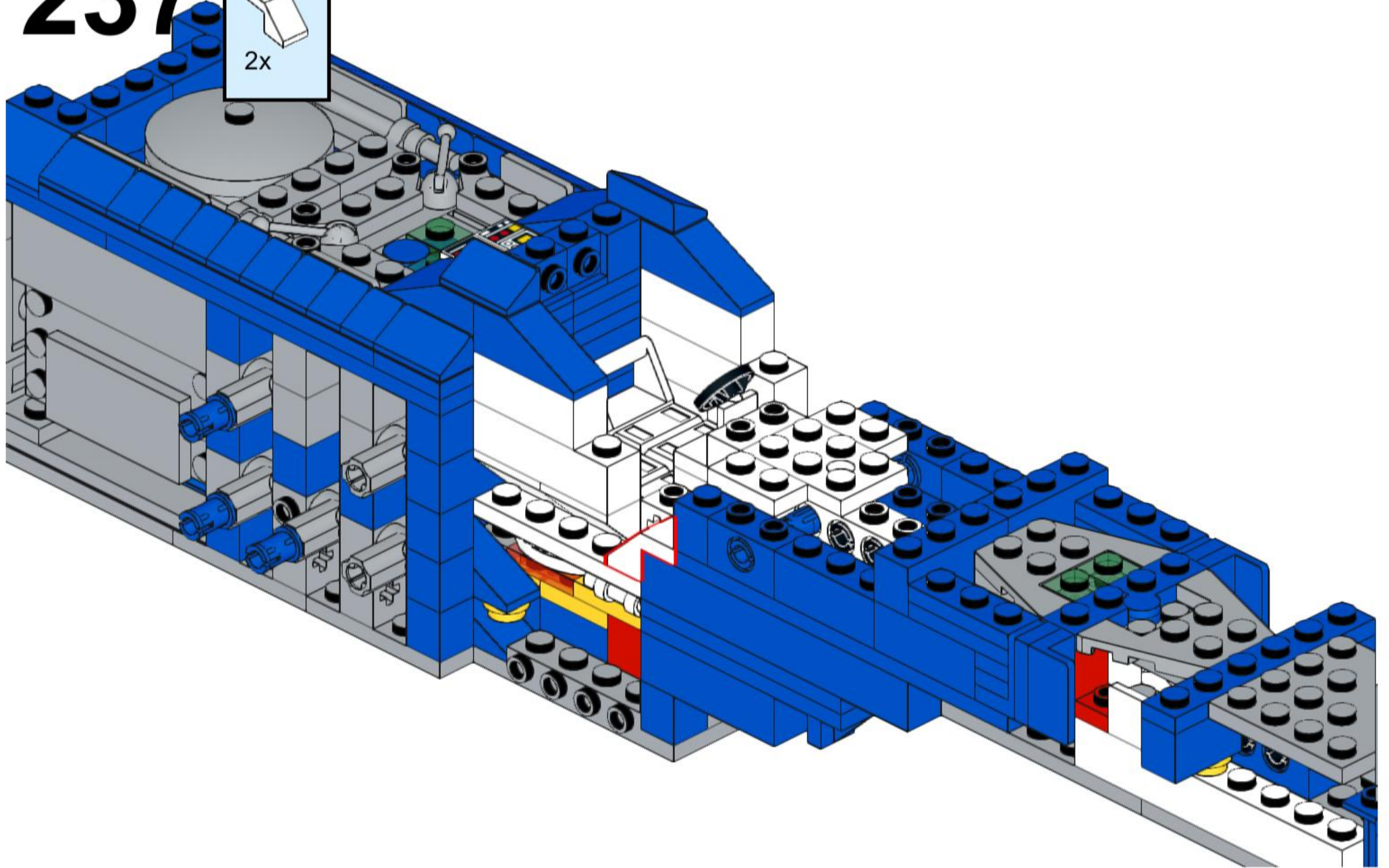
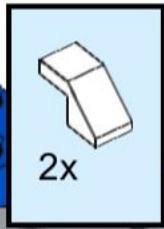

238

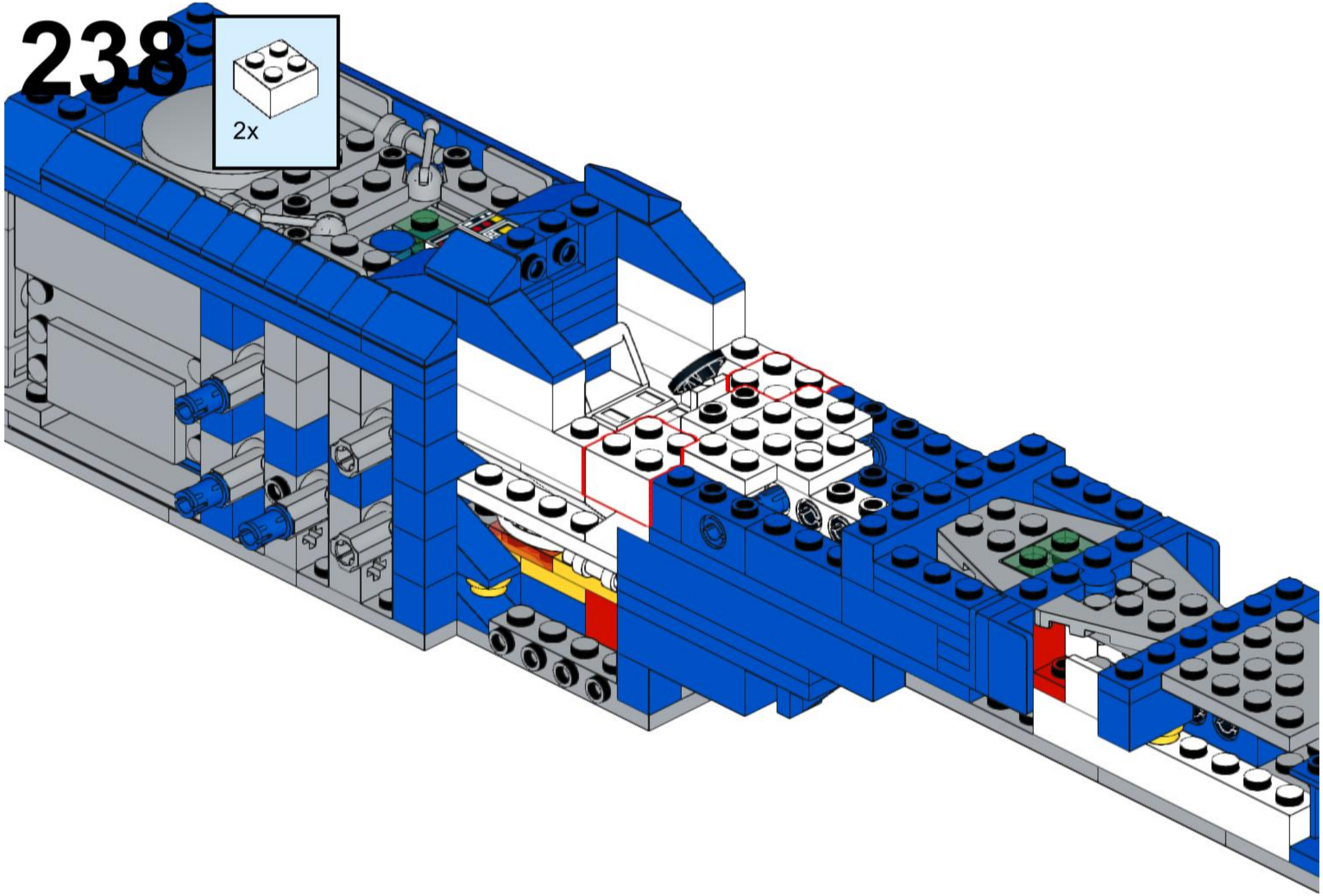
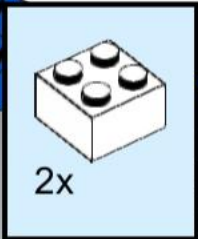

239

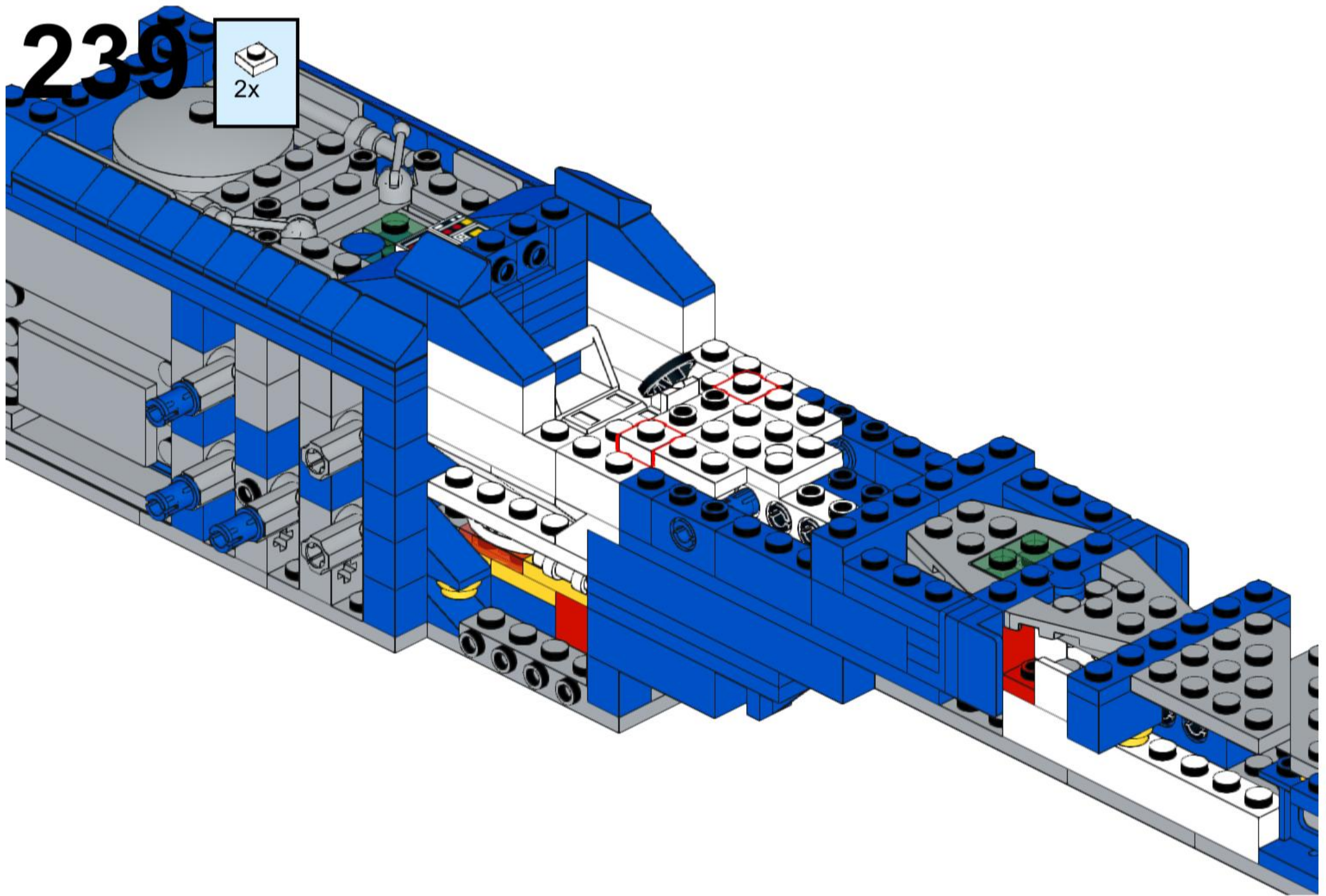

240

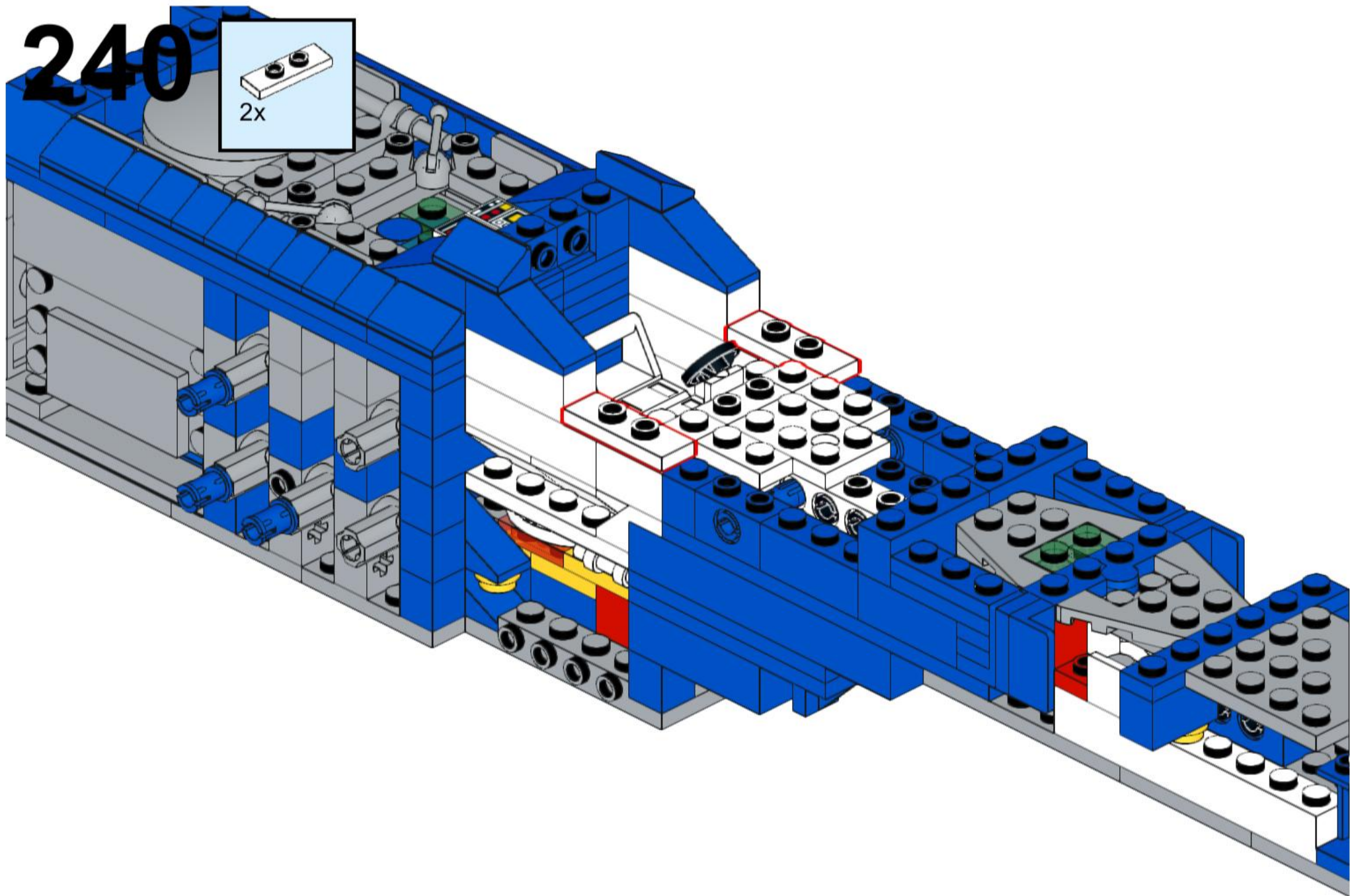
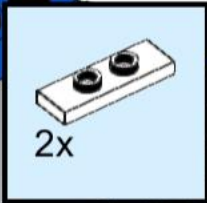

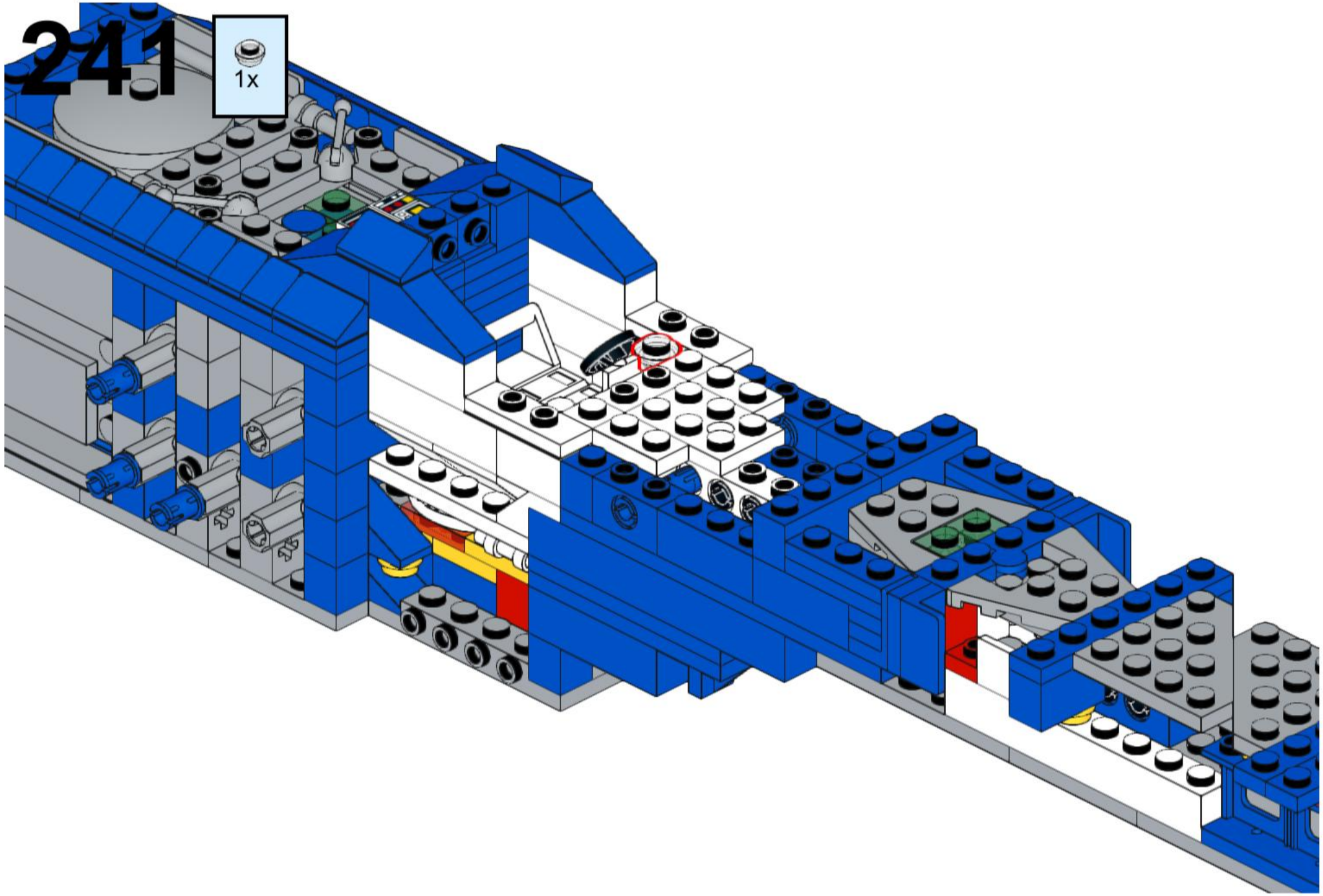

241

1x

242

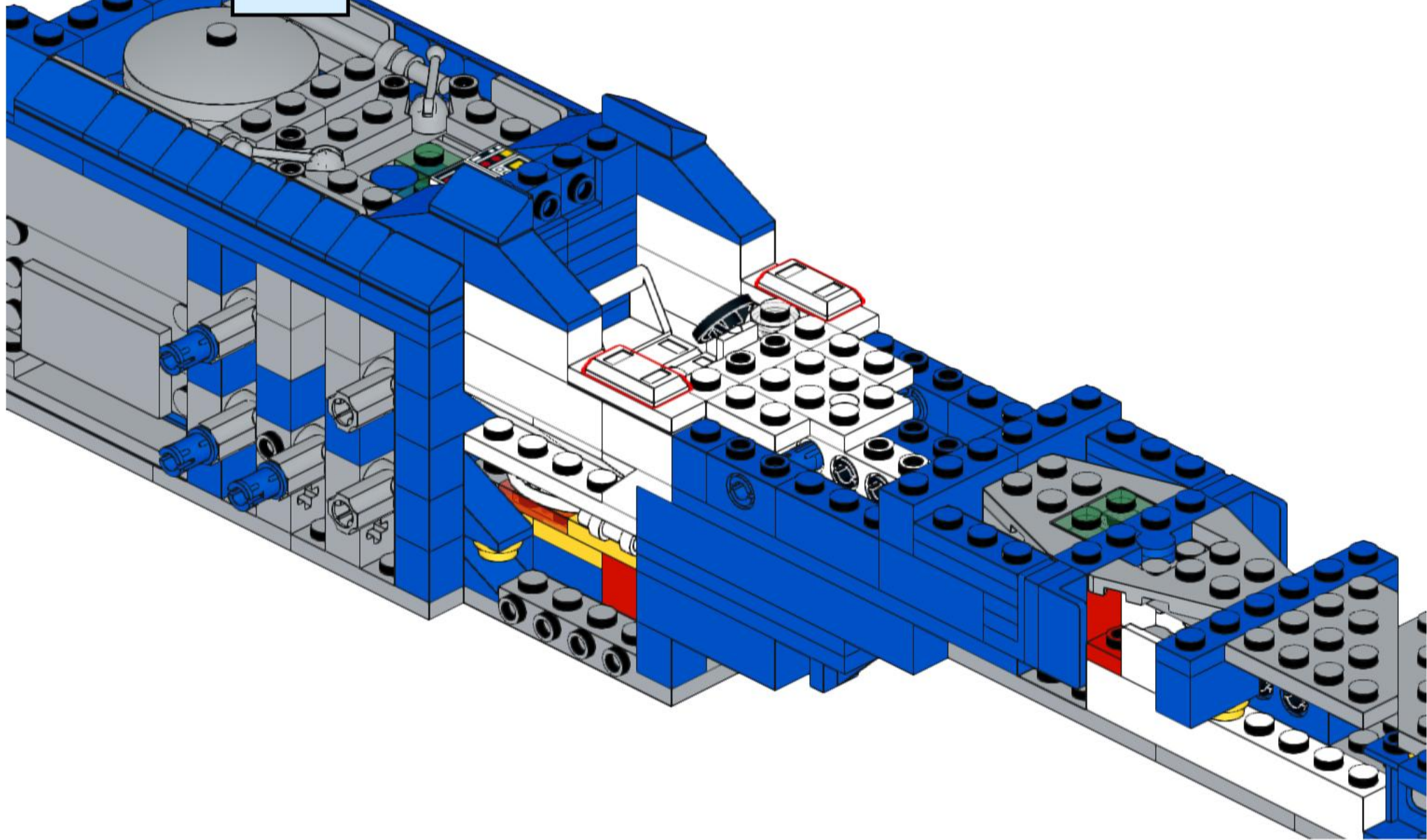
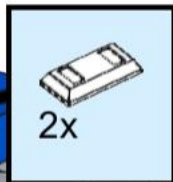

243

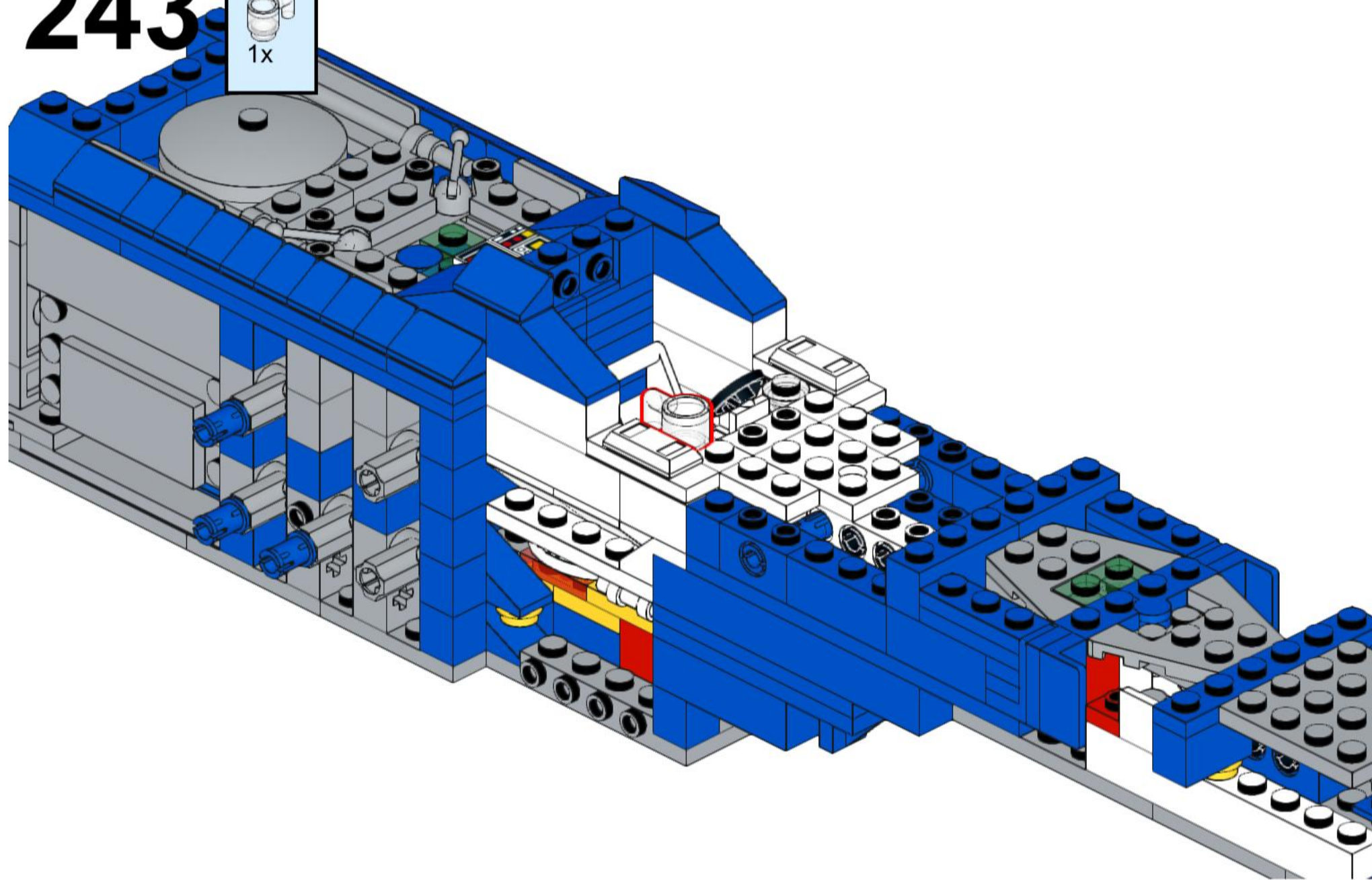

244

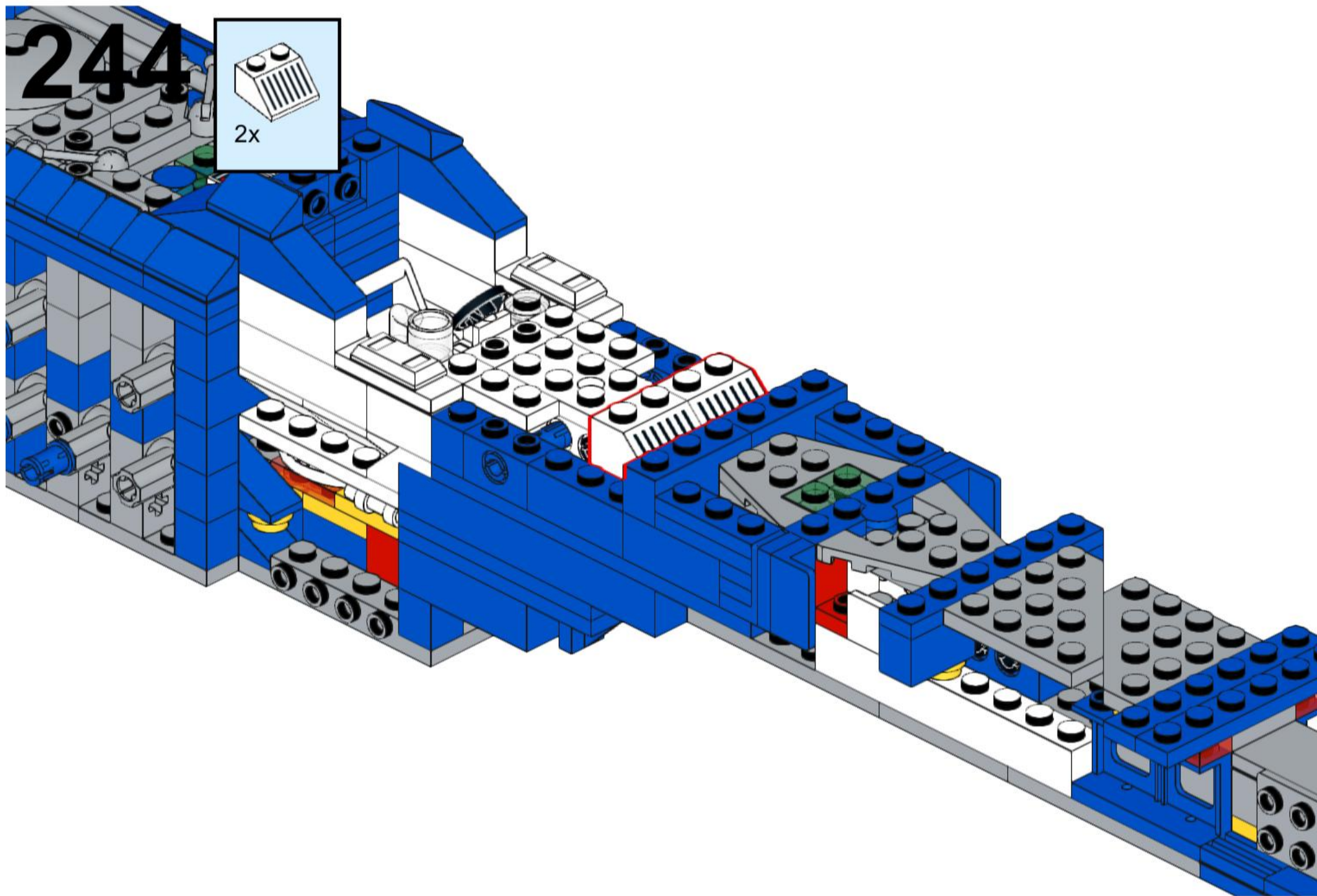
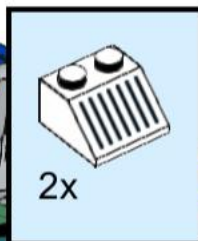

245

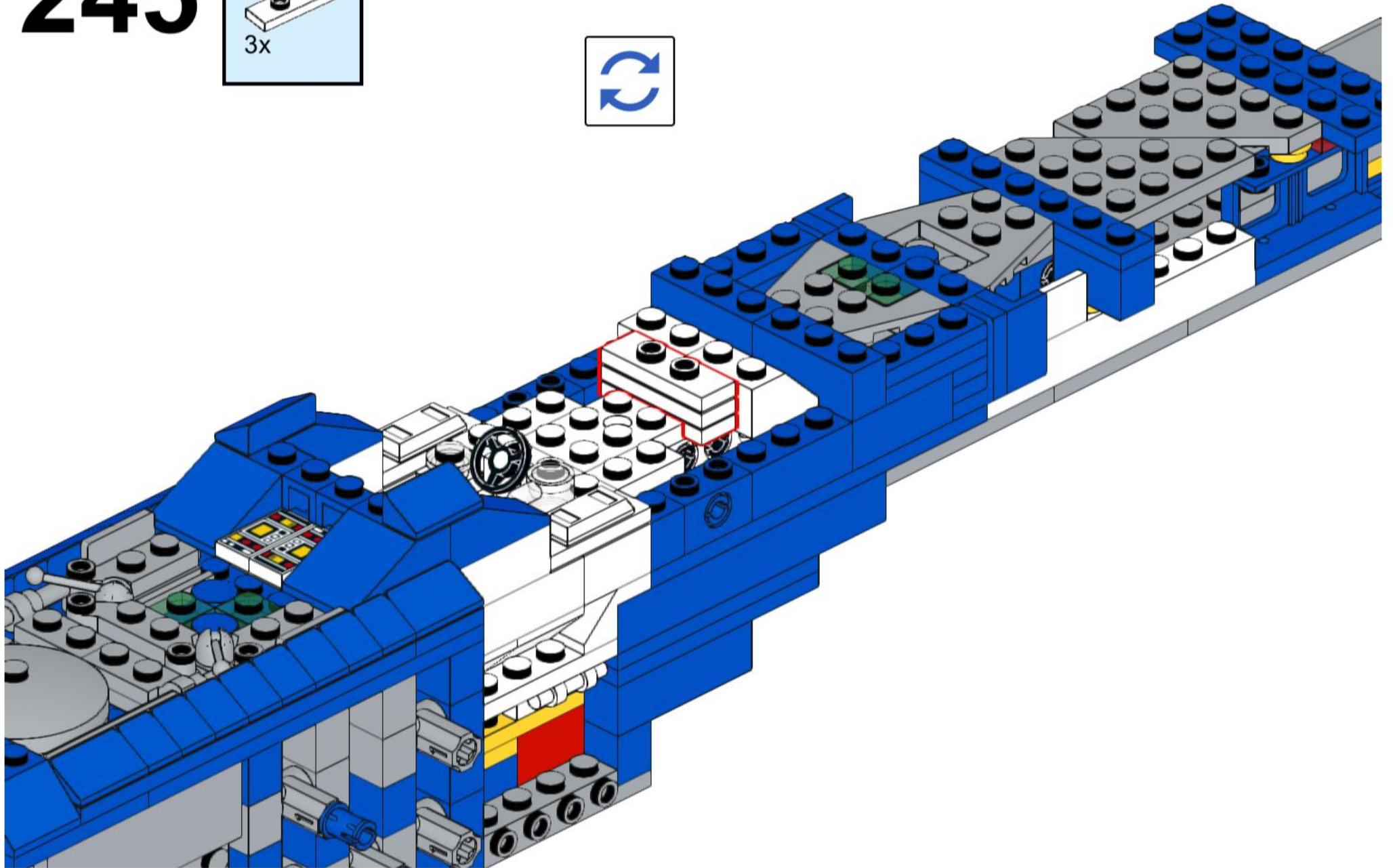
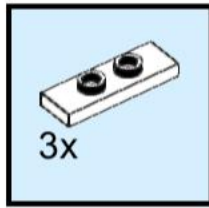

246

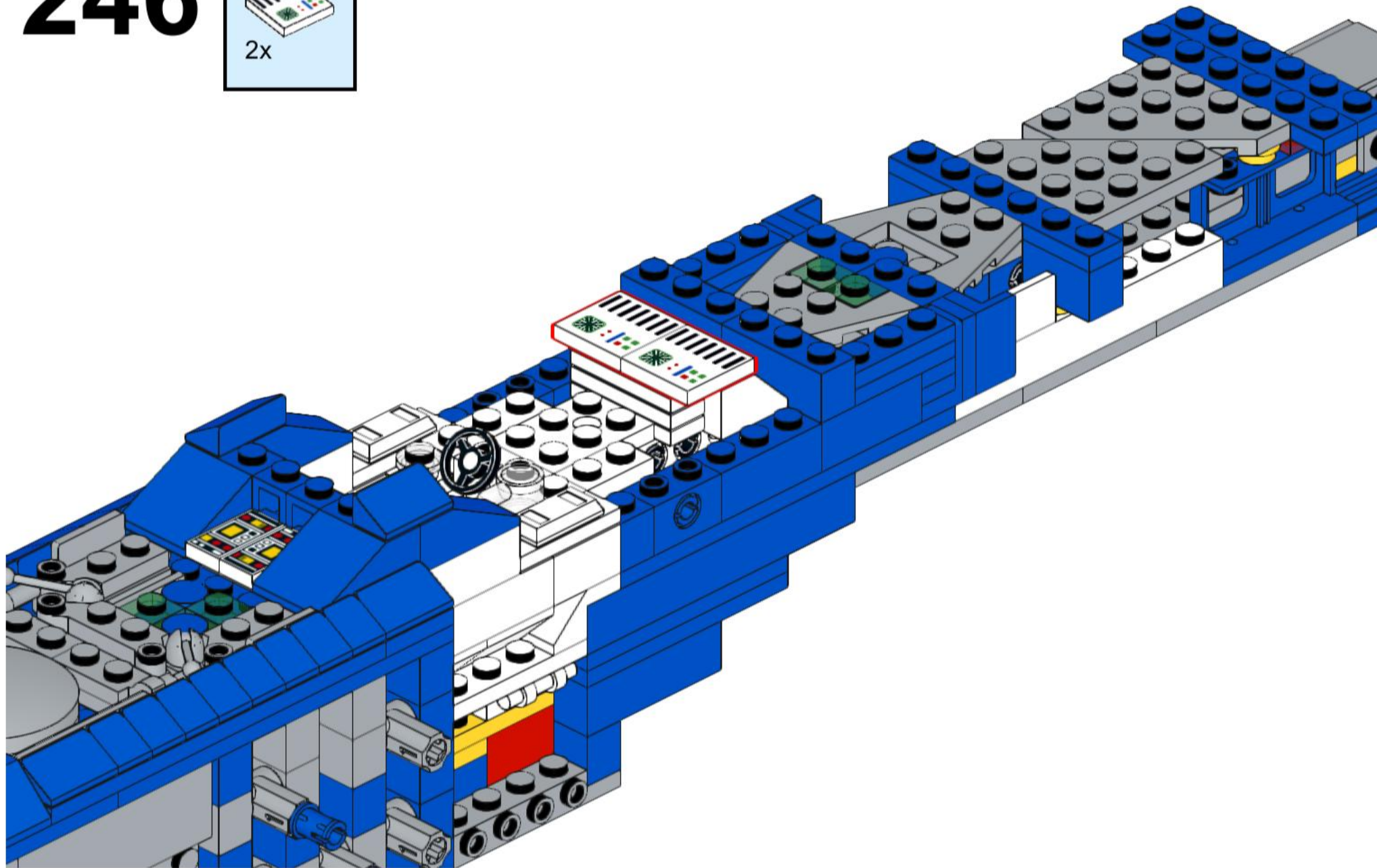
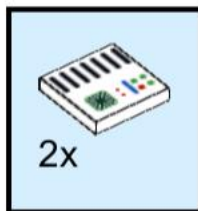

247

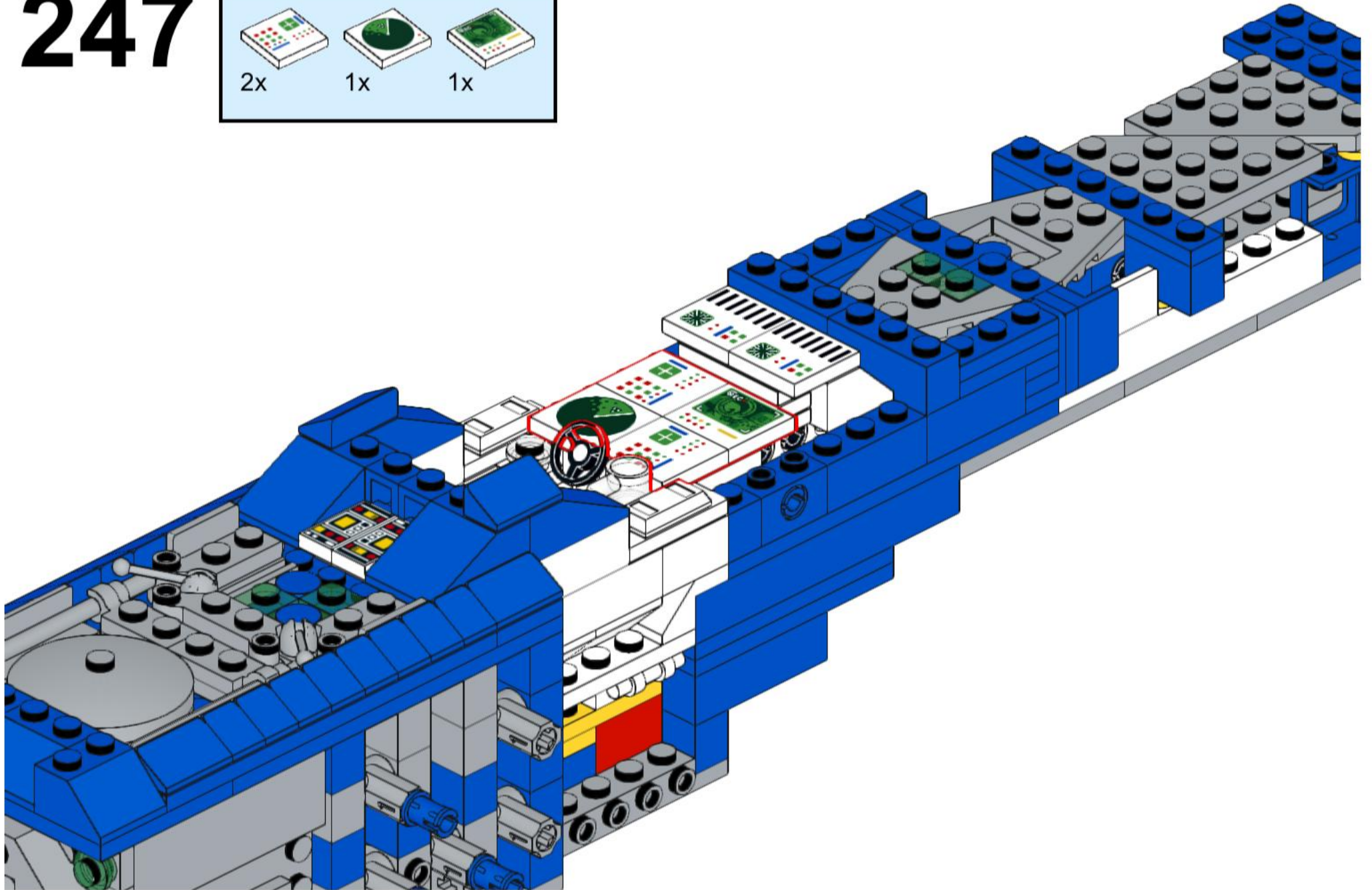
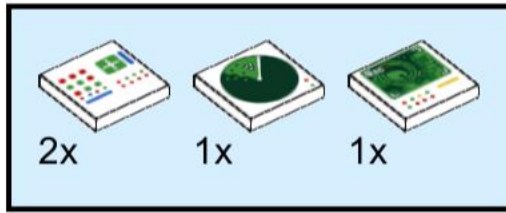

248

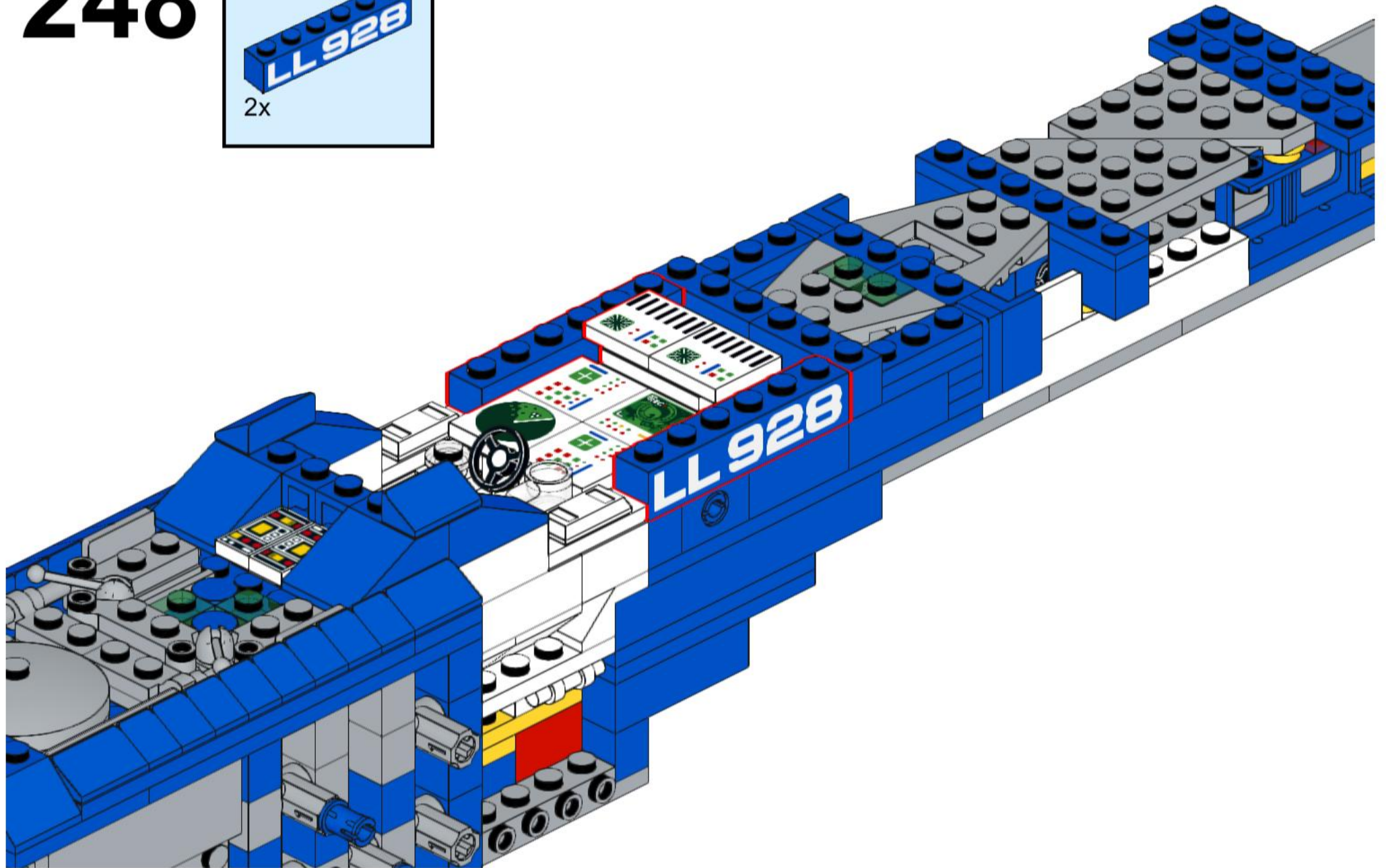
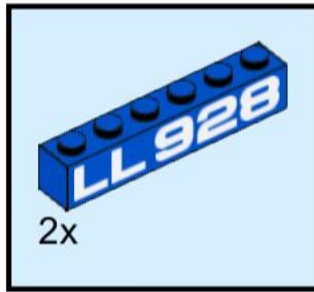

249

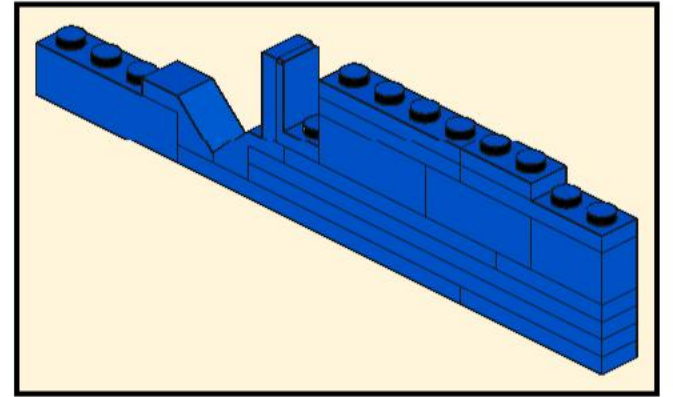
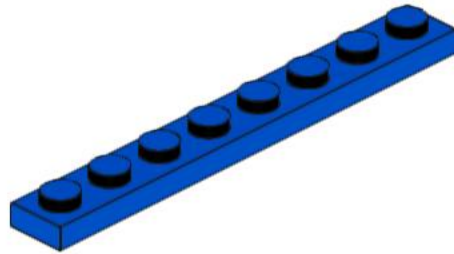
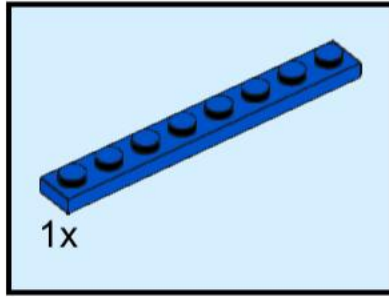

250

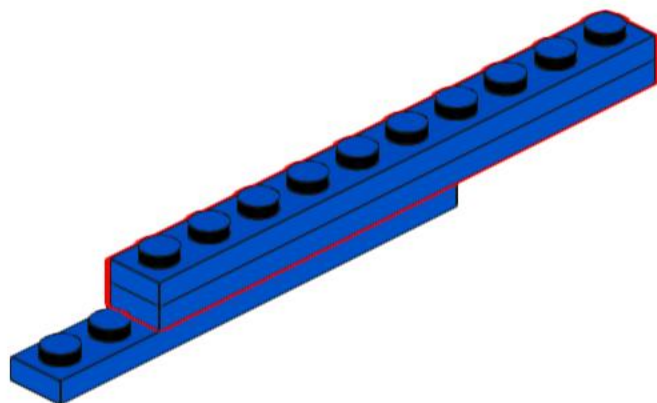
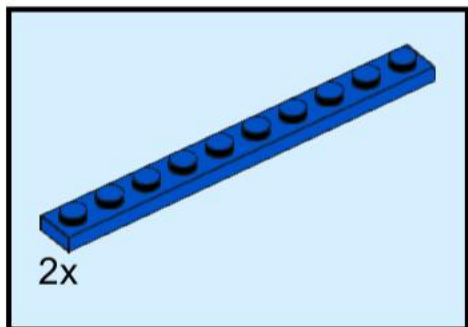

251

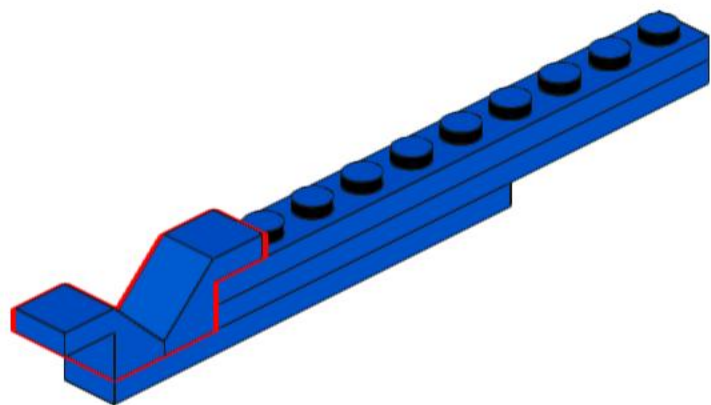
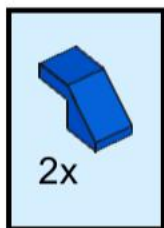

252

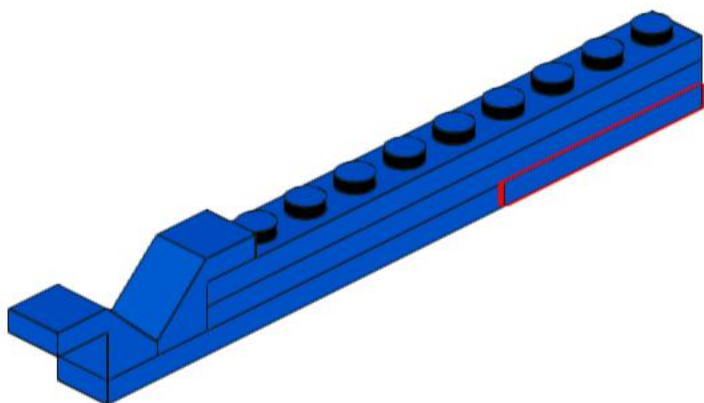
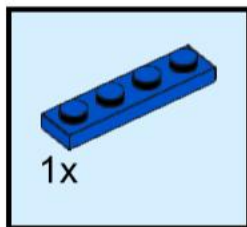

253

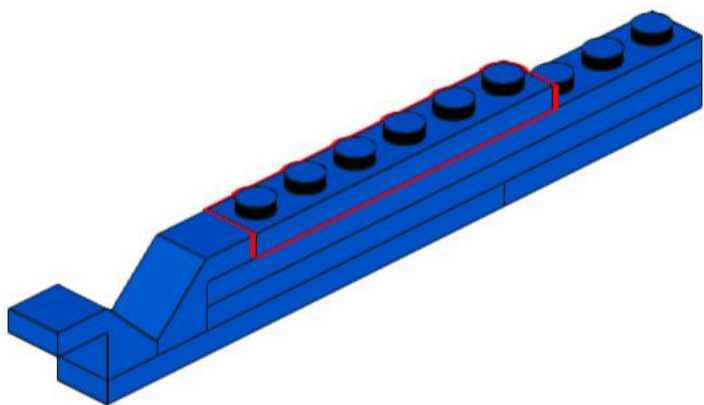
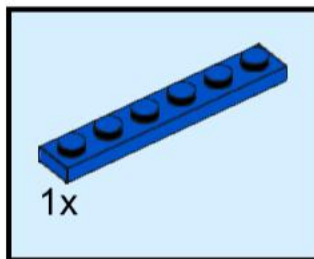

254

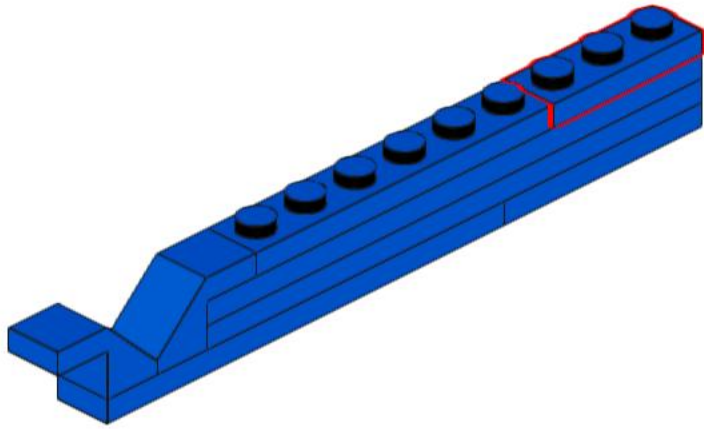
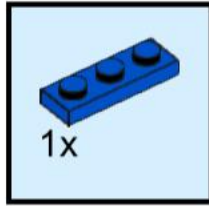

255

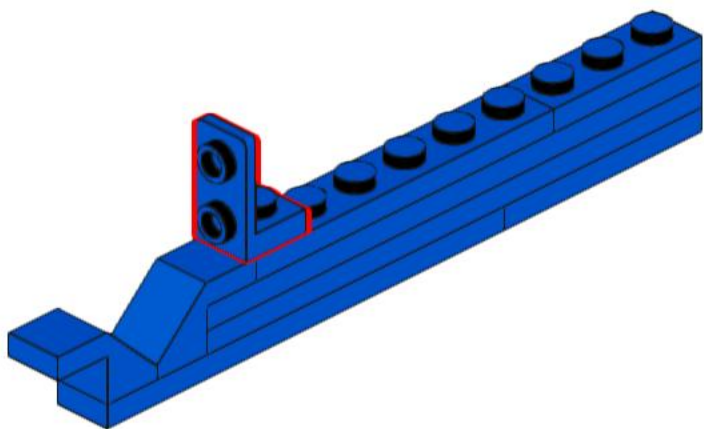
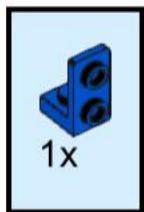

256

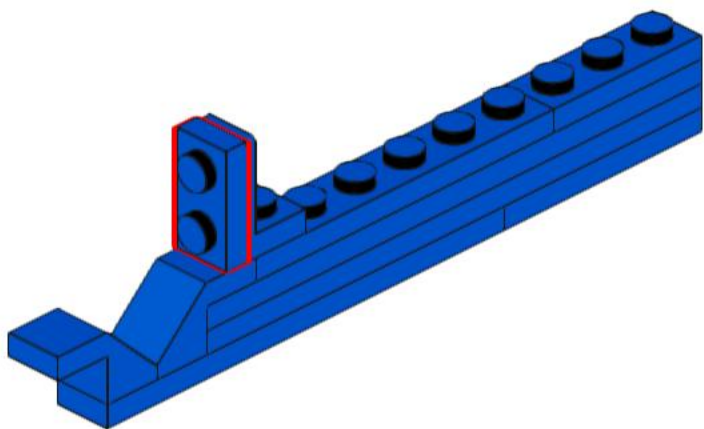
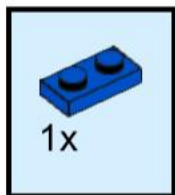

257

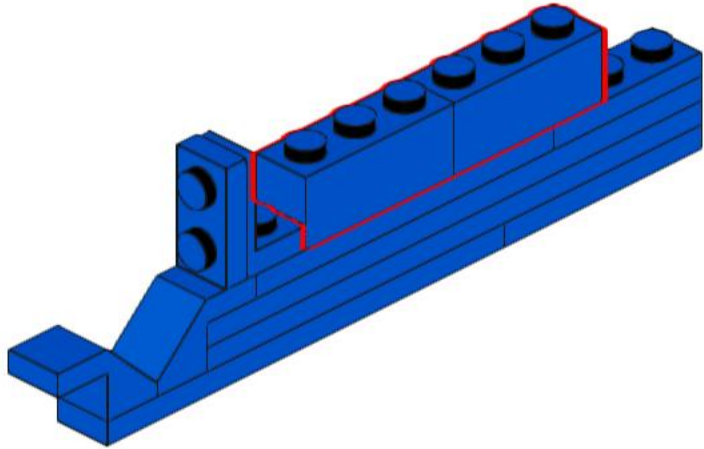
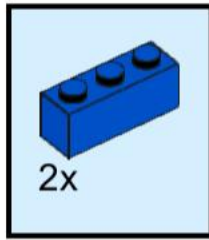

258

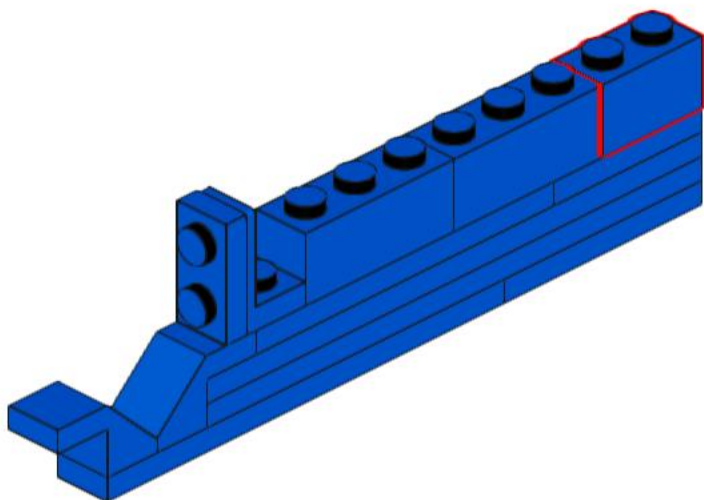
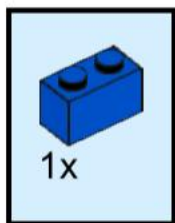

259

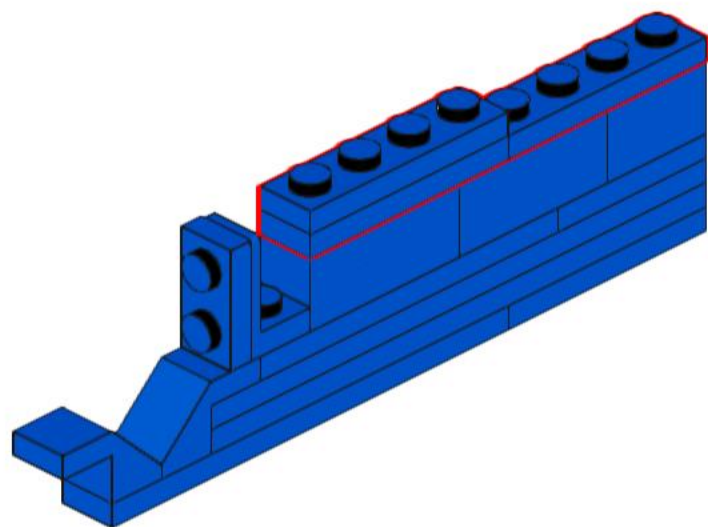
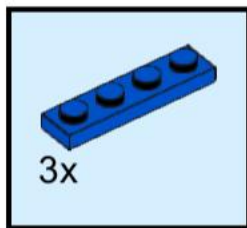

260

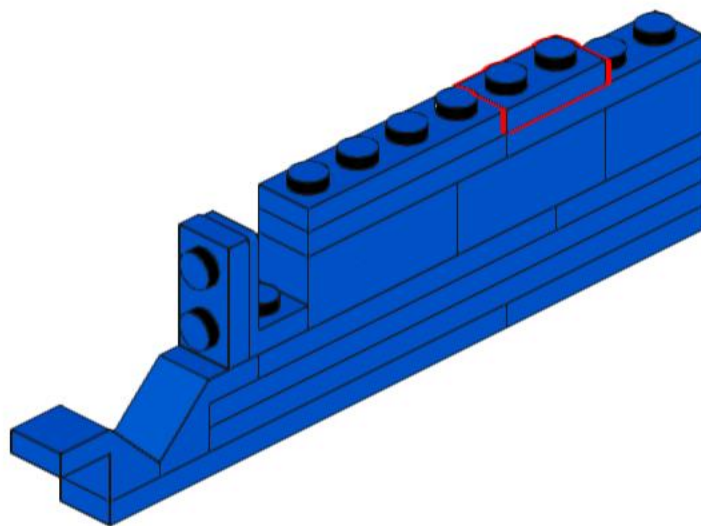
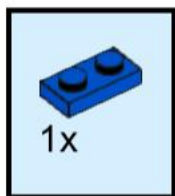

261

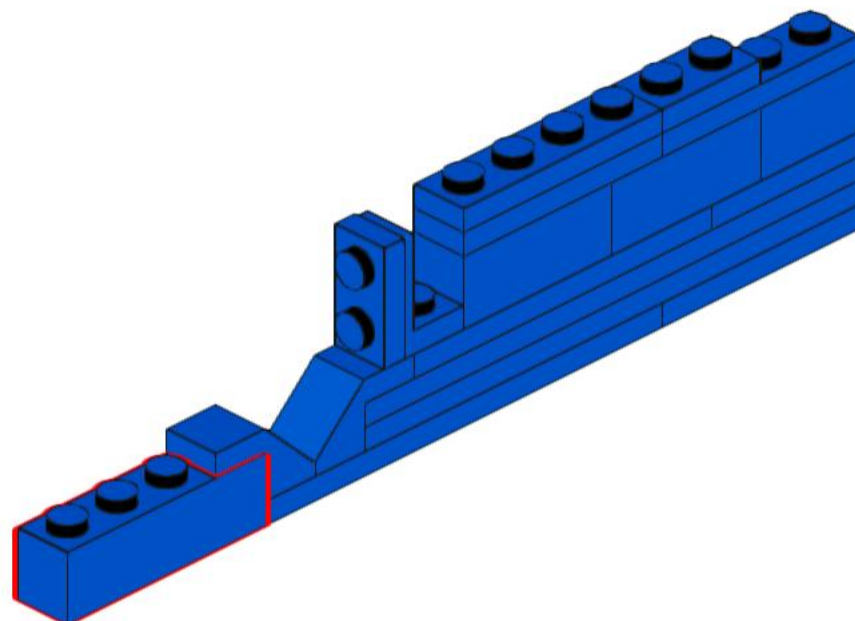
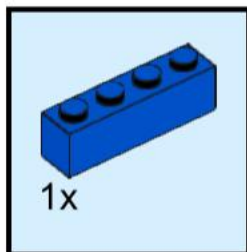

262

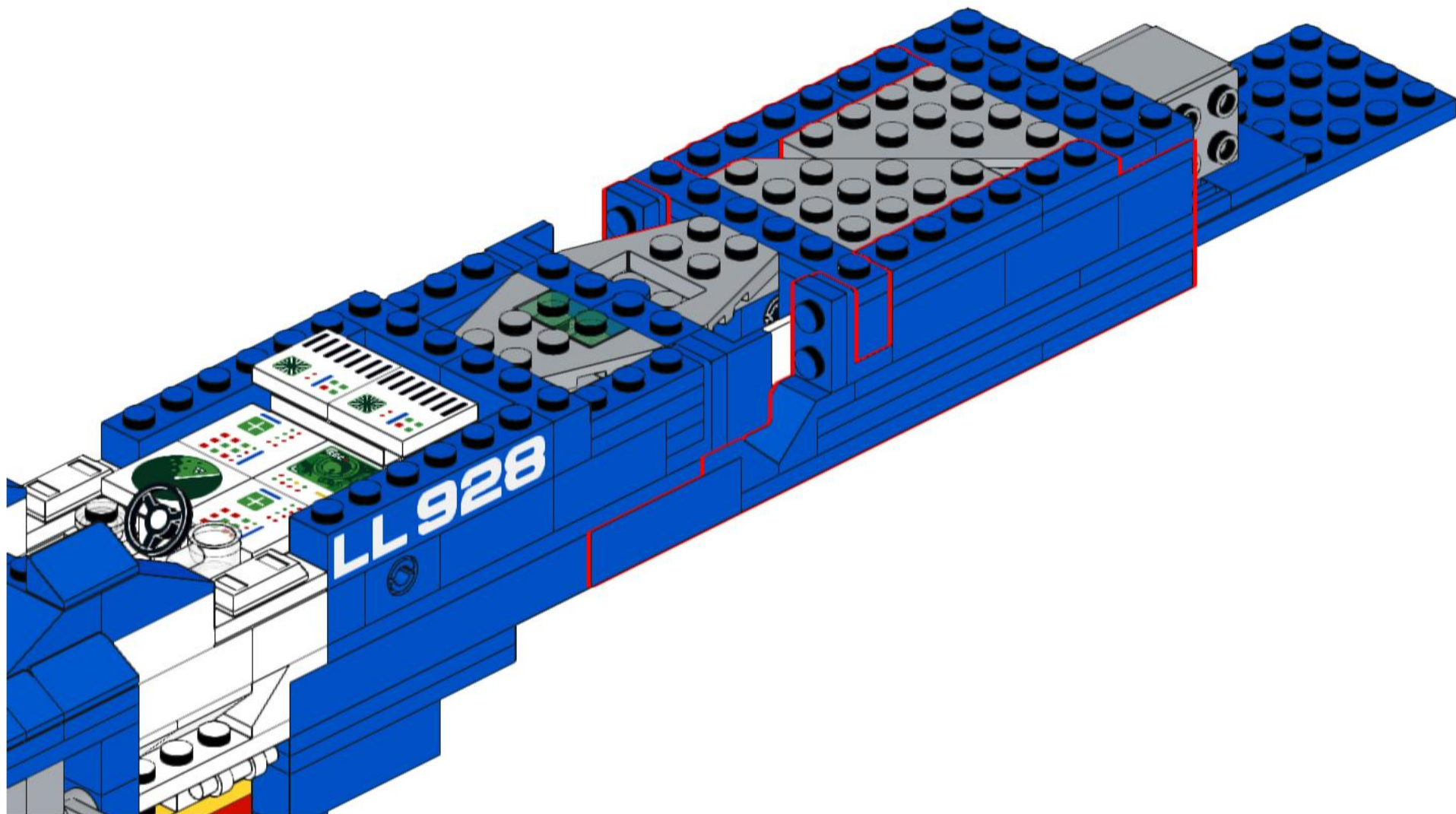

263

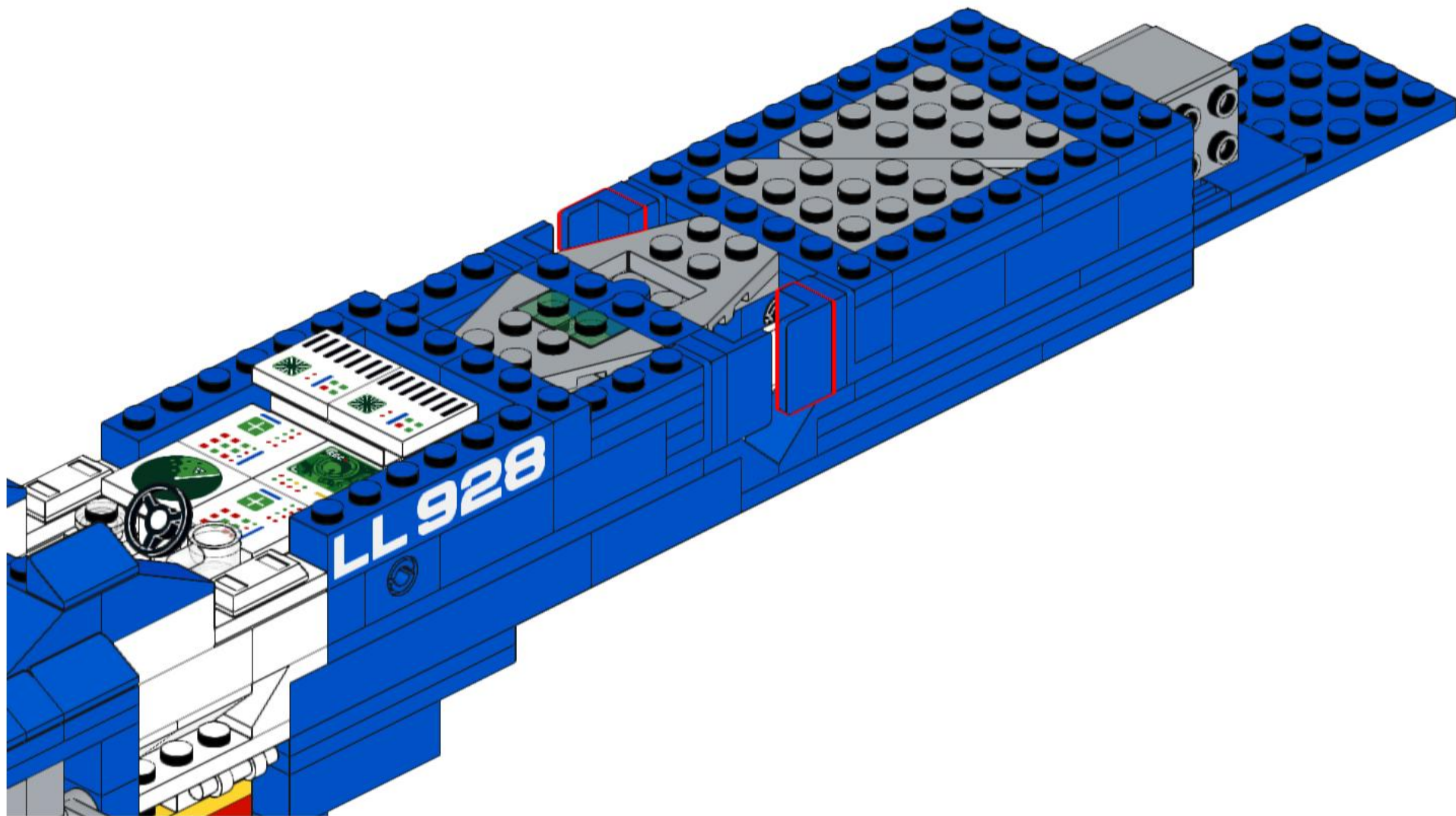
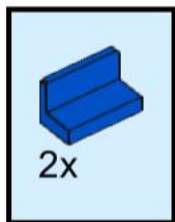

264

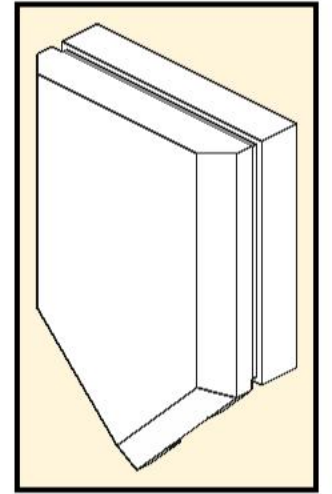
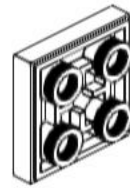
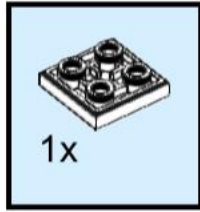

2x



265

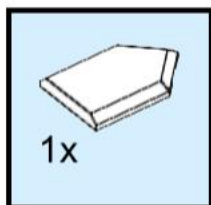

266

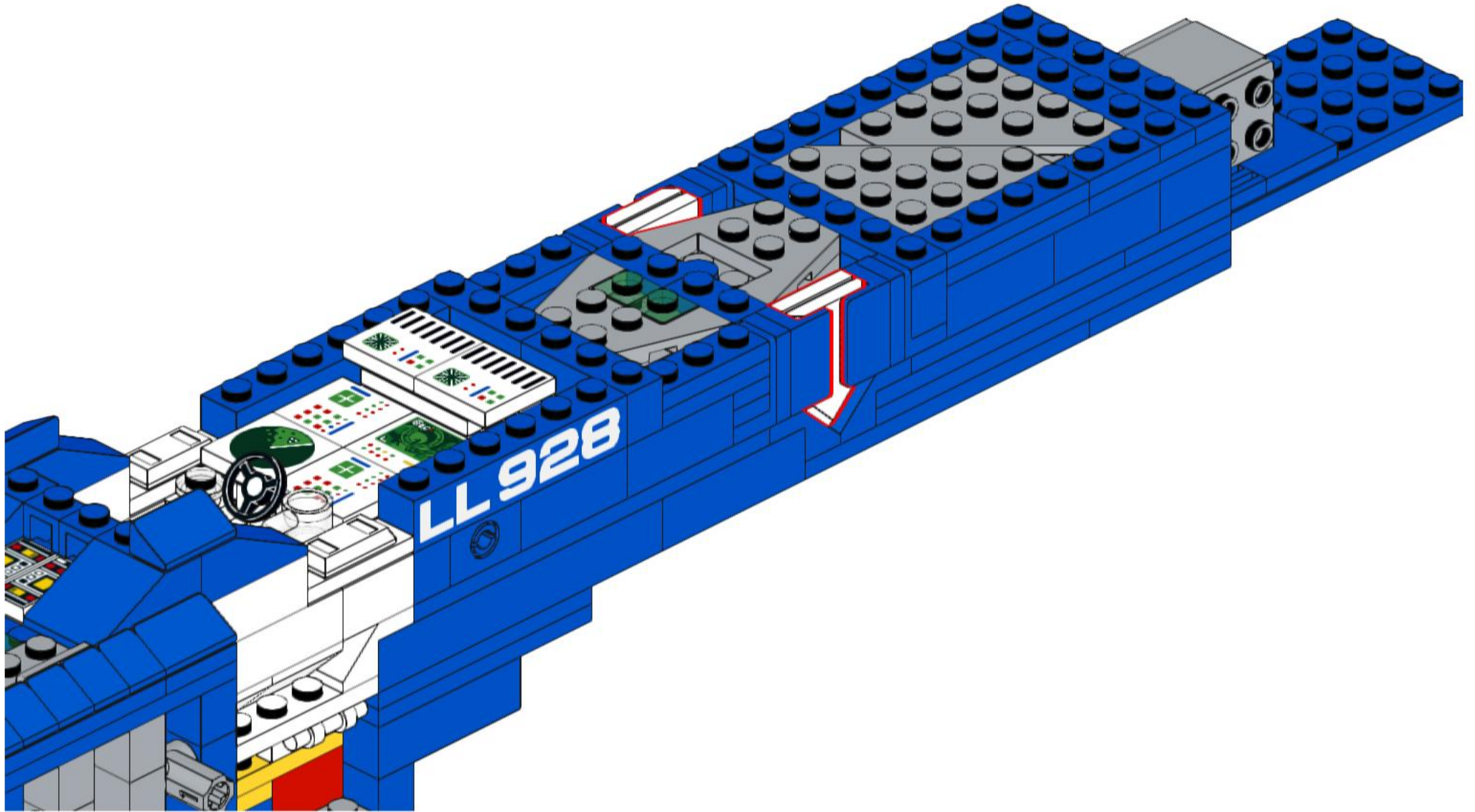

267

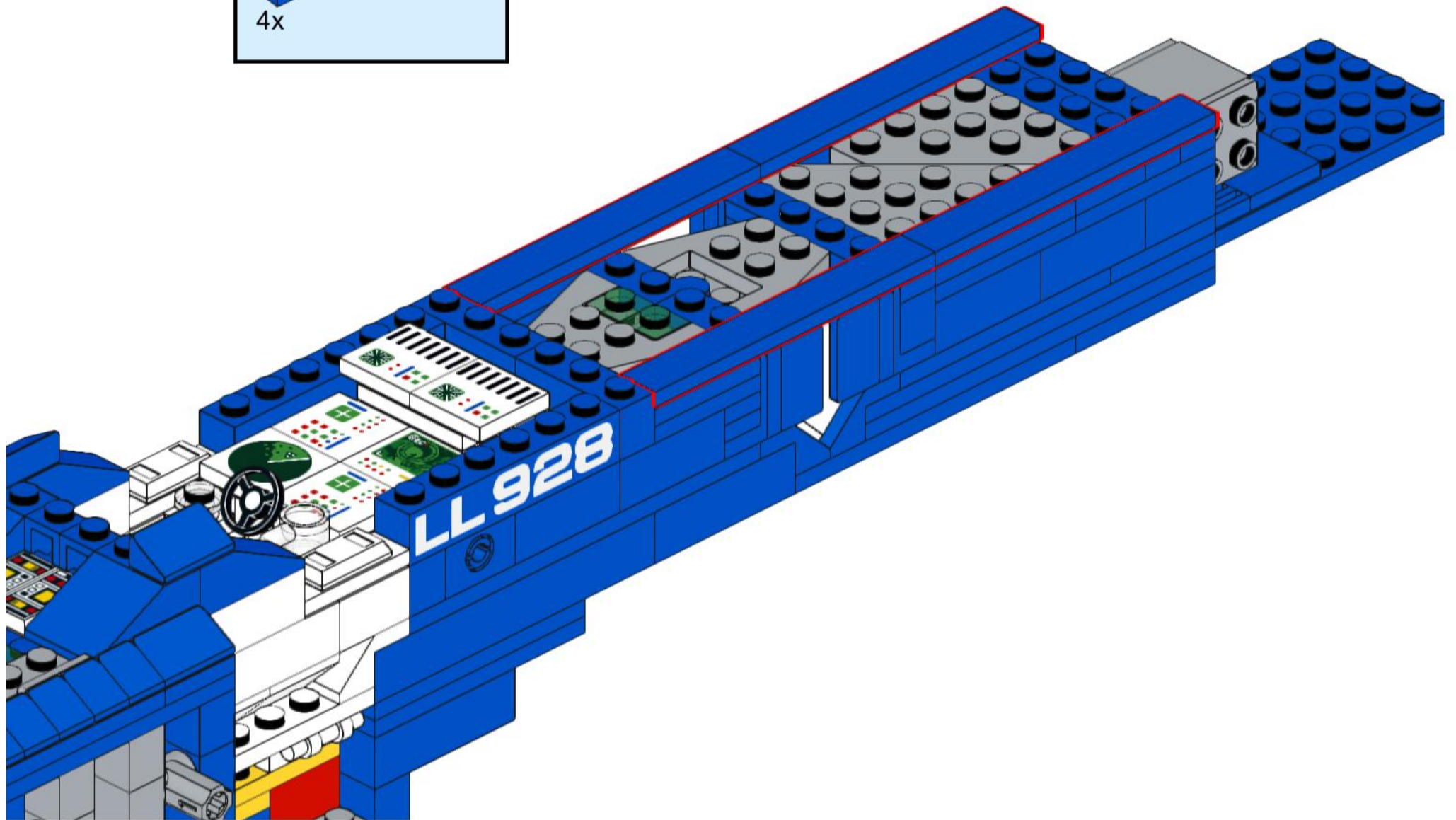
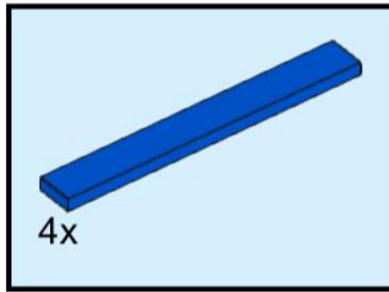

268

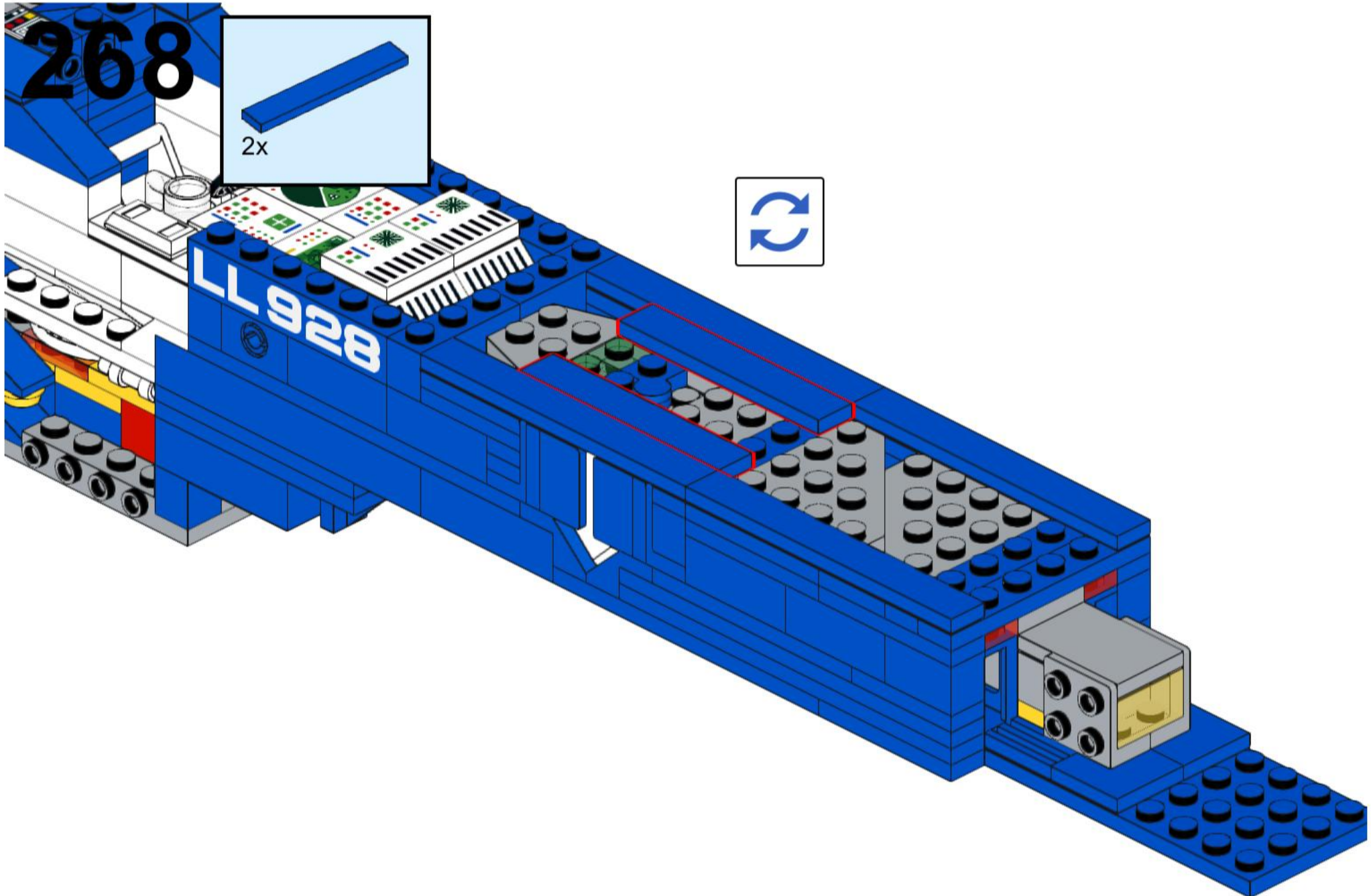
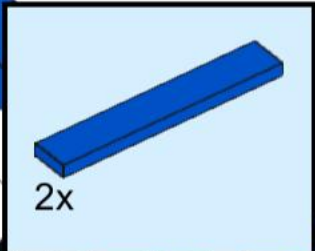

269

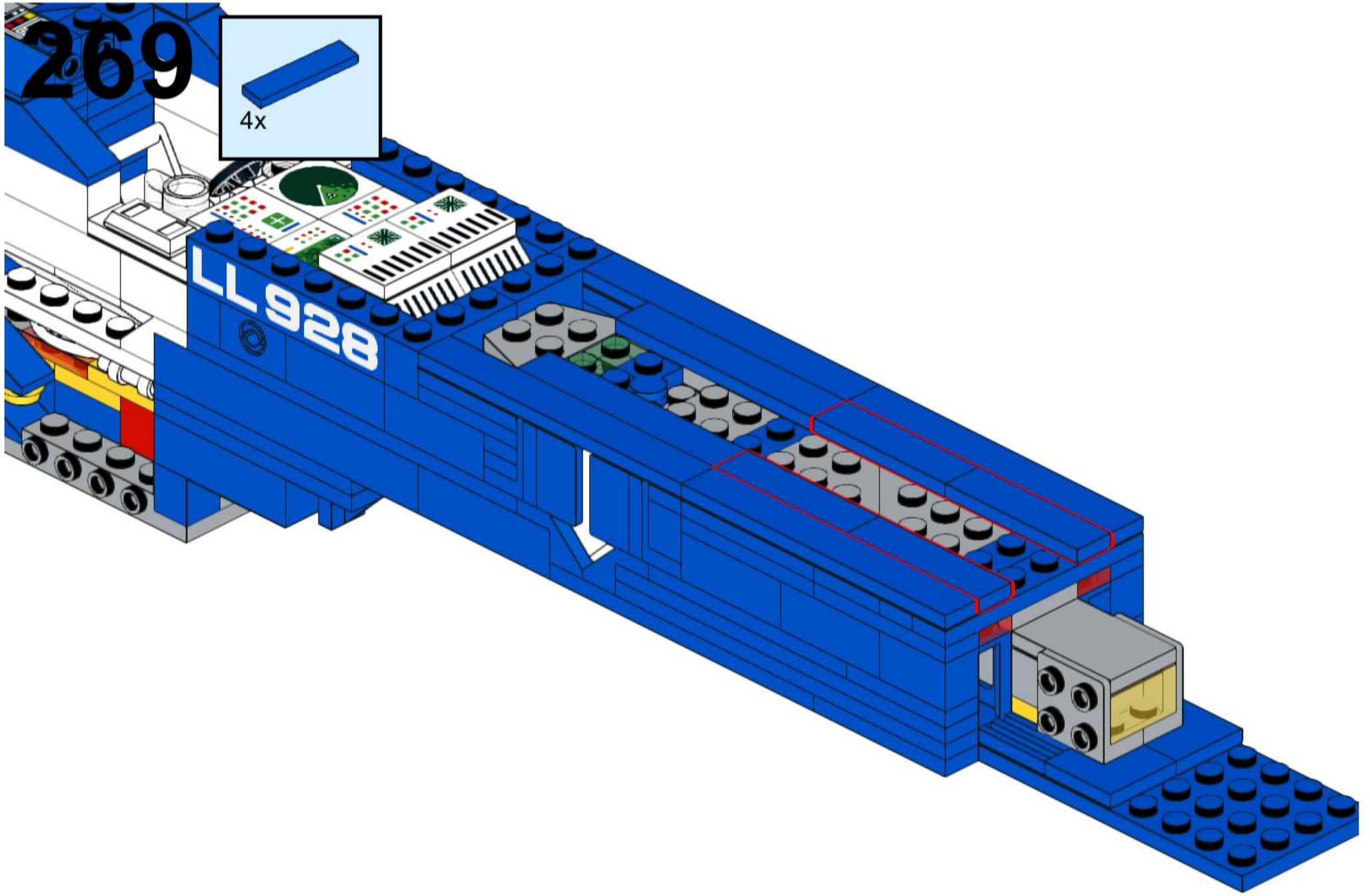
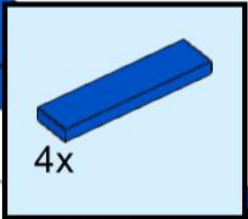

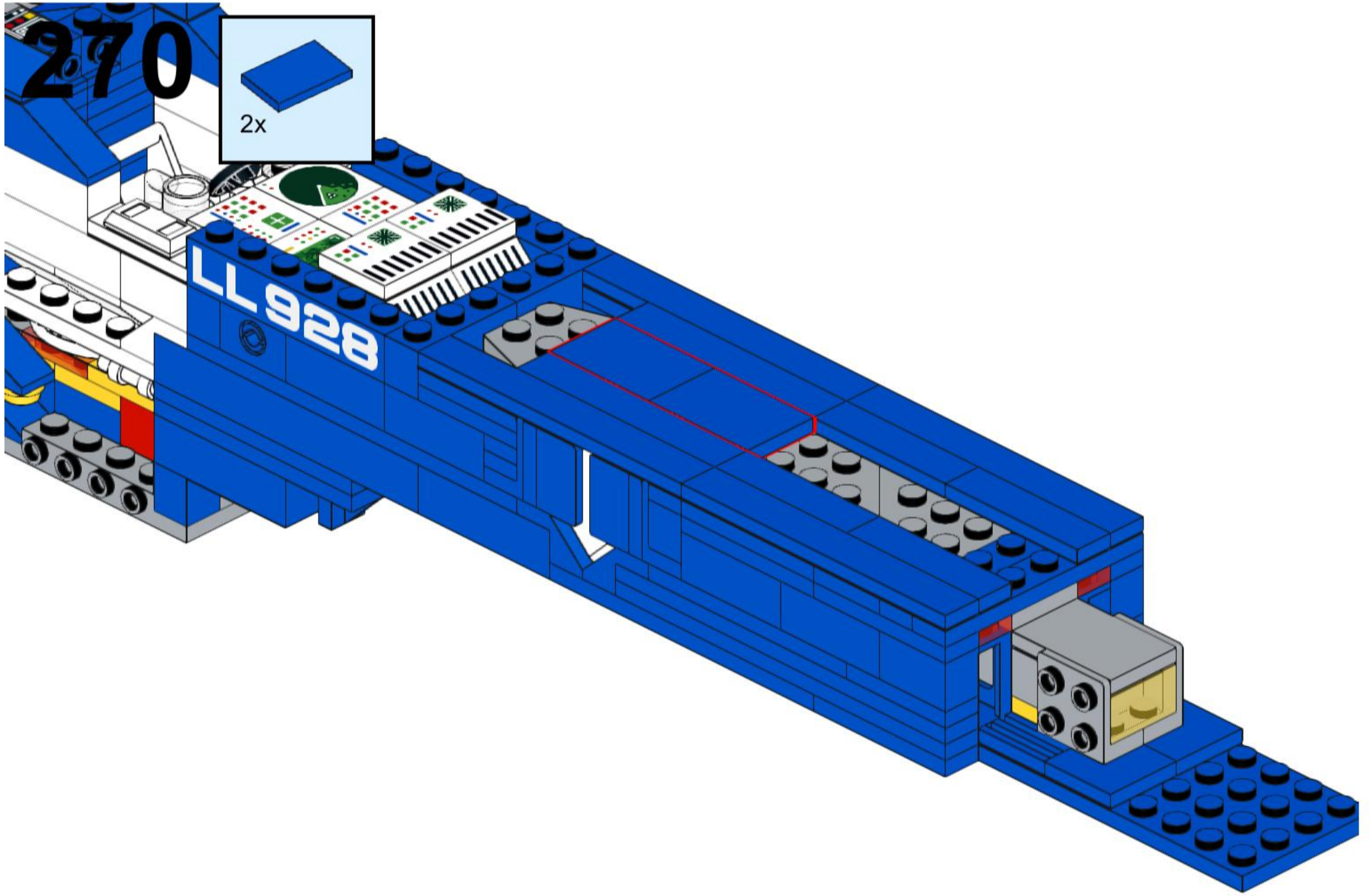

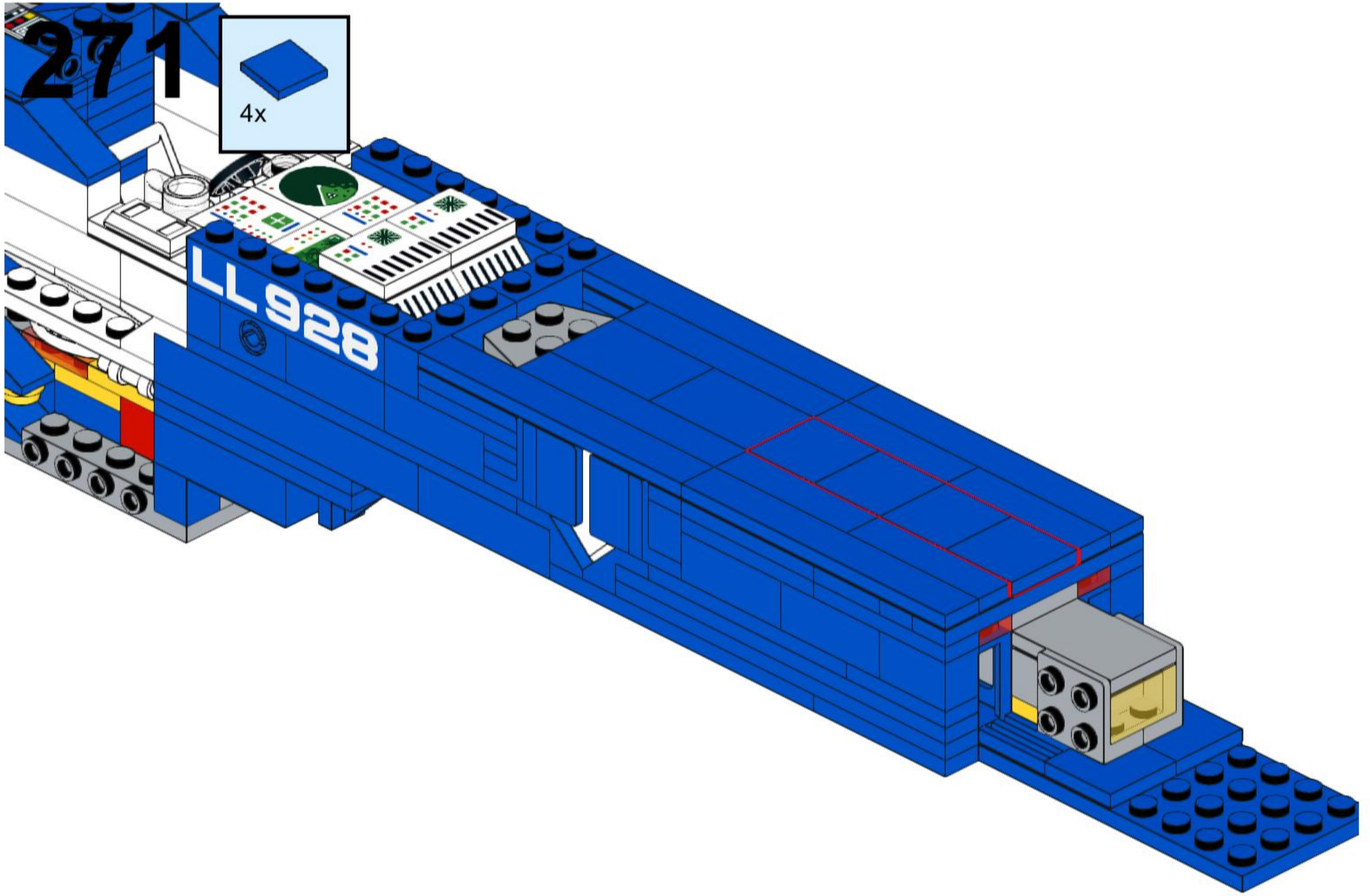

272

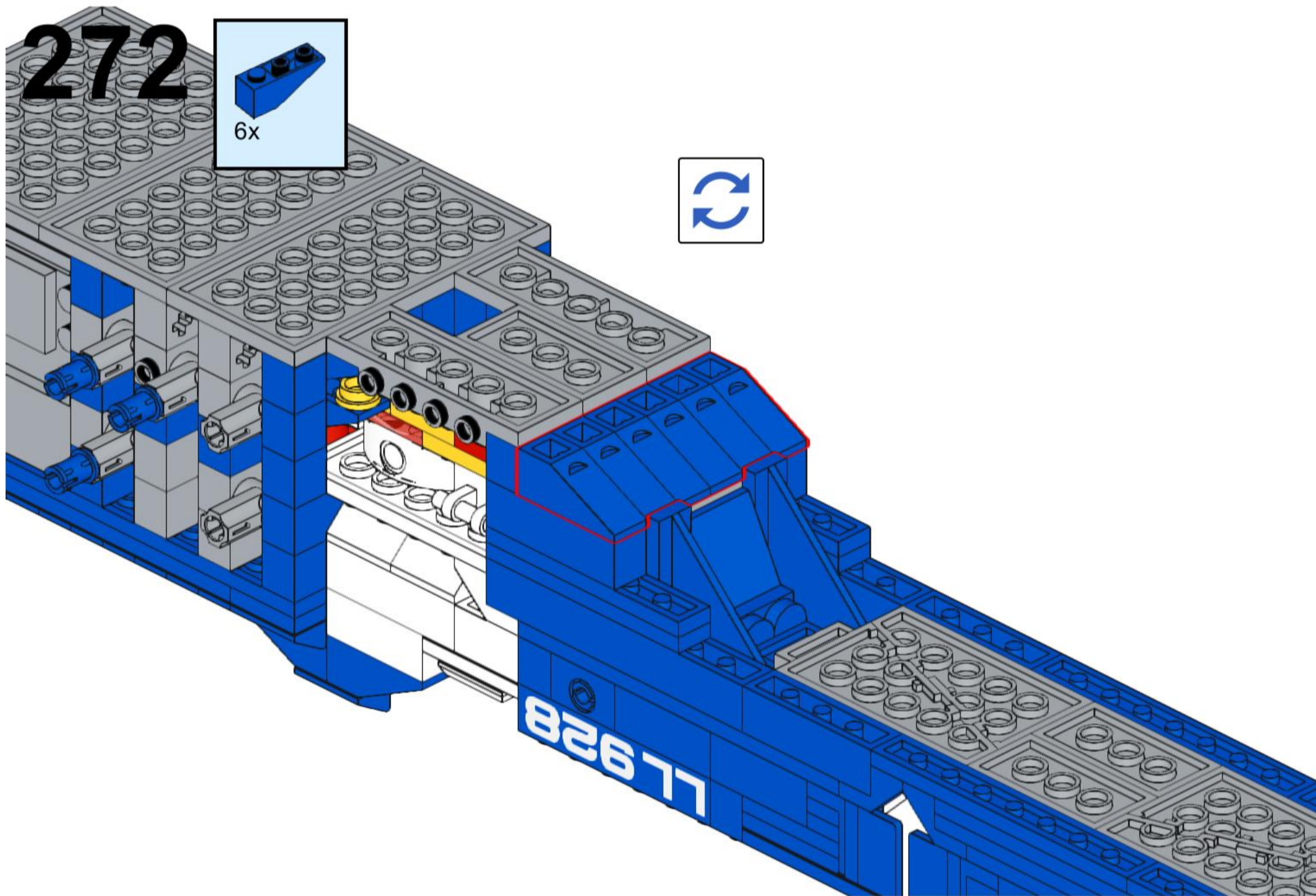
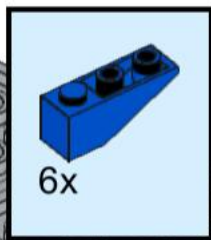

273

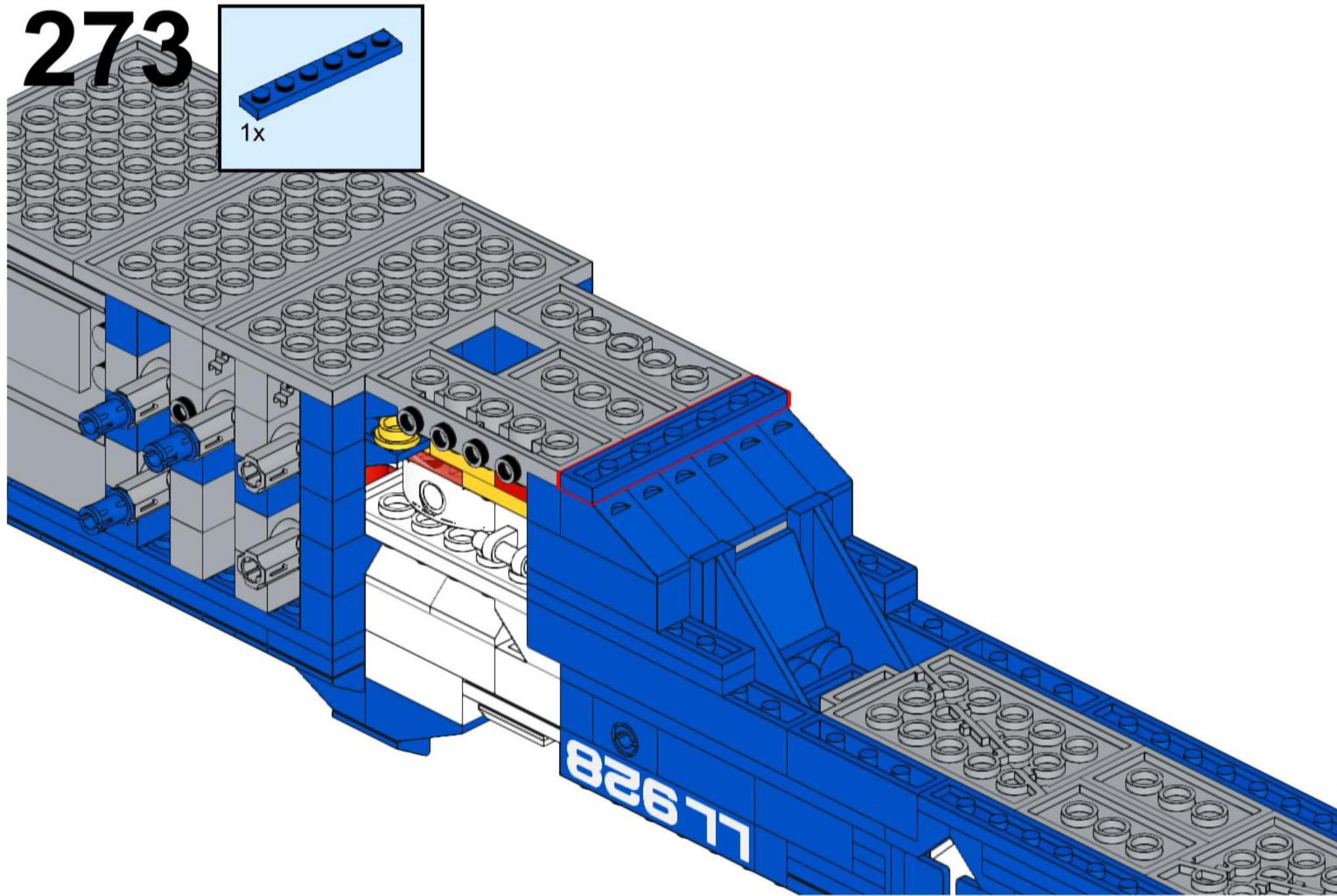
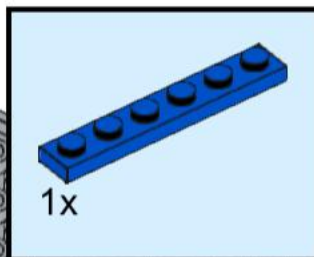

274

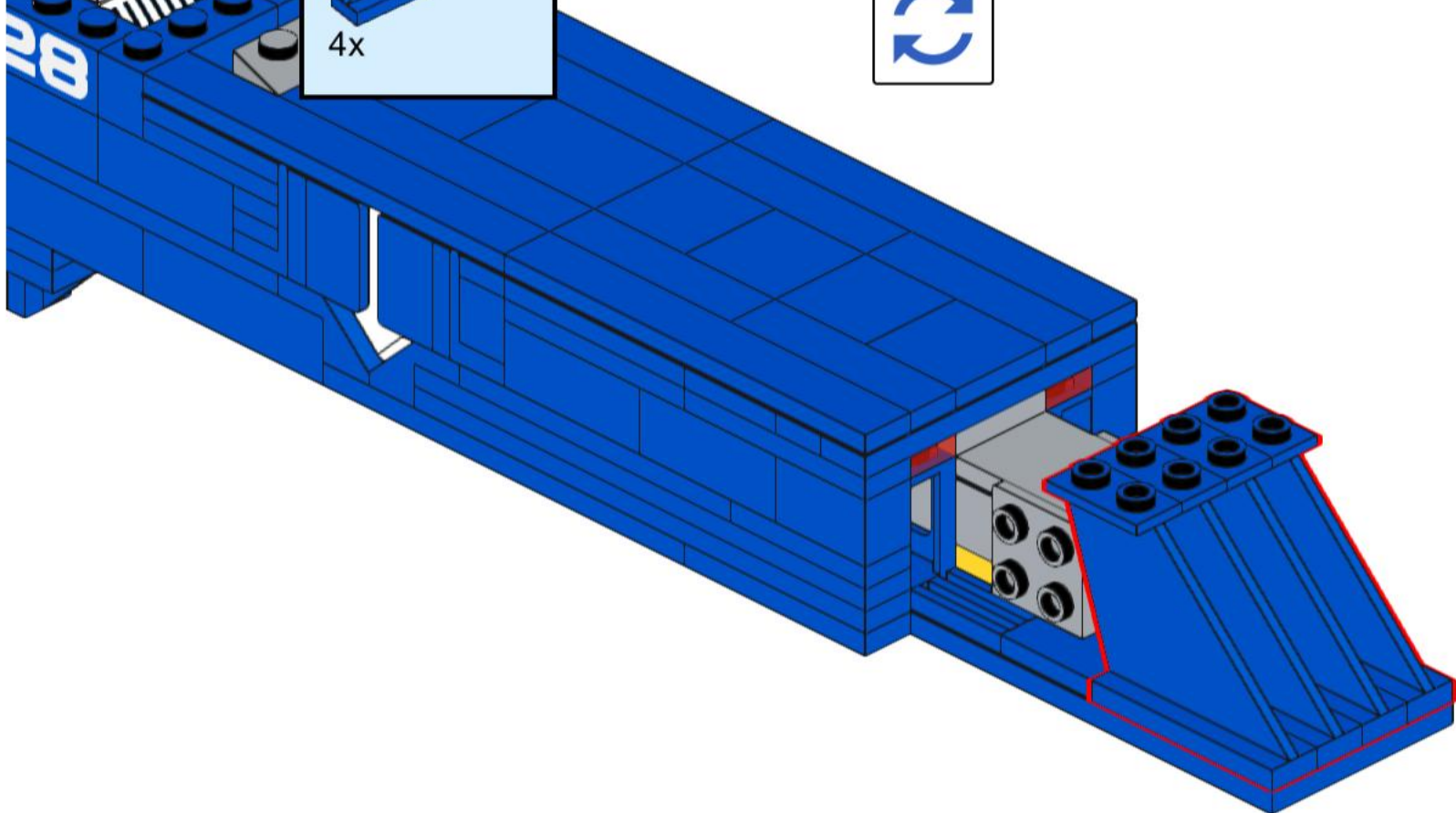
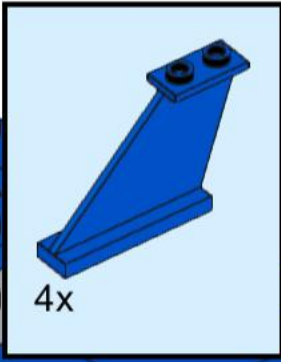

275

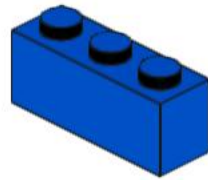
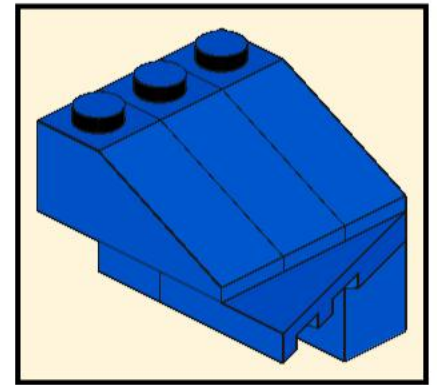
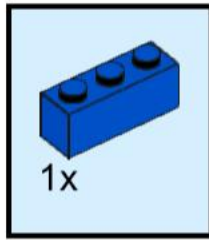

276

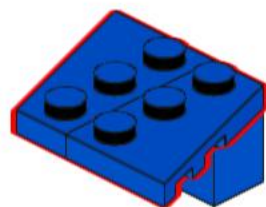
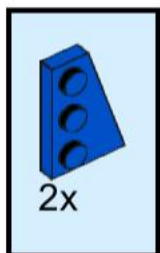

277

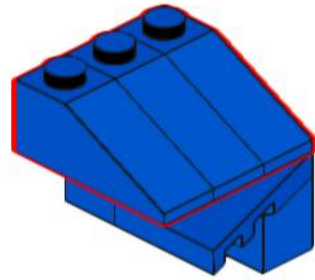
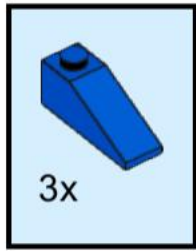

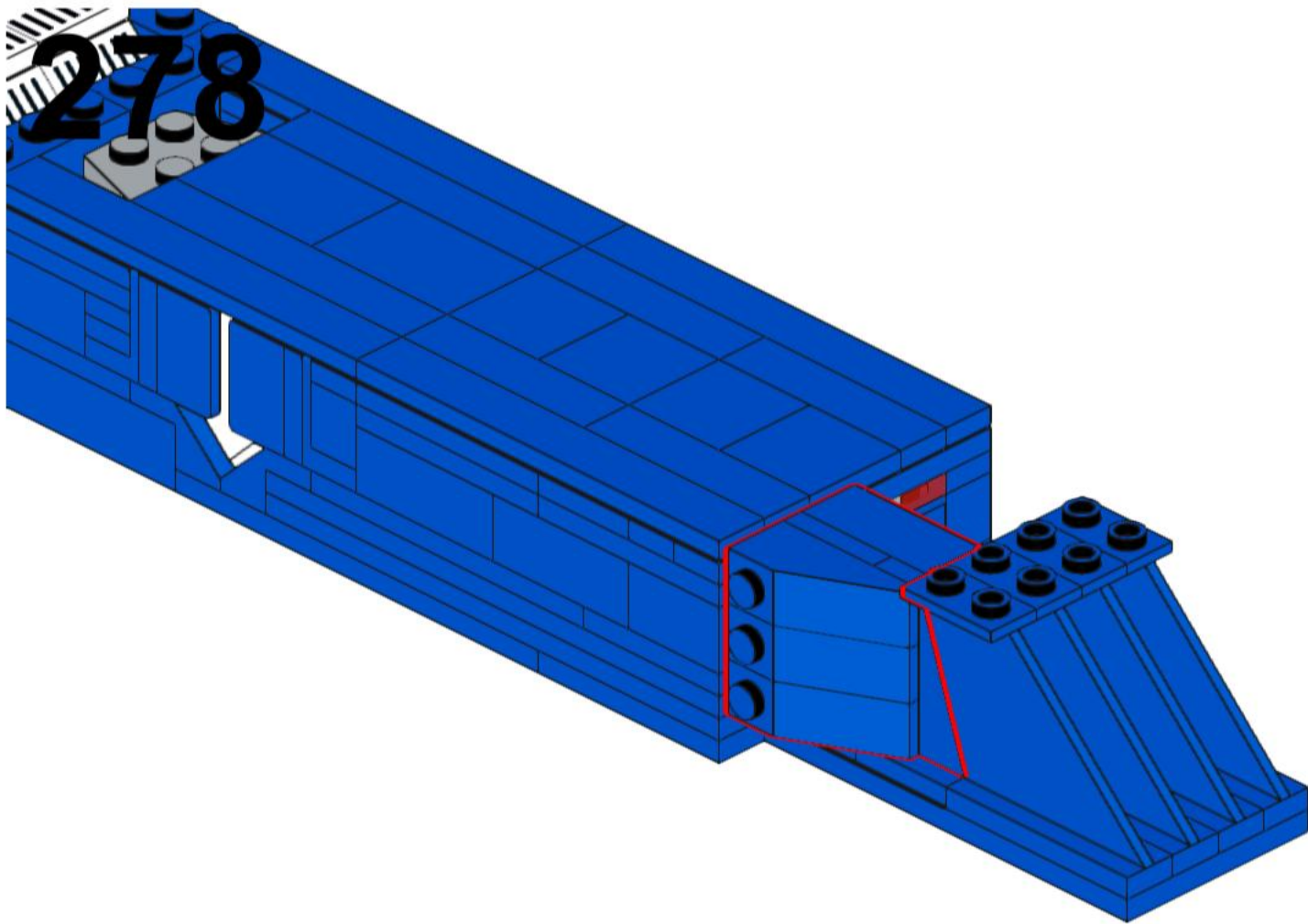

279

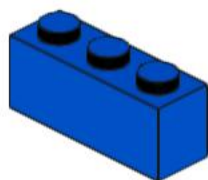
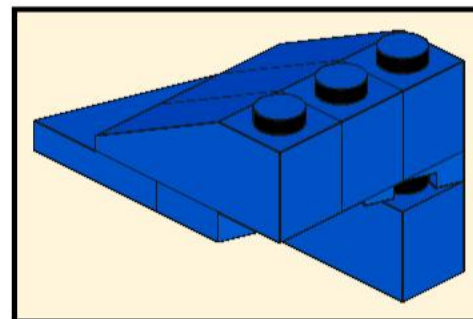
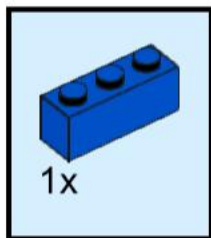

280

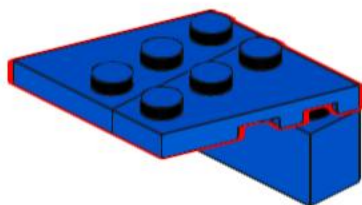
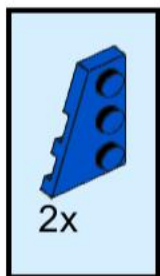

281

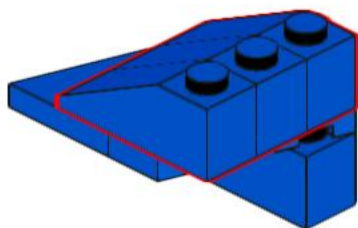
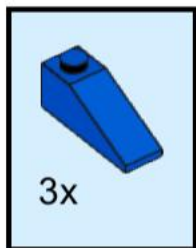

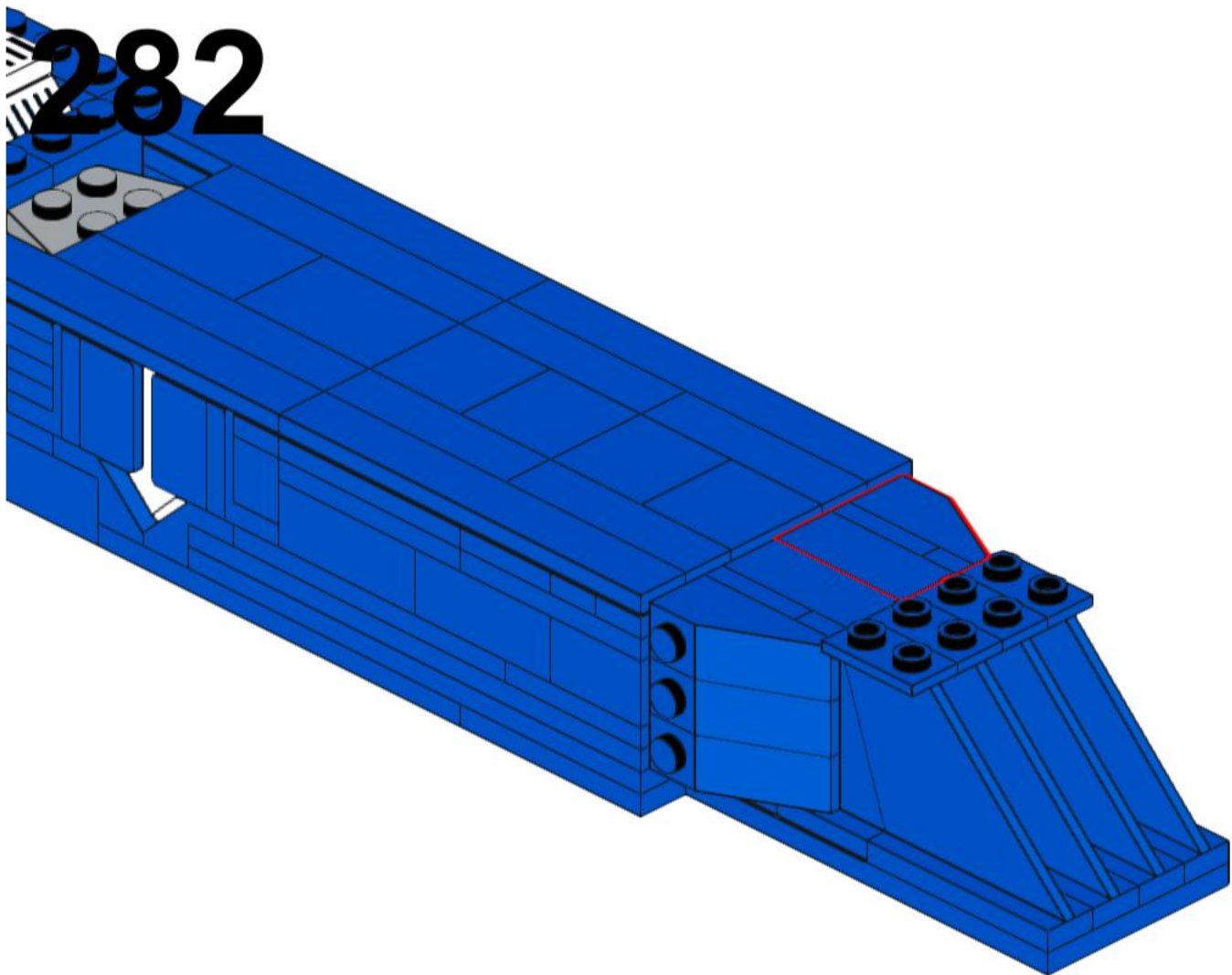

282

283

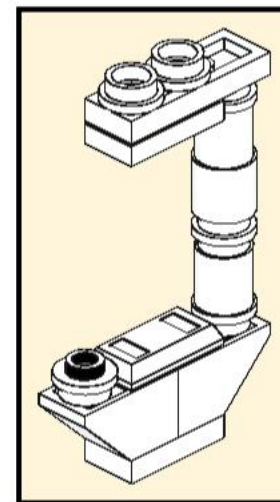
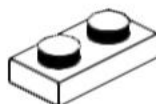
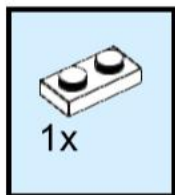

284

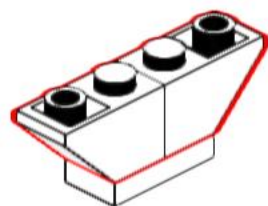
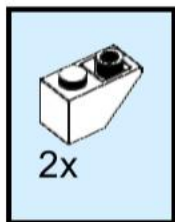

285

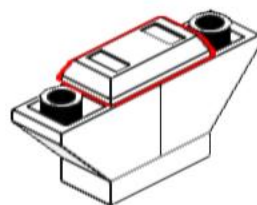
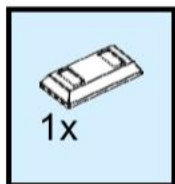

286

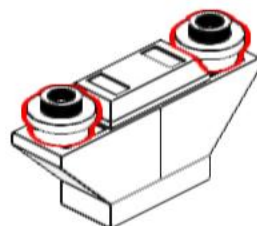

287

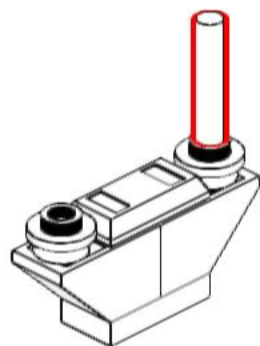
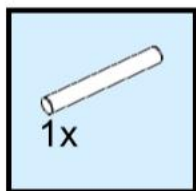

288

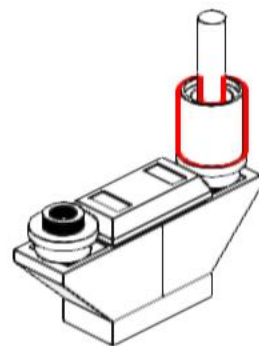
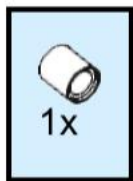

289

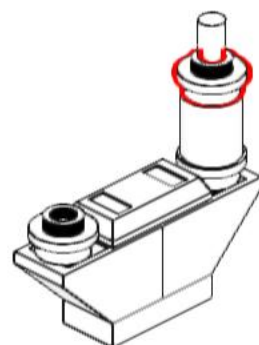

290

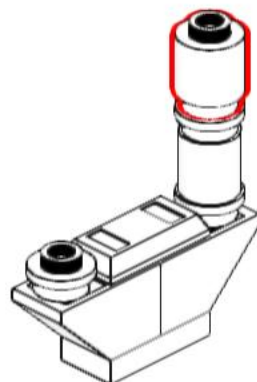
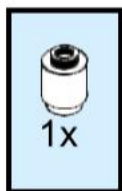

291

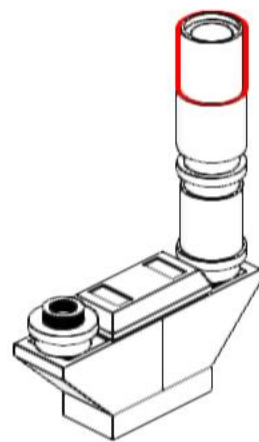
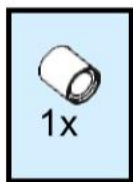

292

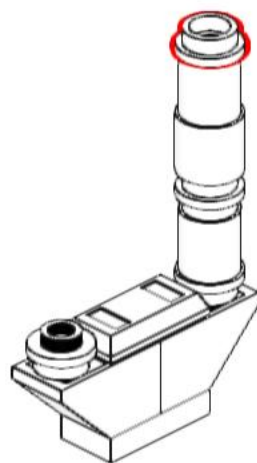

293

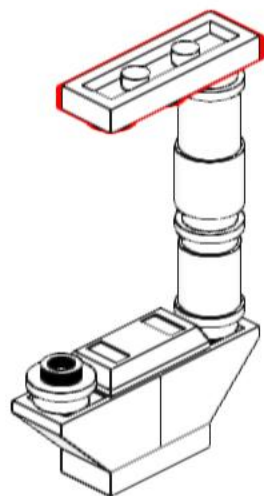
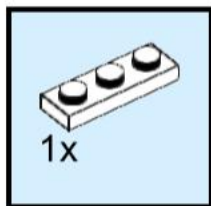

294

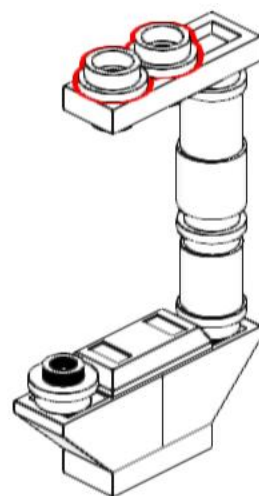

295

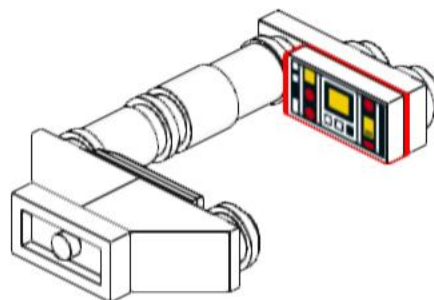
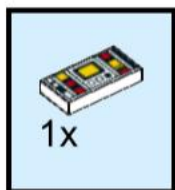

296

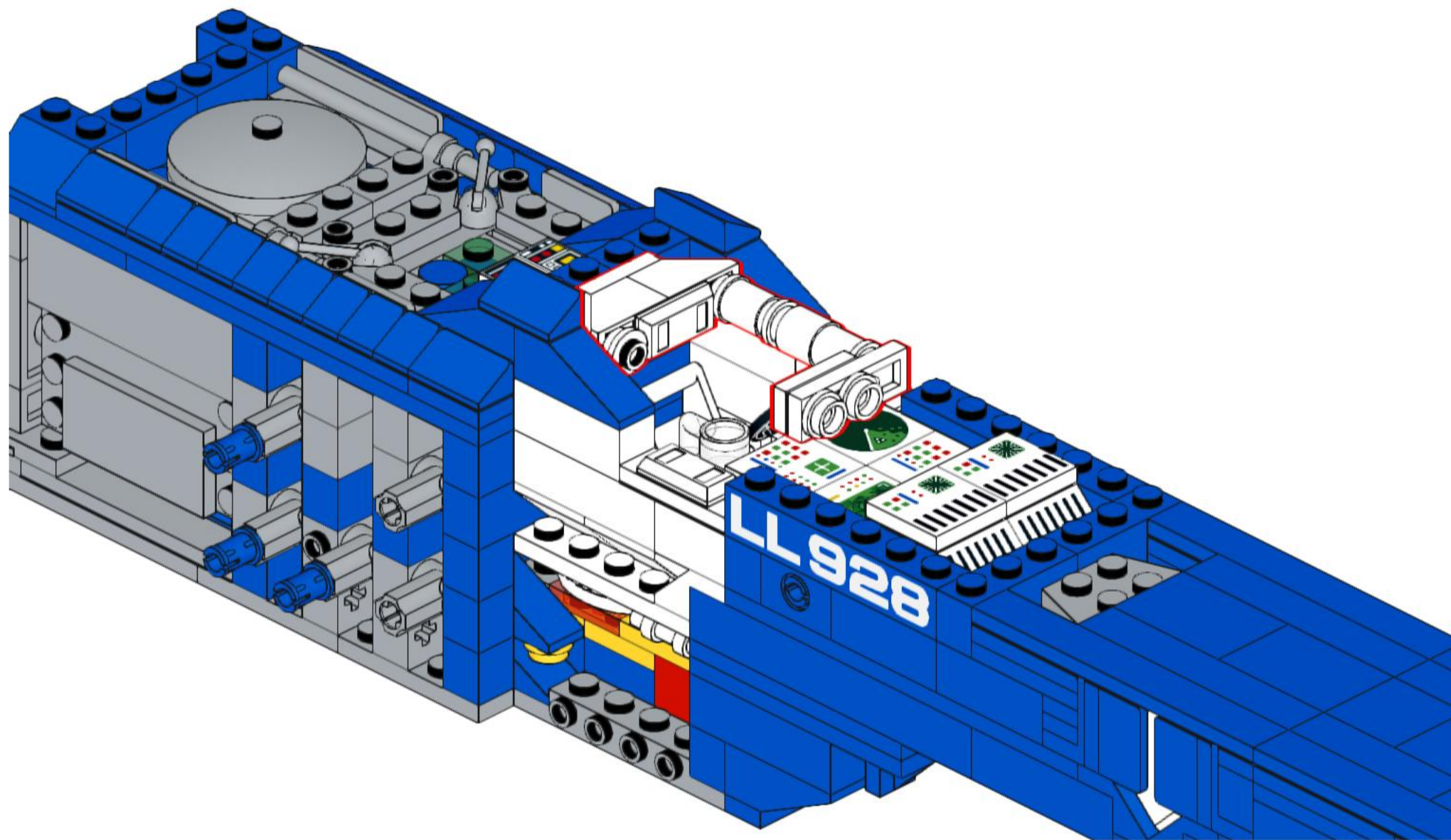

297

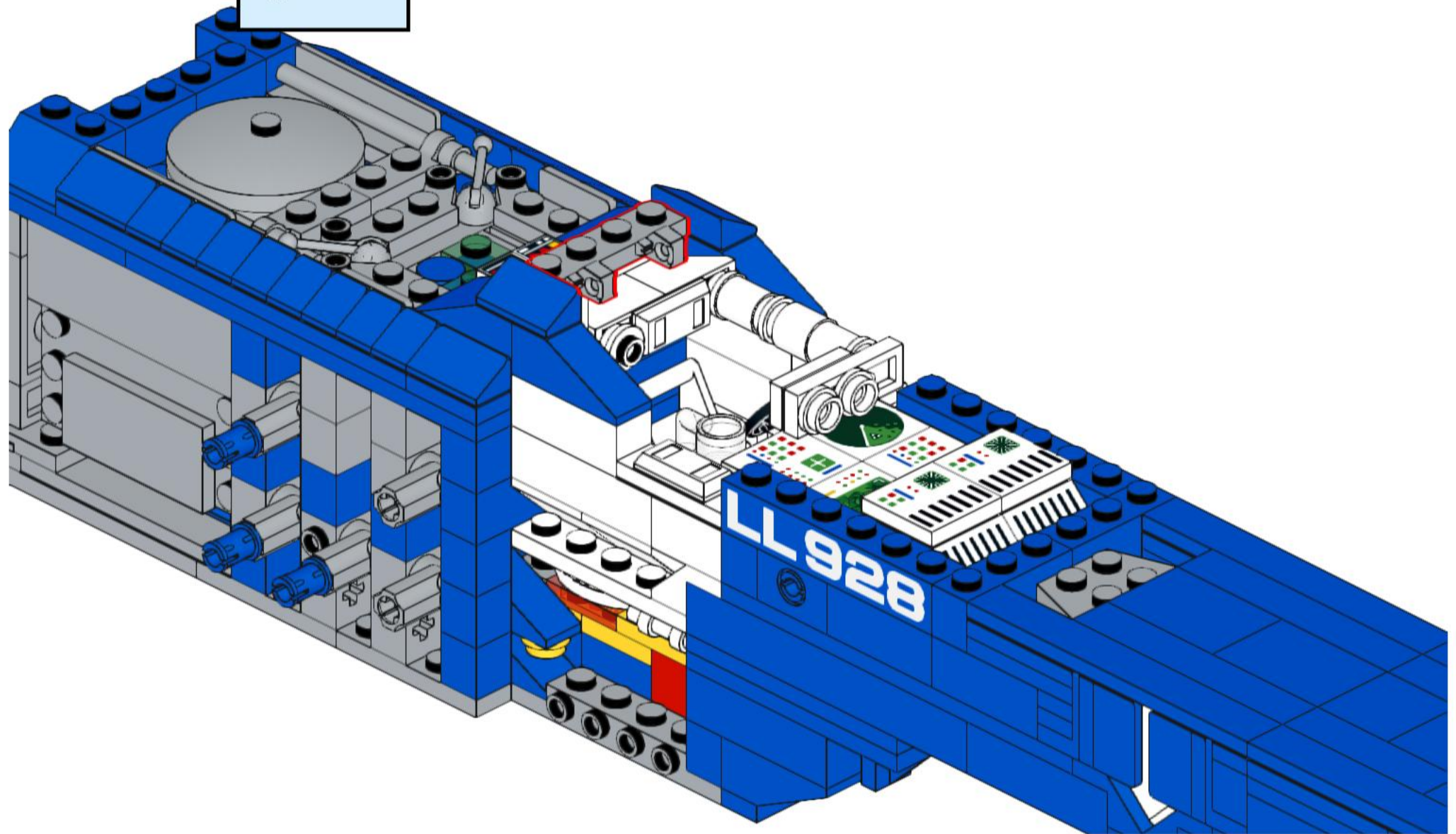
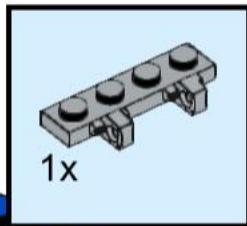

298

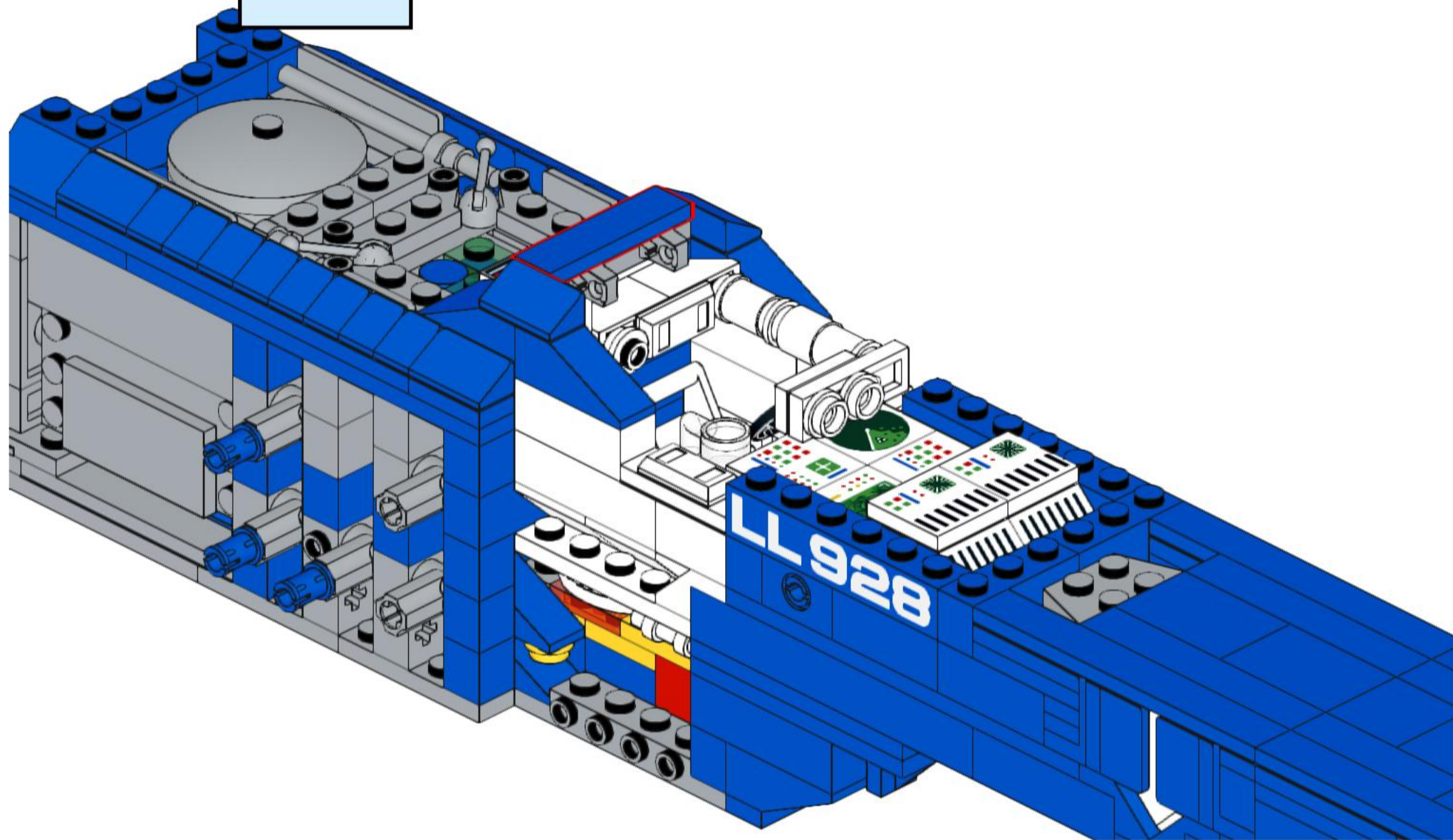
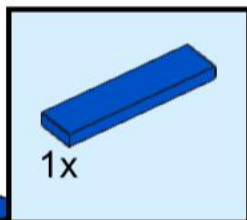

299

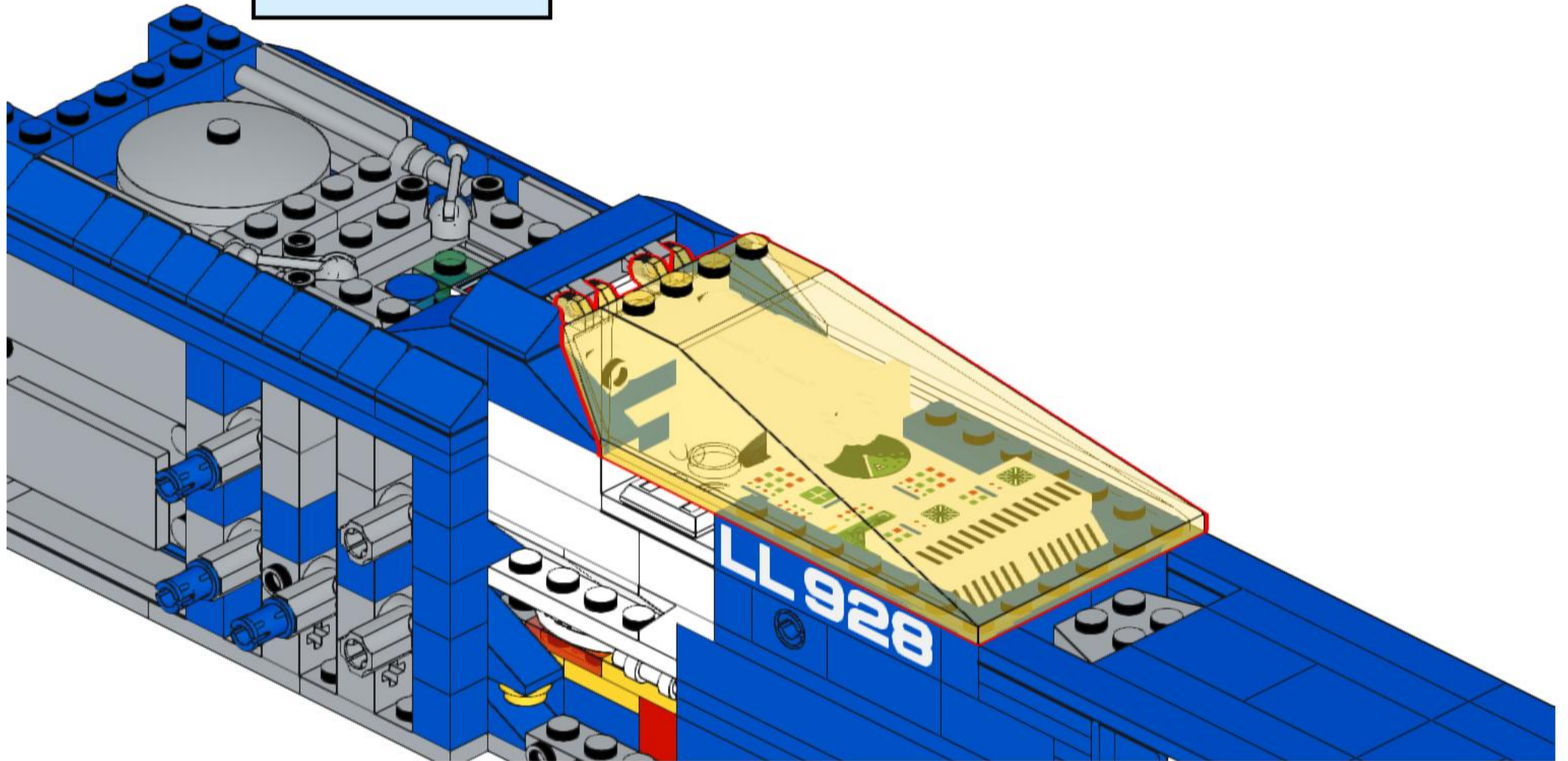
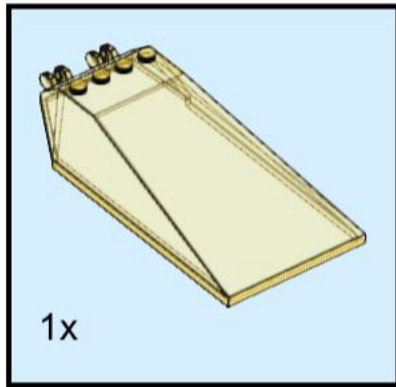

300

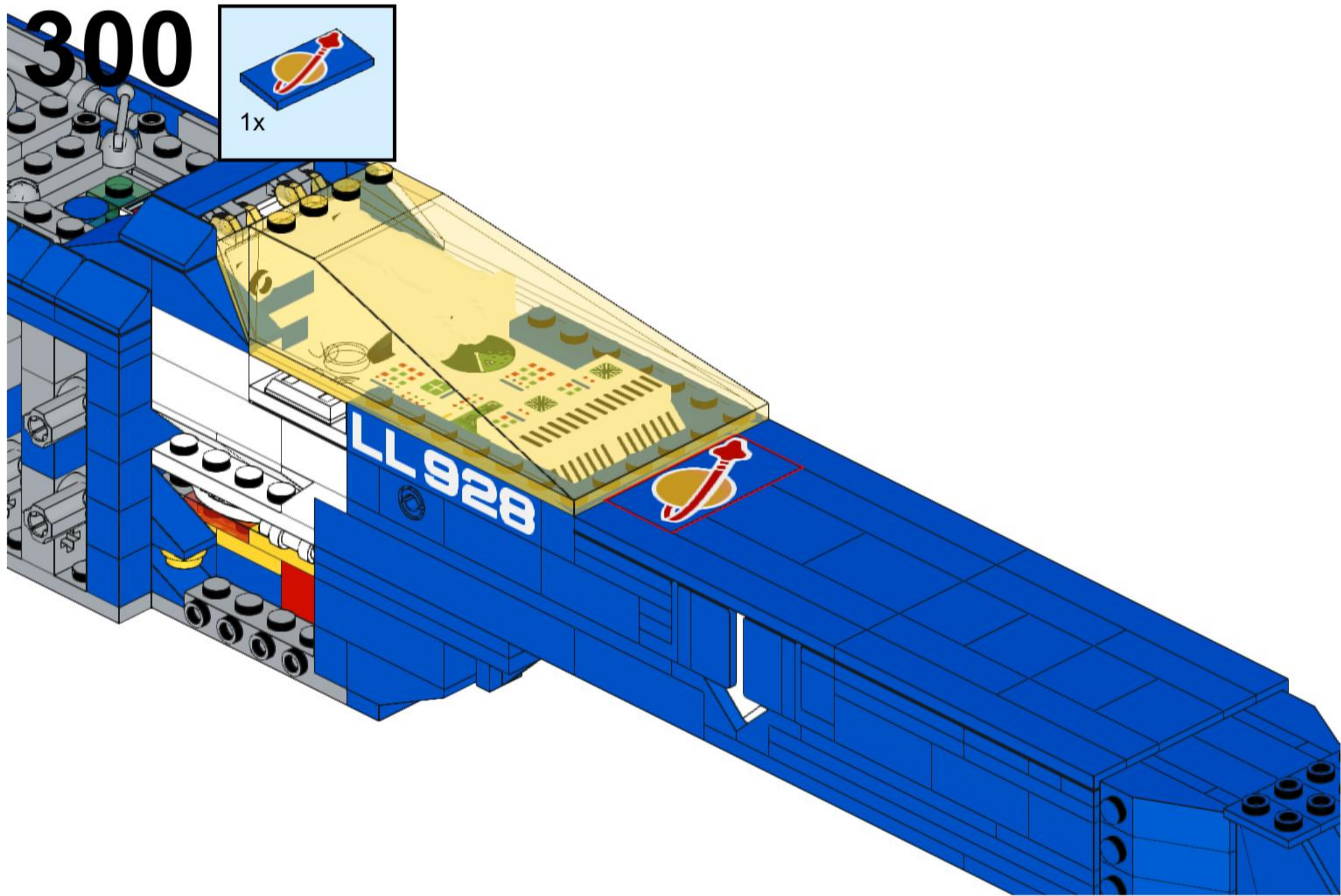
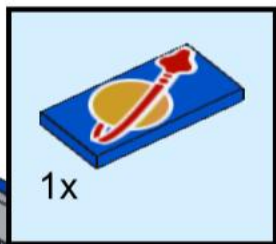

301

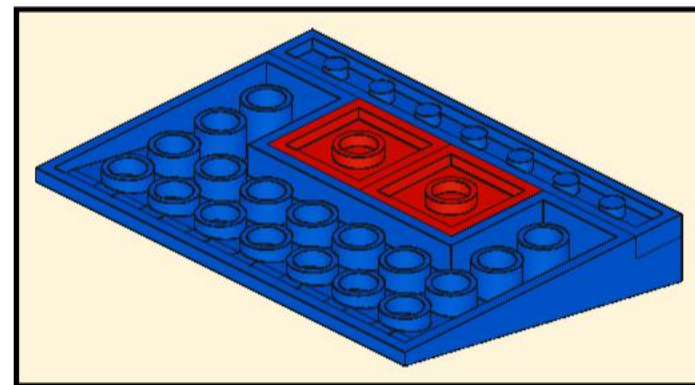
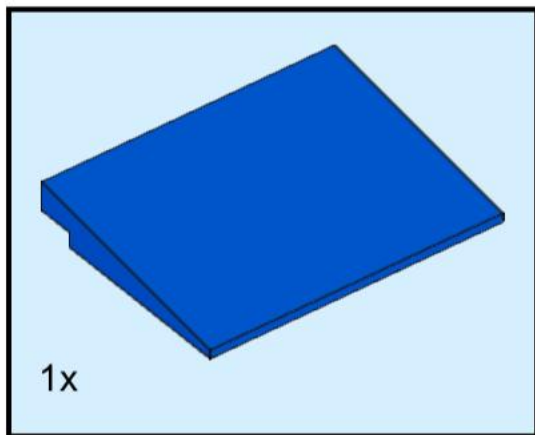

2x

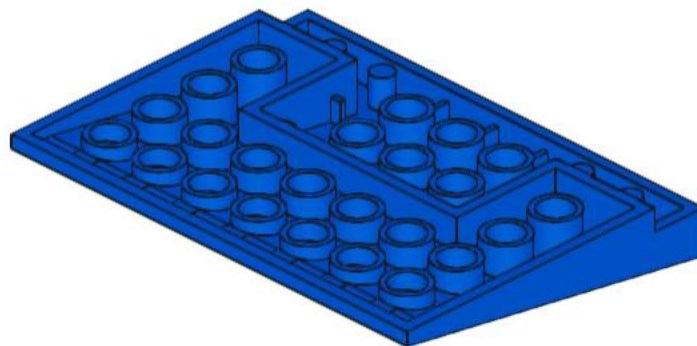

302

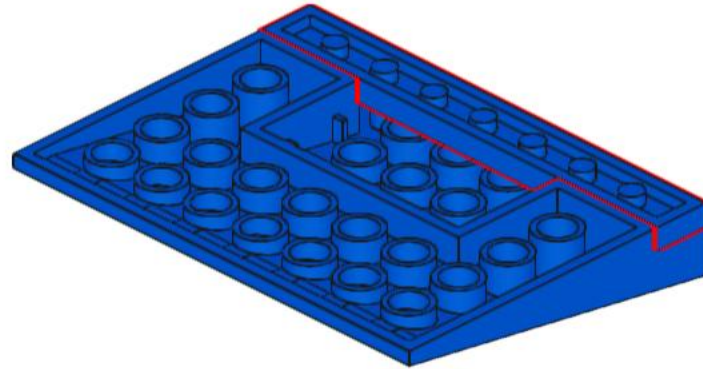
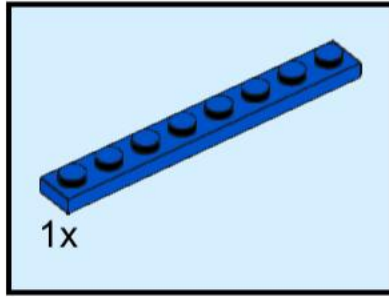

303

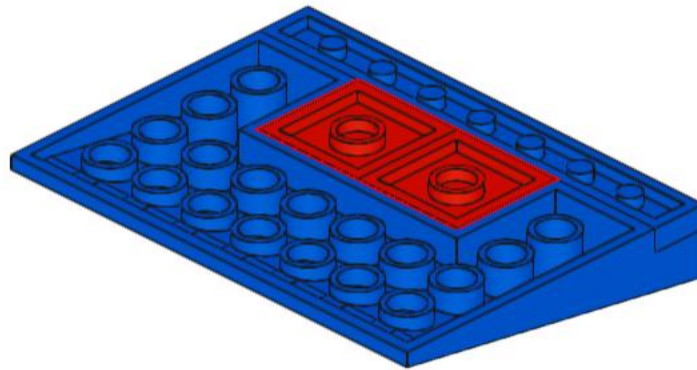
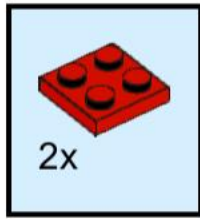

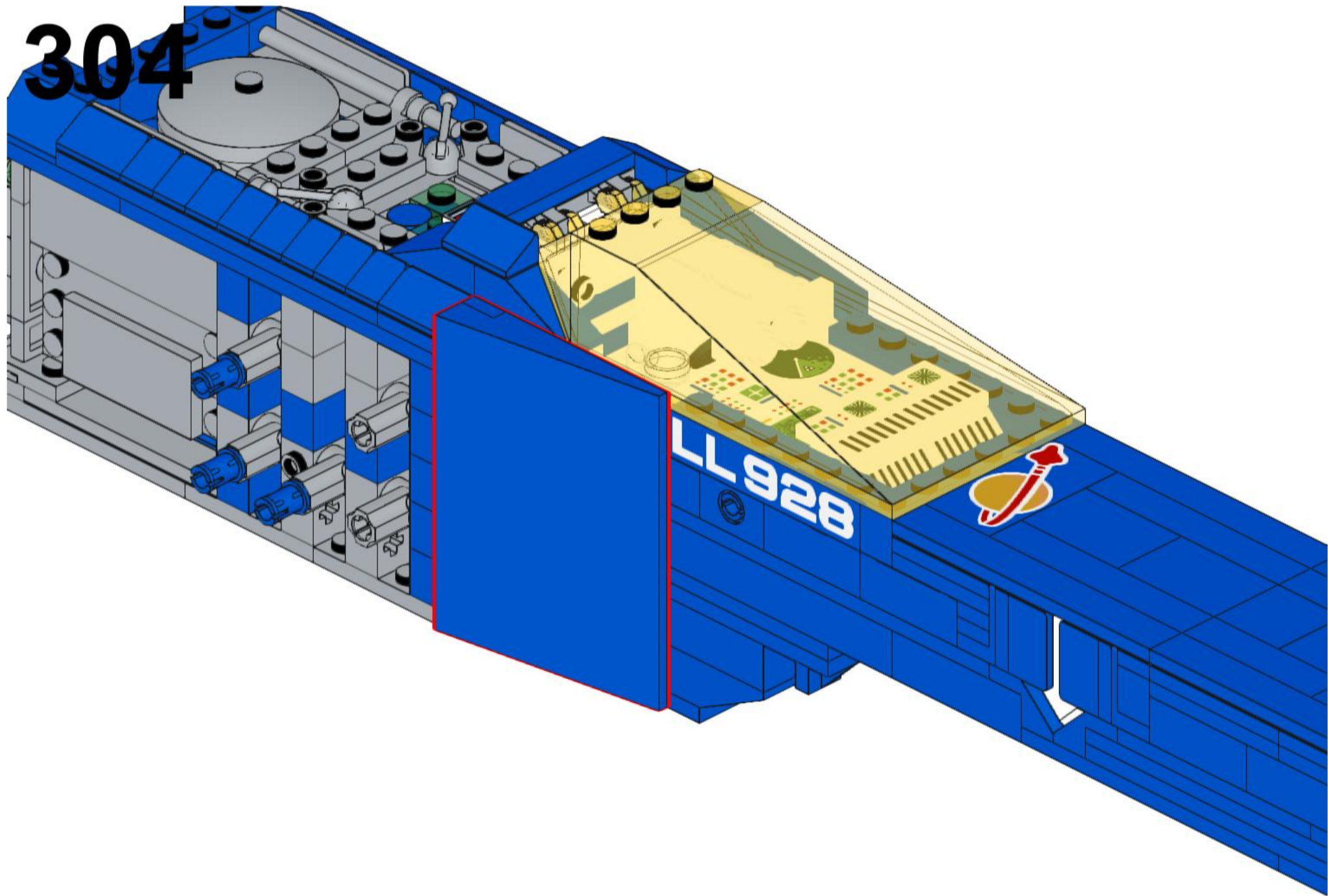

305

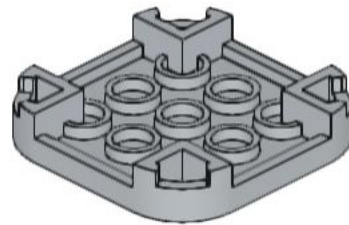
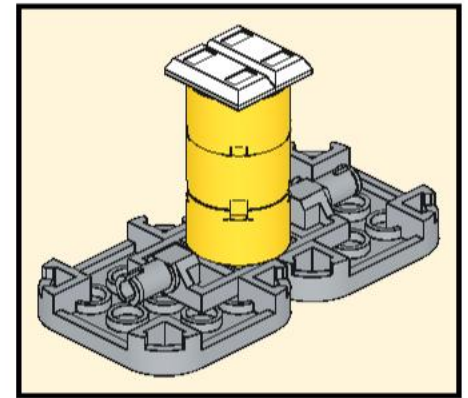
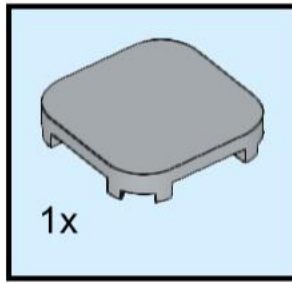

306

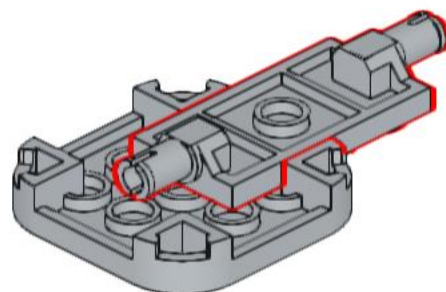
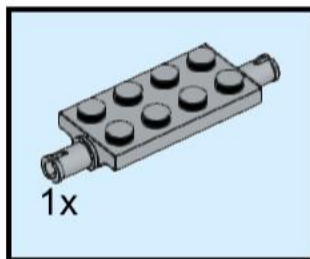

307

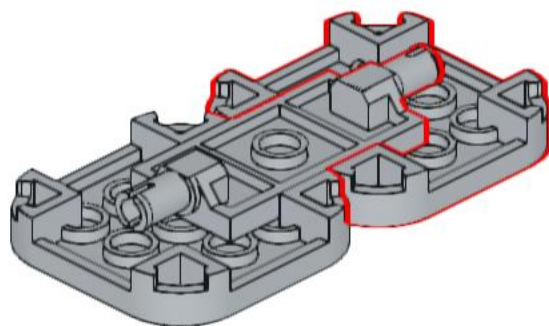
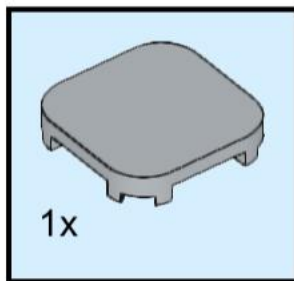

308

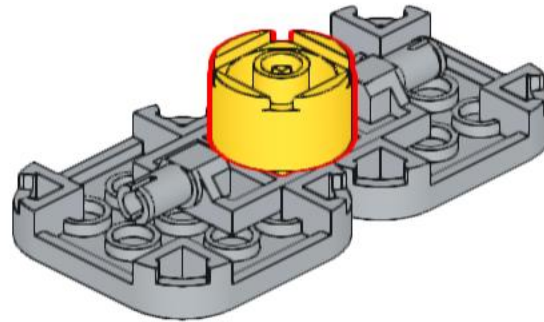
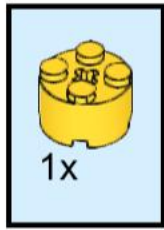

309

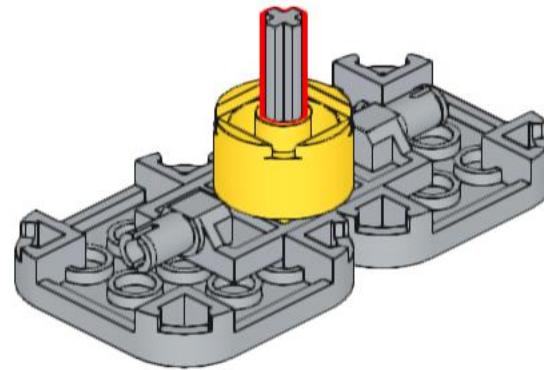
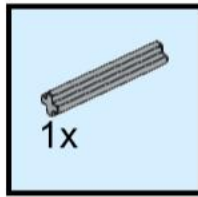

310

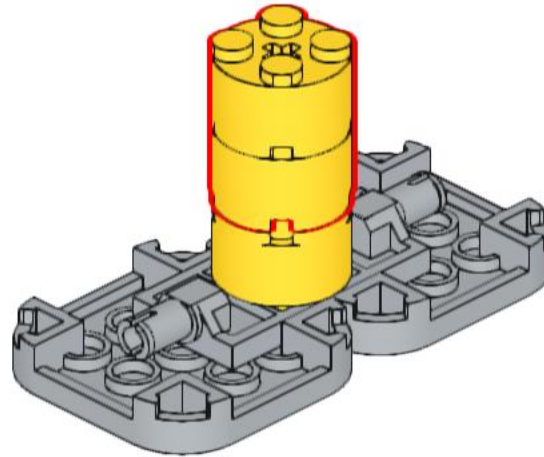
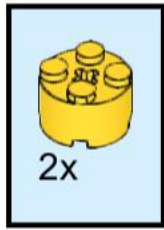

311

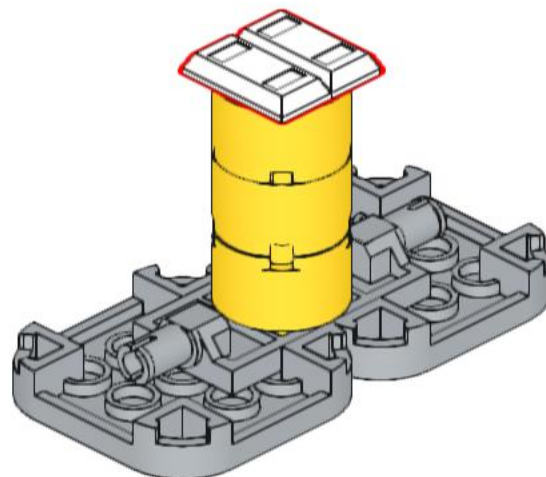
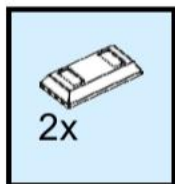

312

This "landing gear" sits inside this hole without connecting with any studs. This hole is also used to connect the display / flight stand which we will make in a separate PDF.

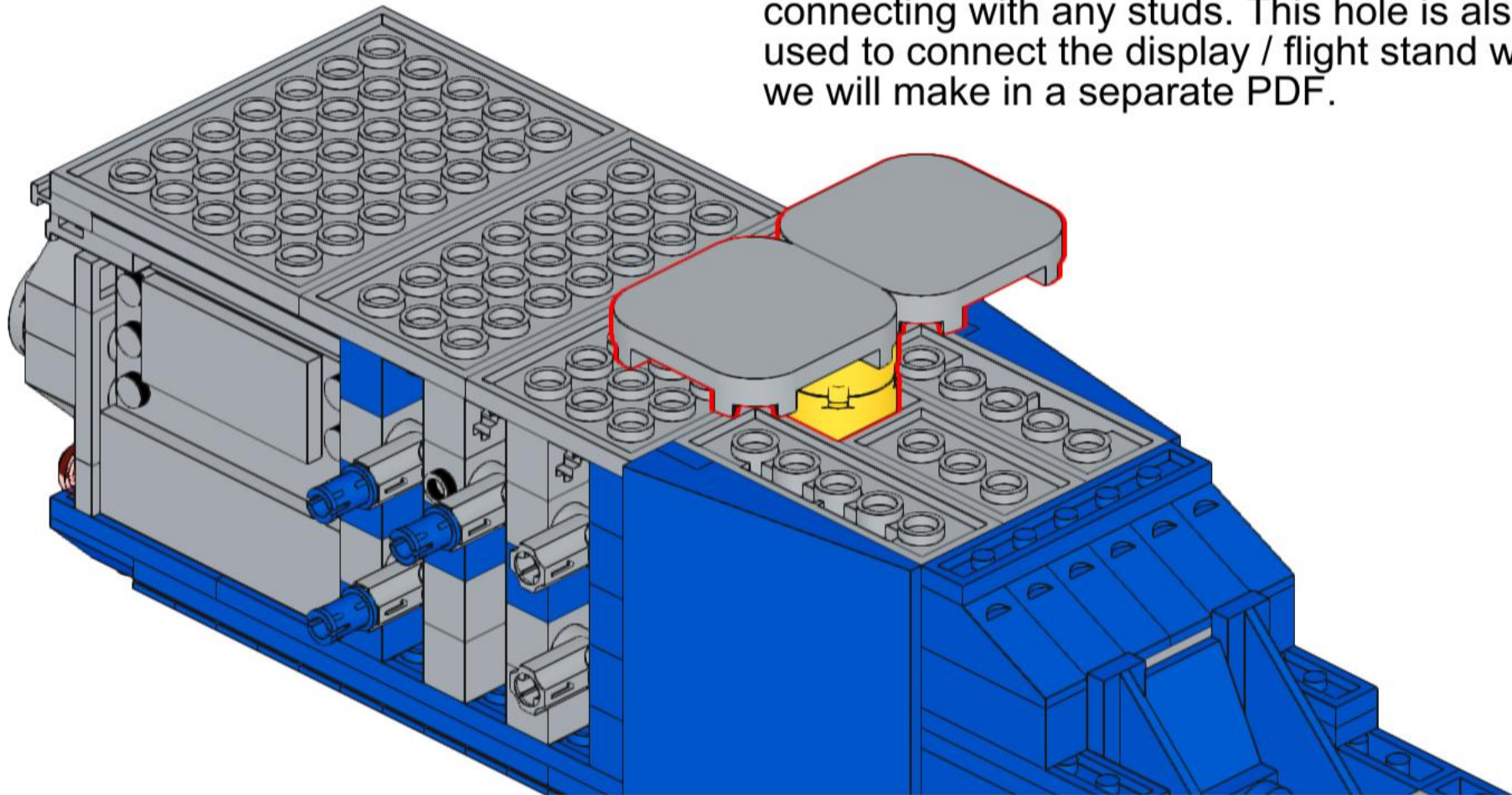

313

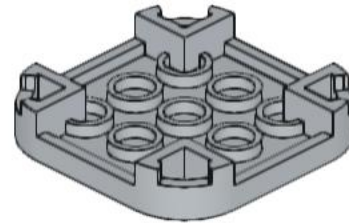
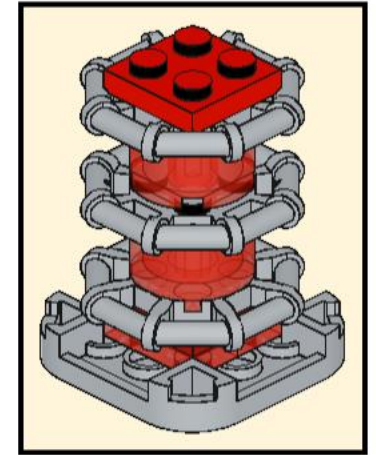
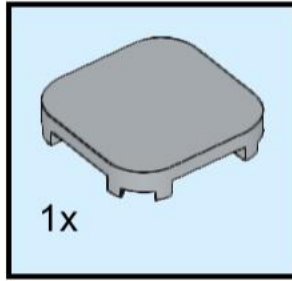

314

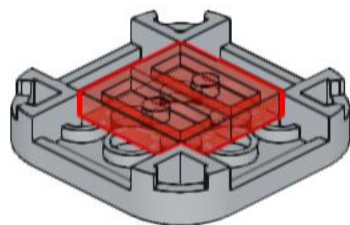
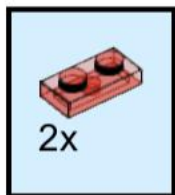

315

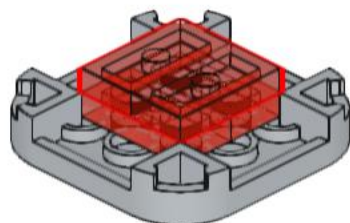
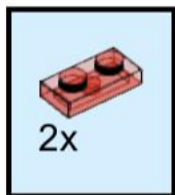

316

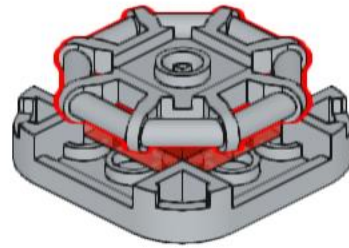
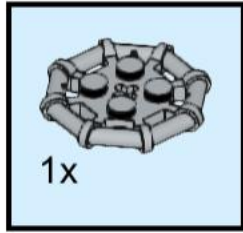

317

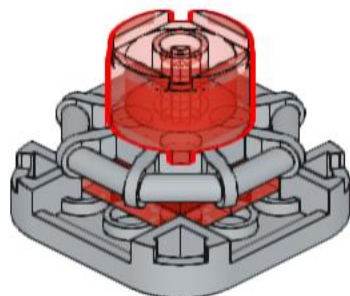
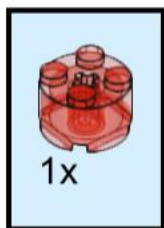

318

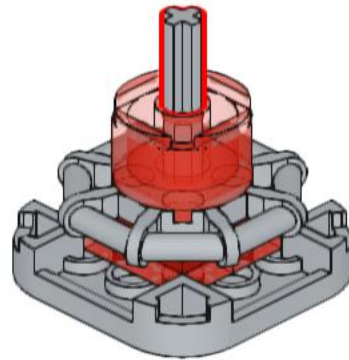
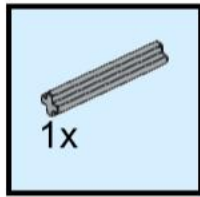

319

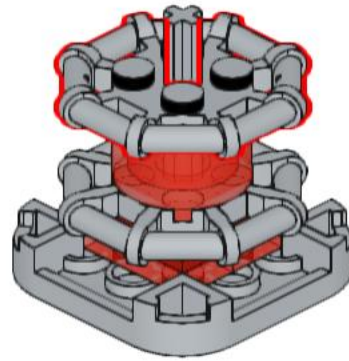
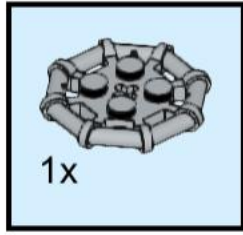

320

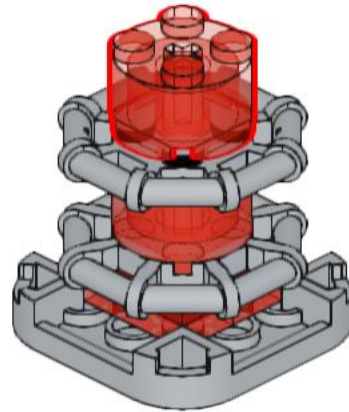
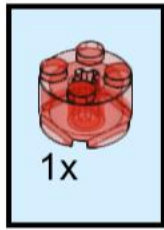

321

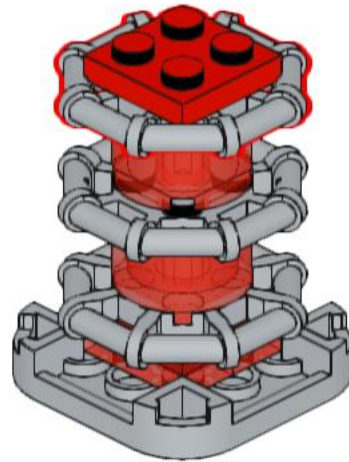
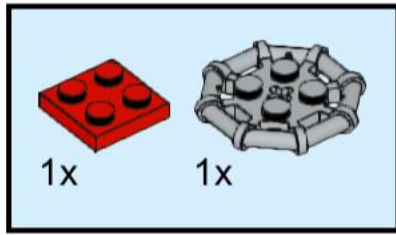

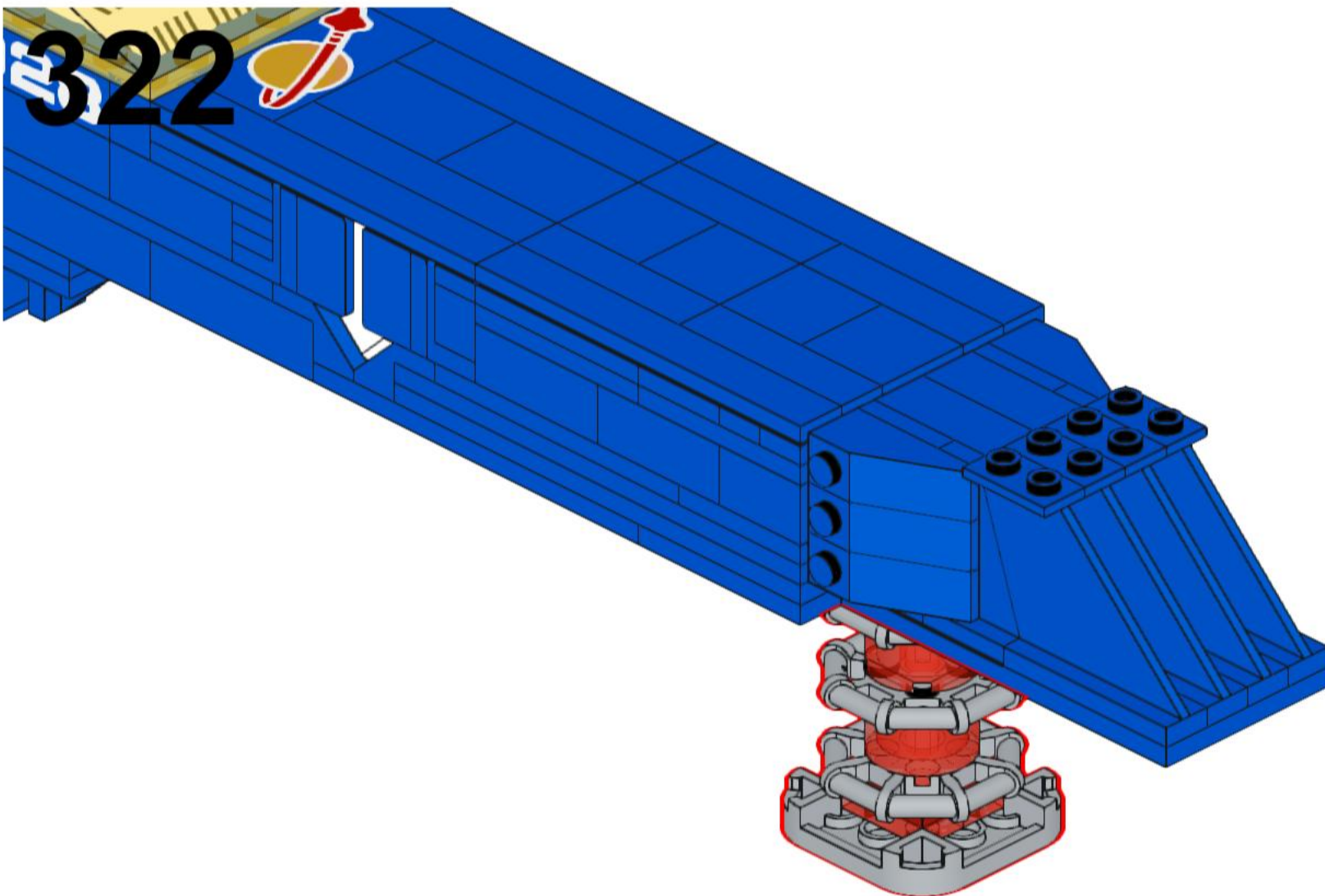

323

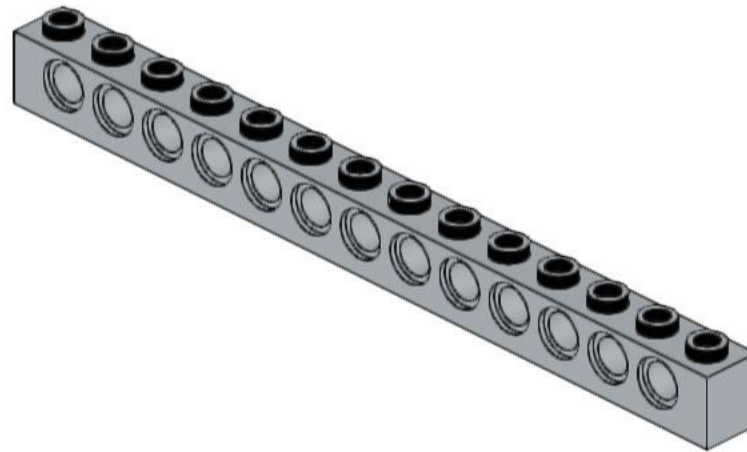
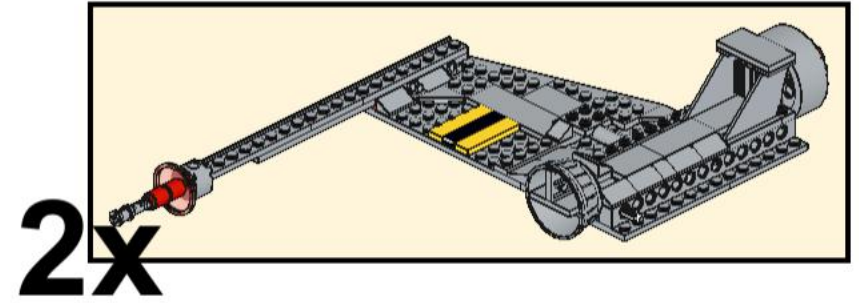
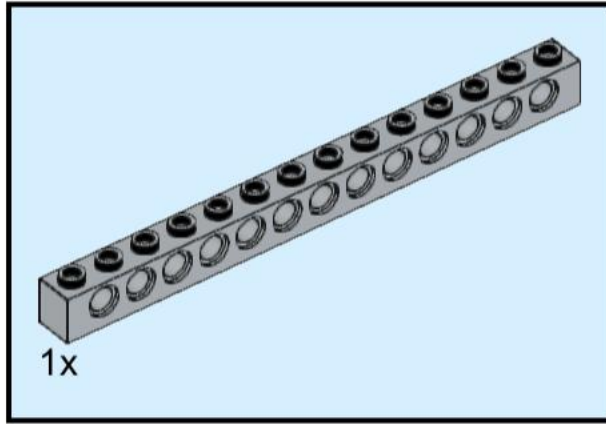

324

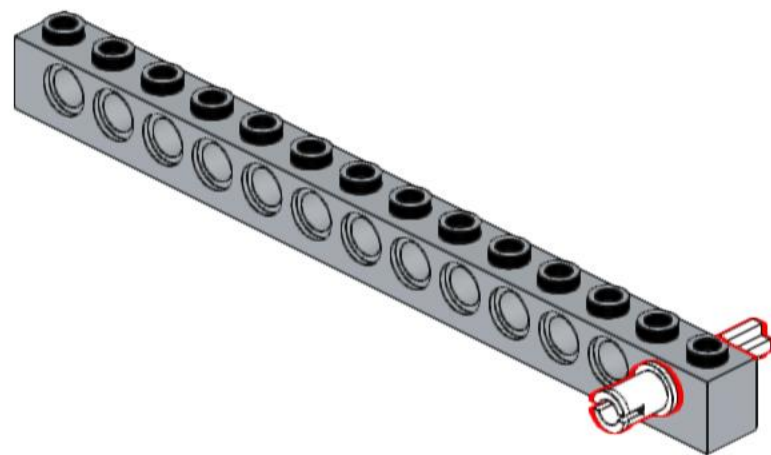
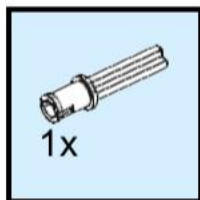

325

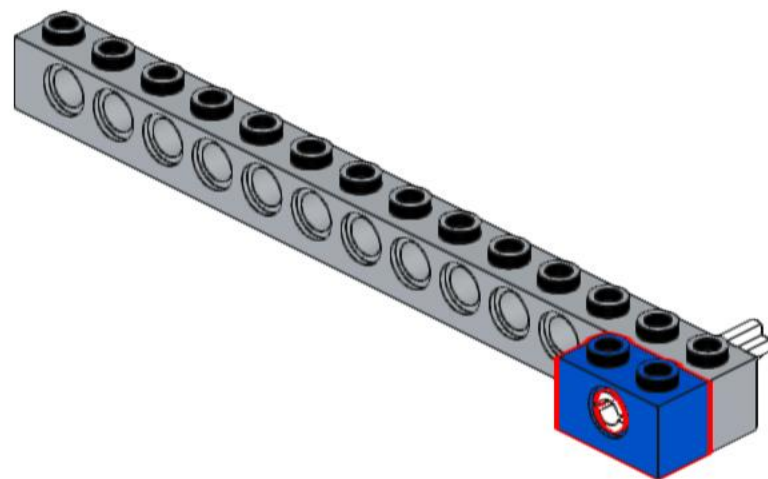
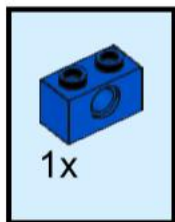

326

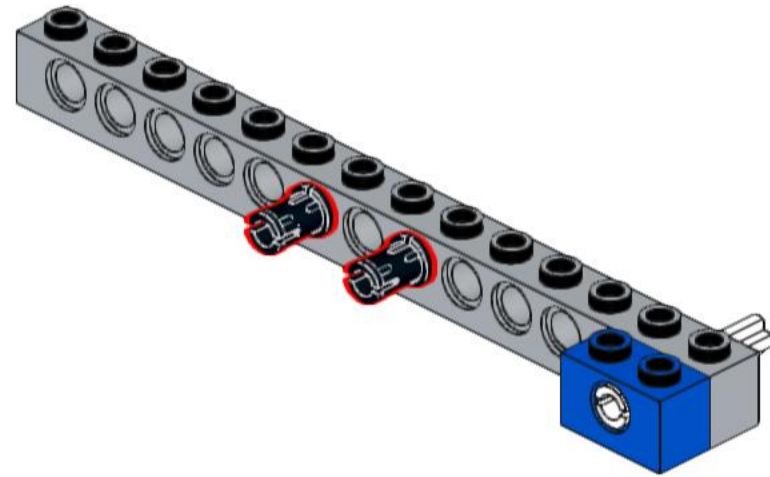

327

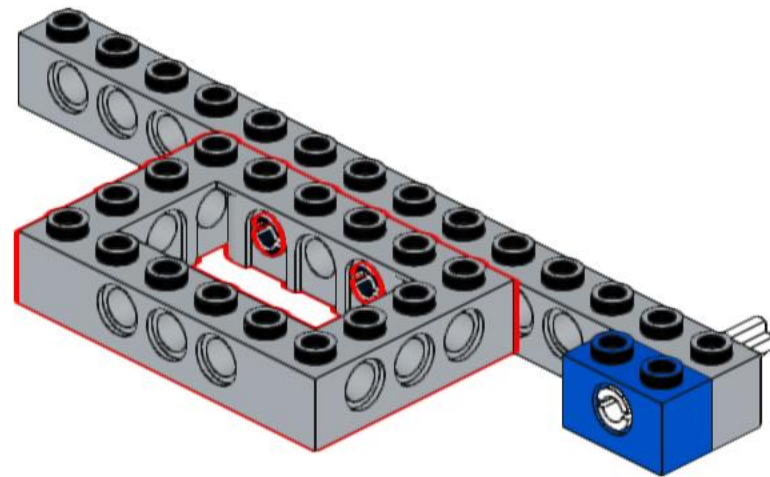
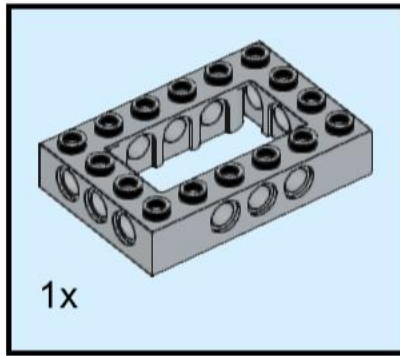

328

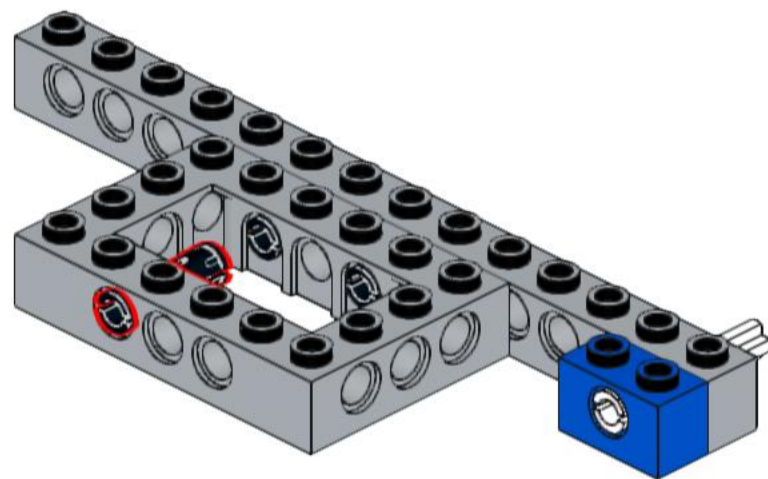

329

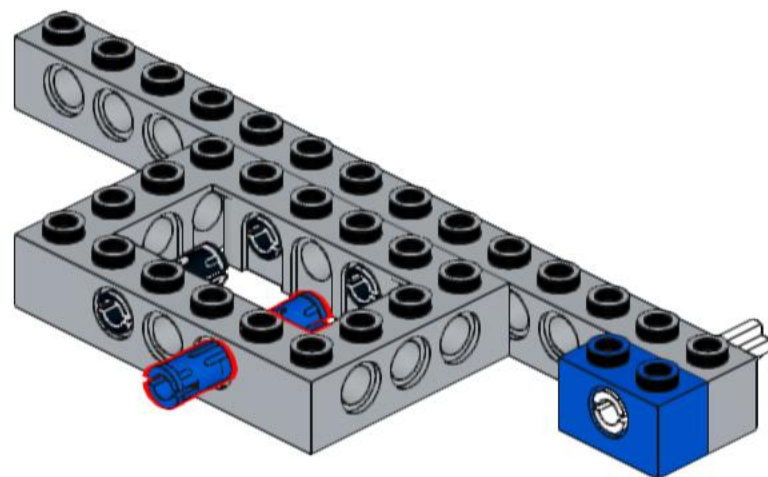
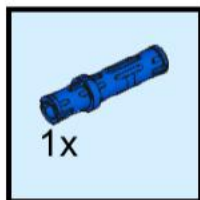

330

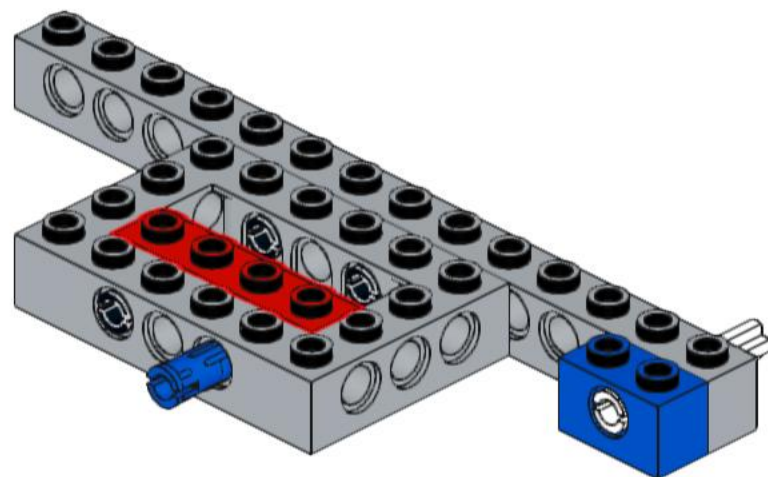
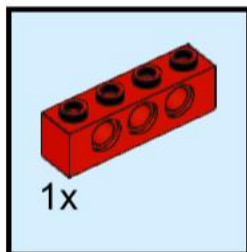

331

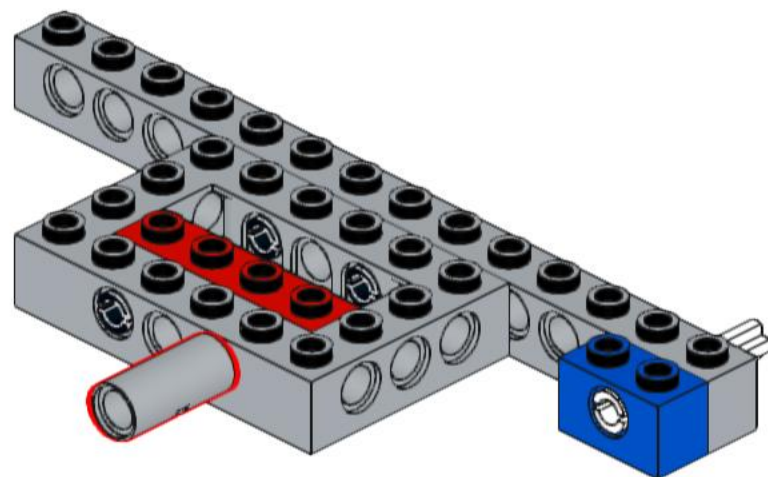
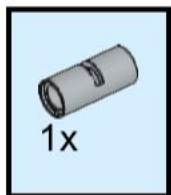

332

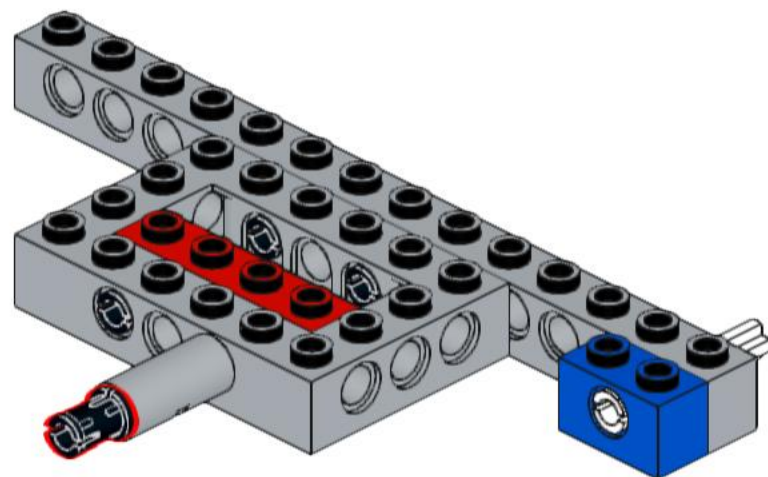
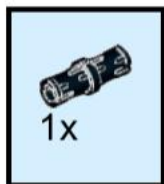

333

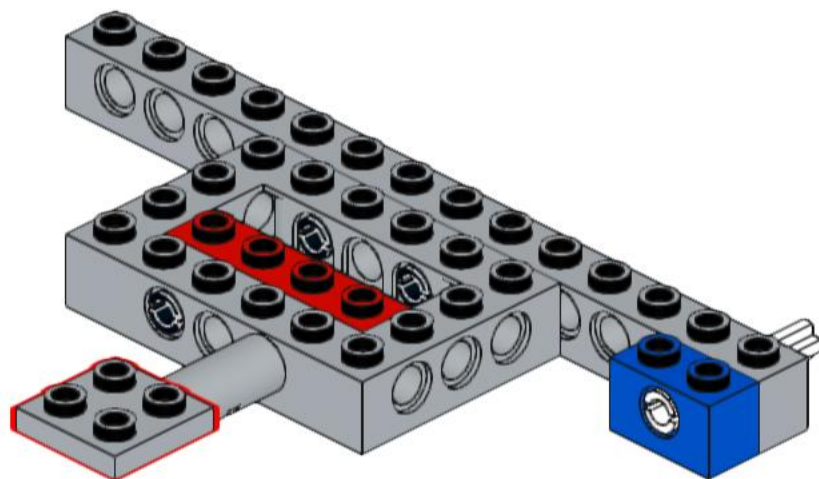
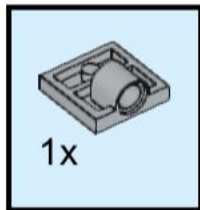

334

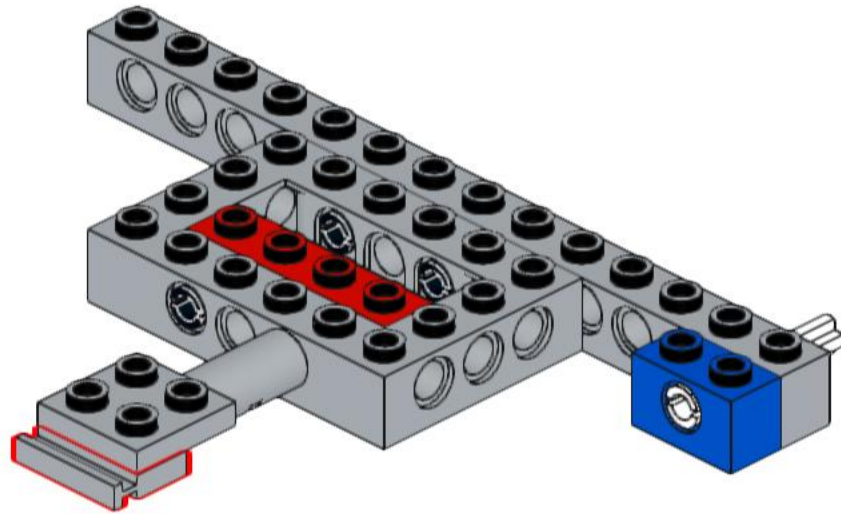
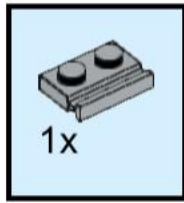

335

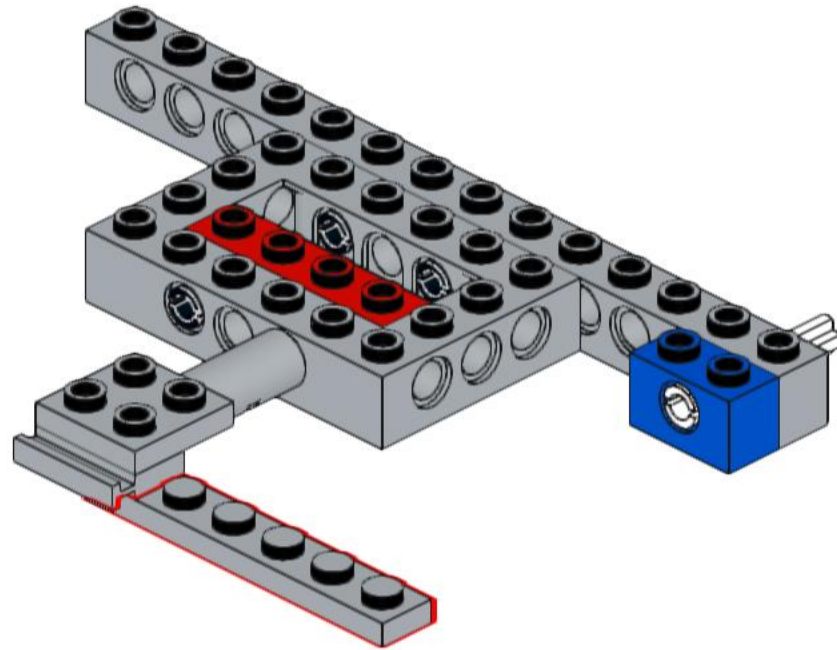
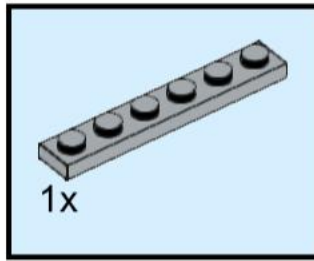

336

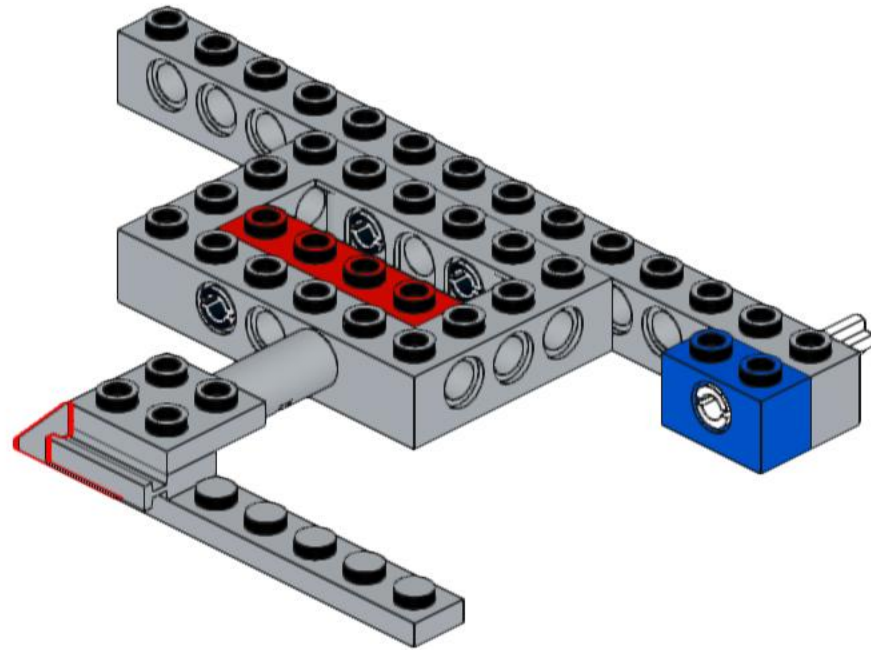
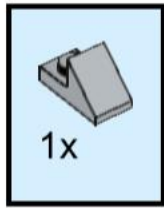

337

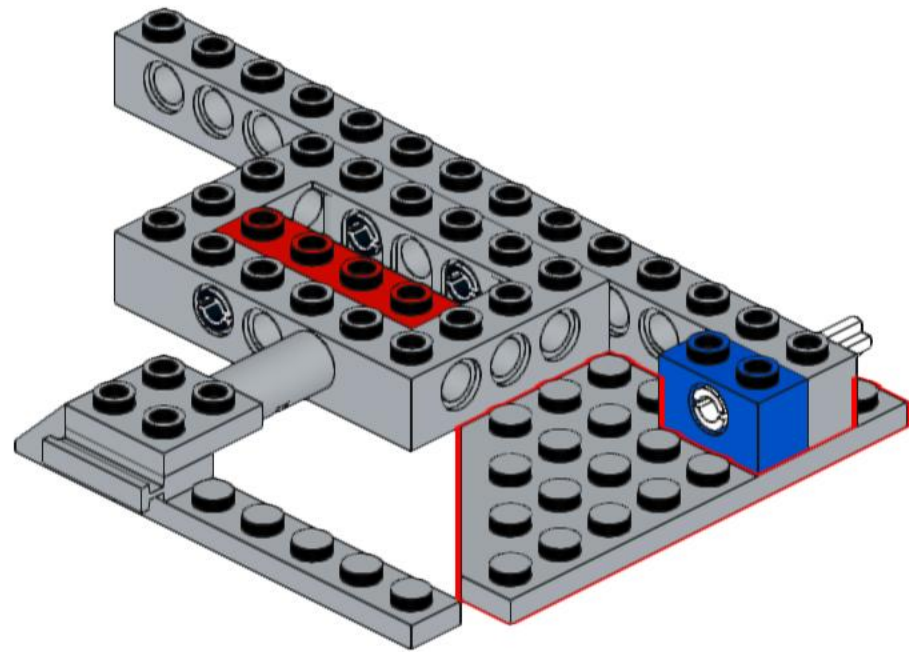
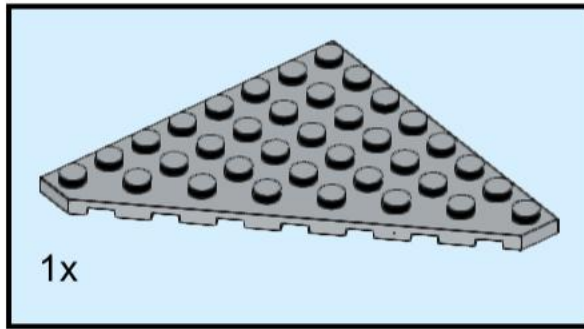

338

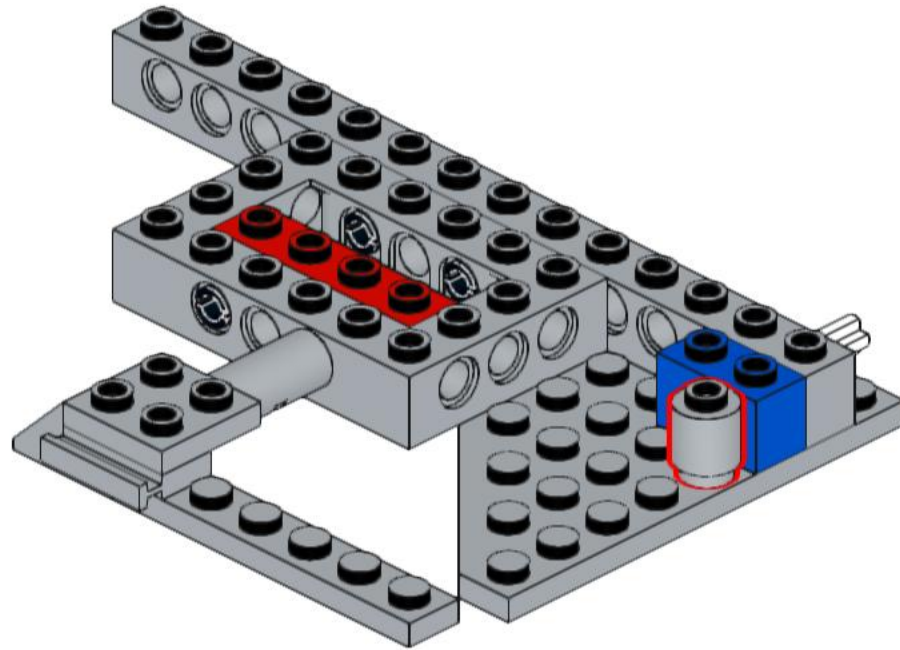
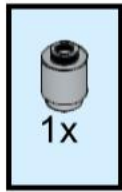

339

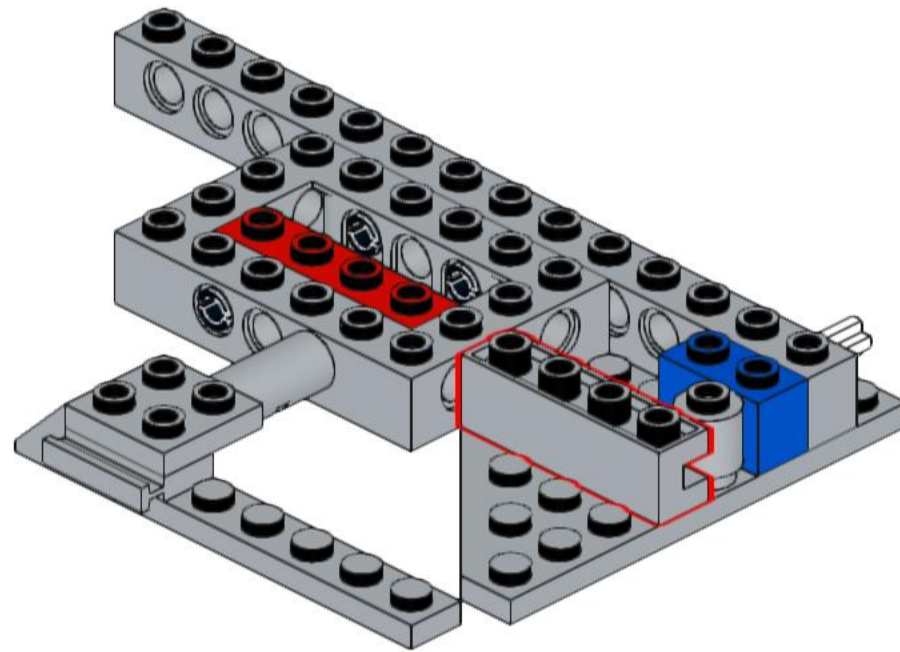
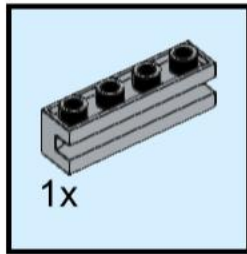

340

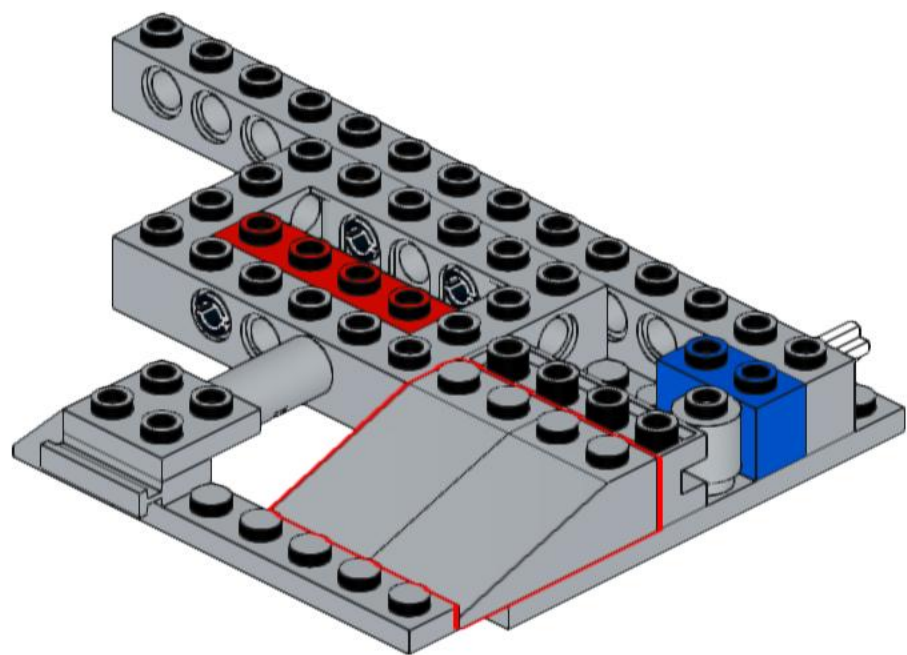
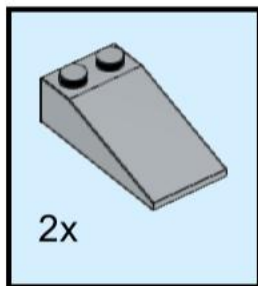

341

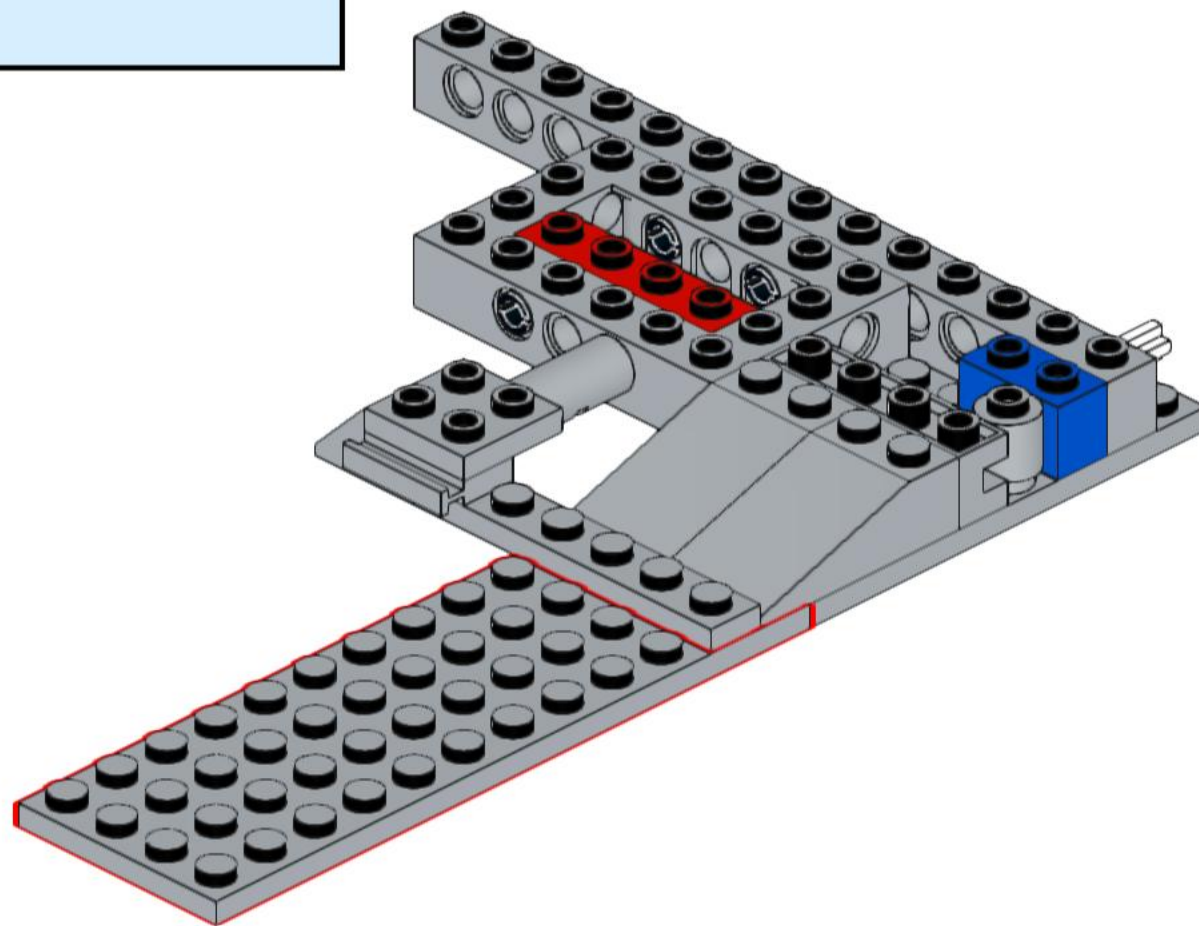
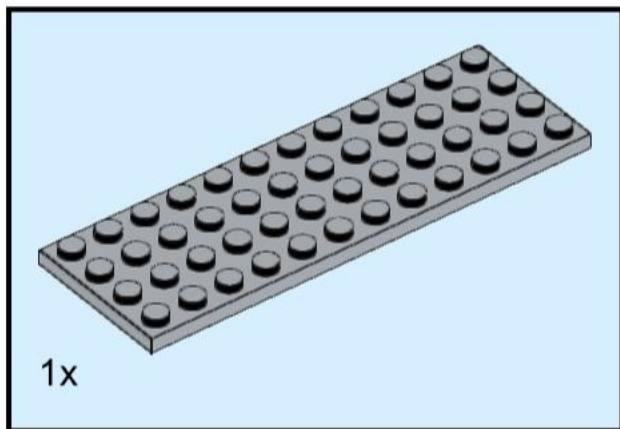

342

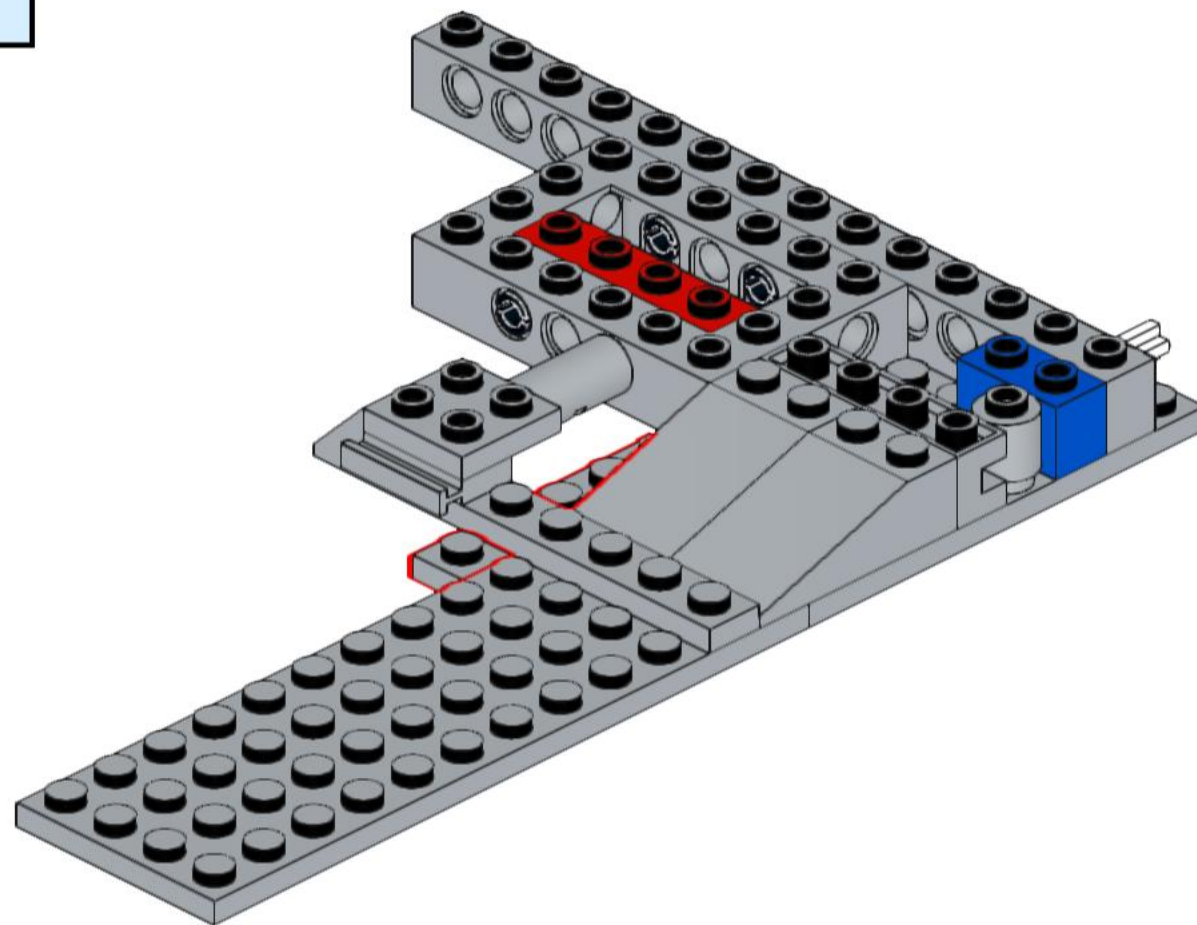
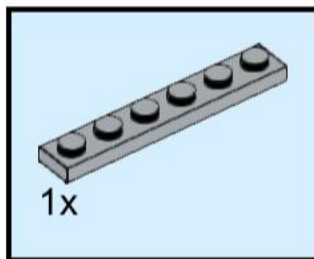

343

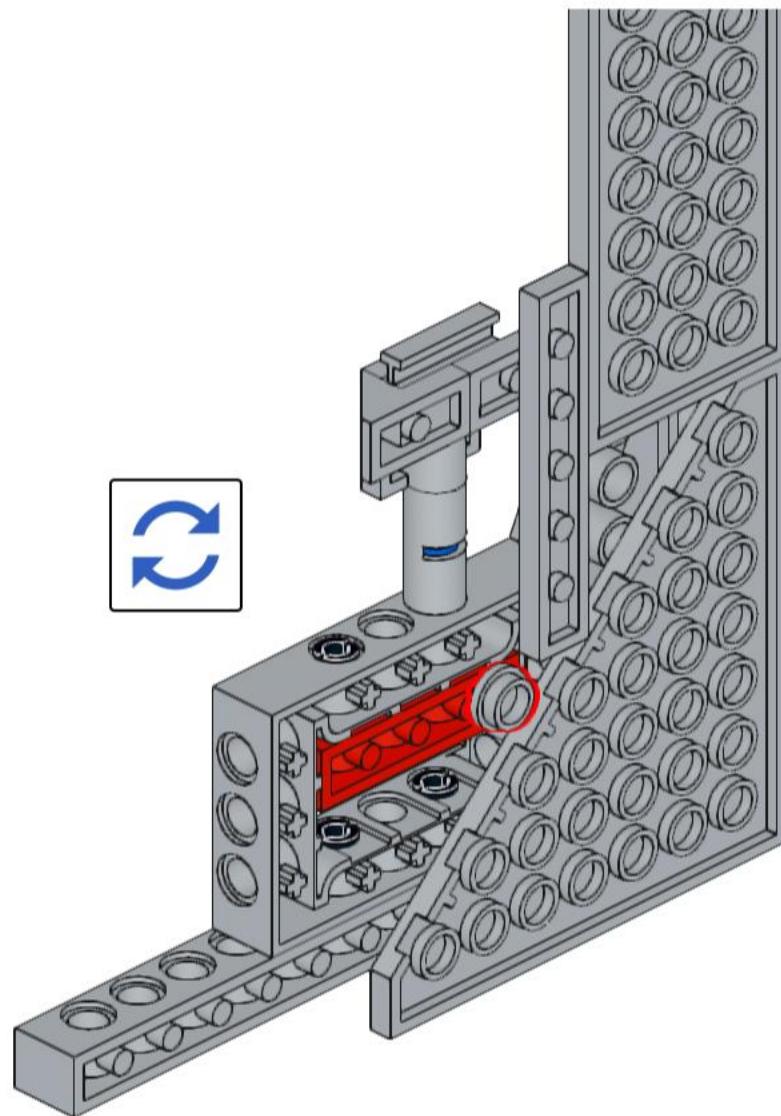

344

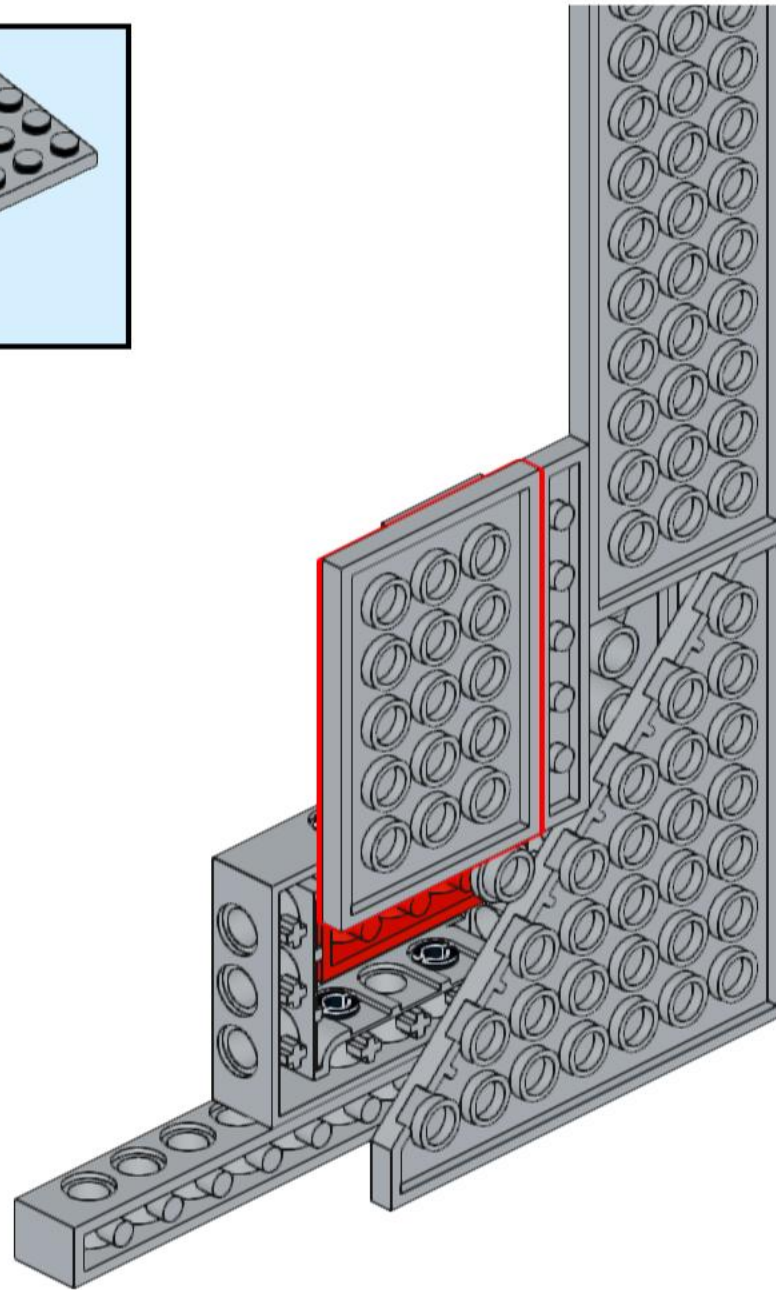
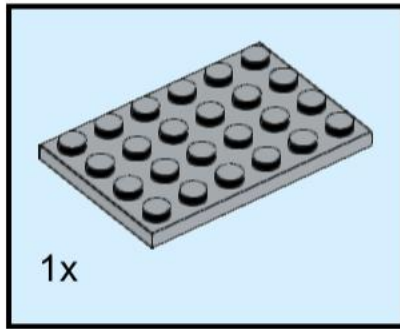

345

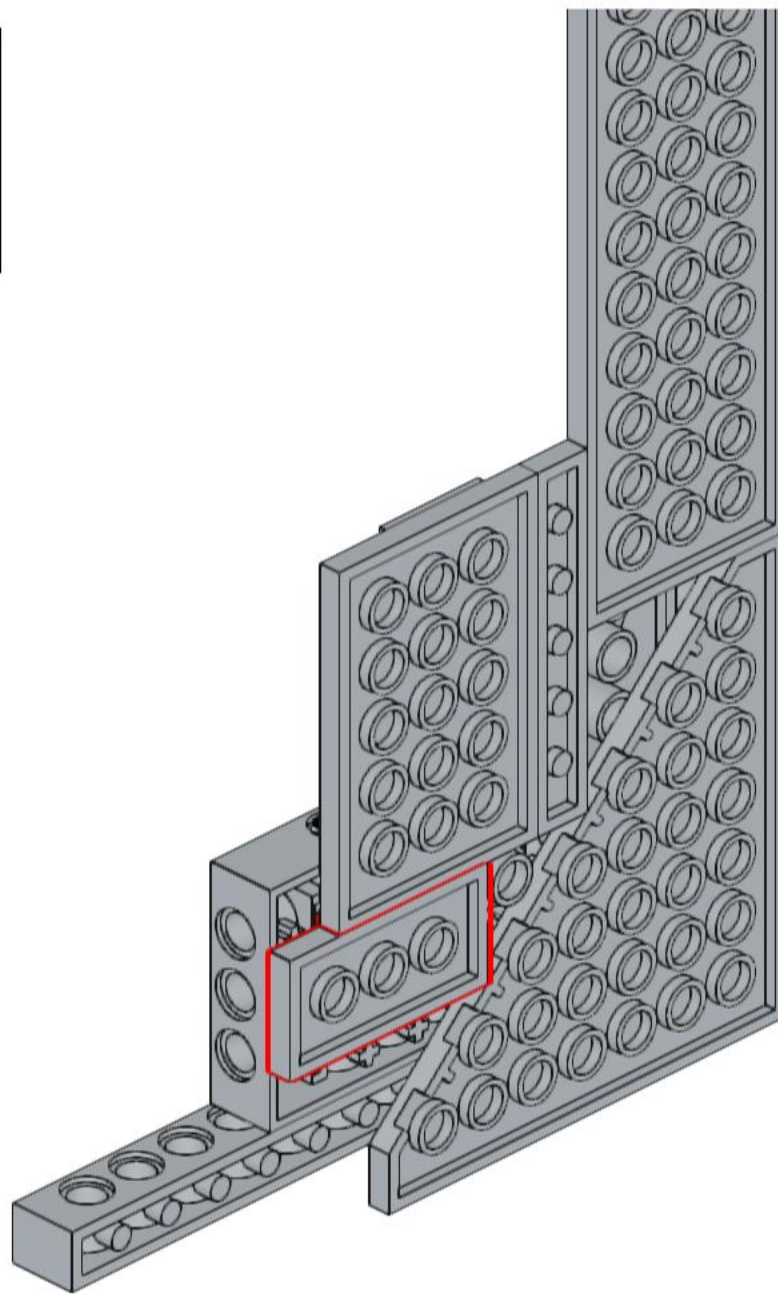
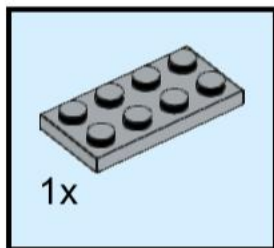

346

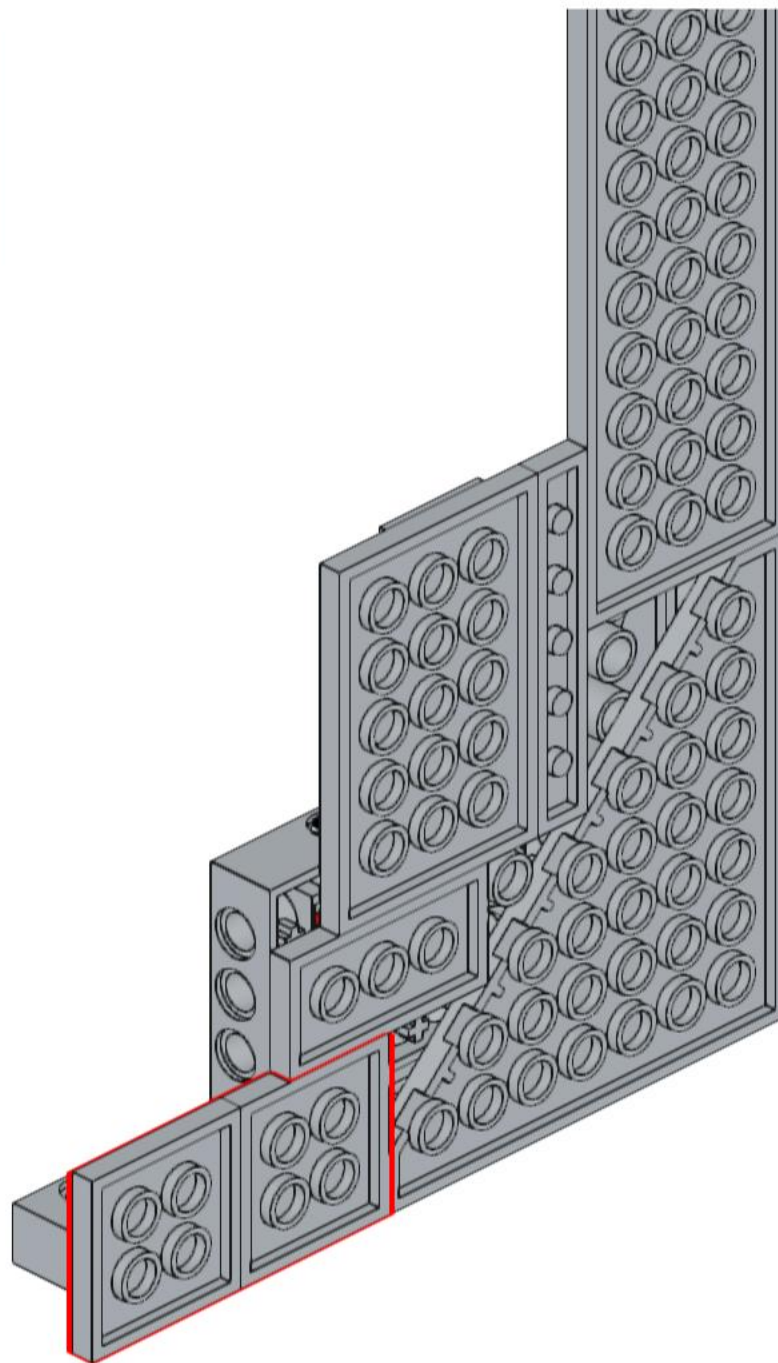
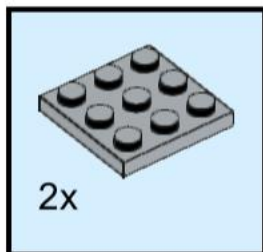

347

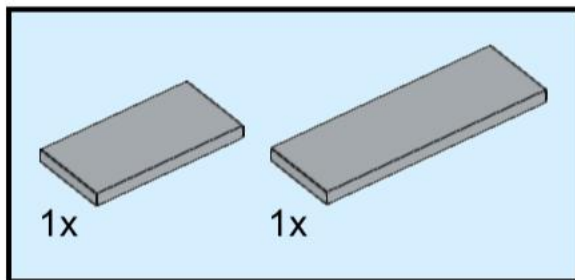

These tiles are trapped by the rail piece above them. Slightly raise the rail piece or remove the underlying plates to make placing the tiles easier.

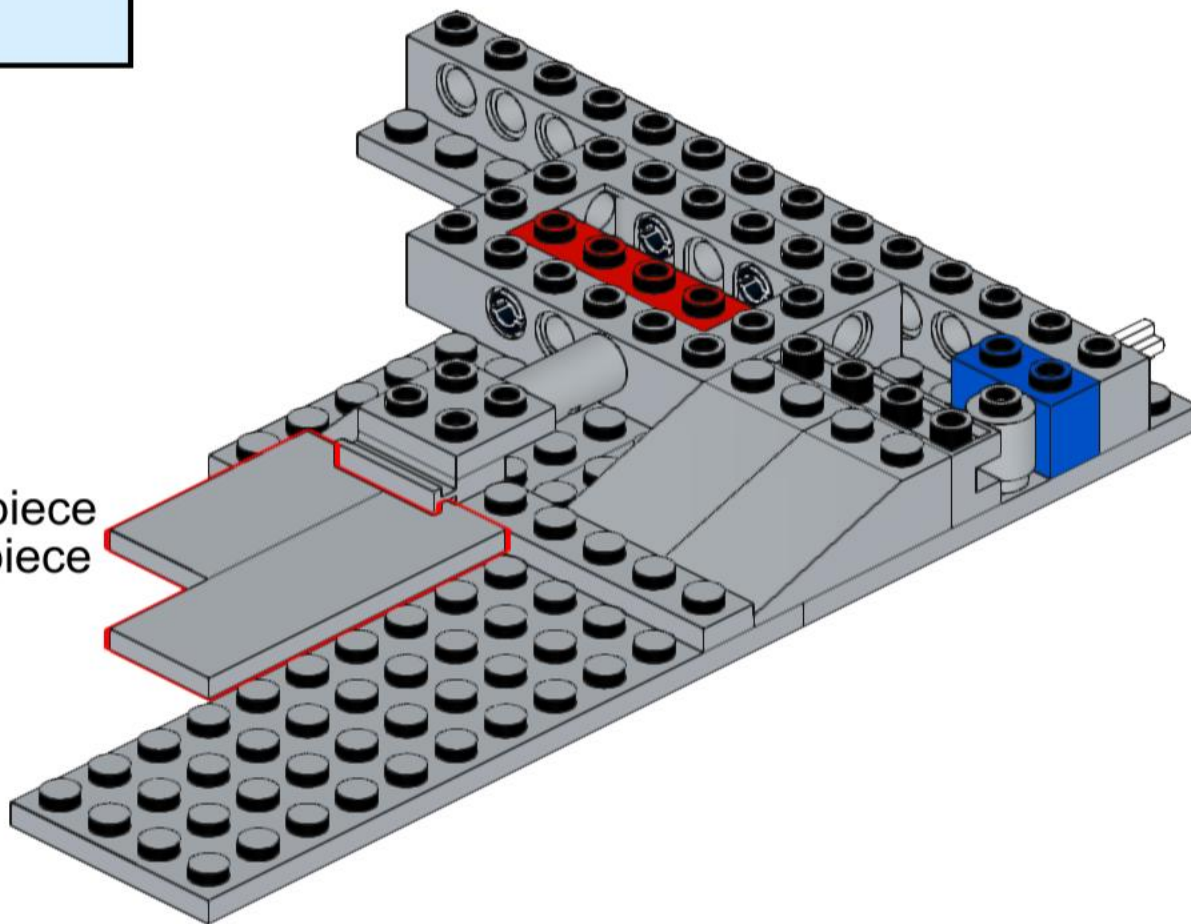

348

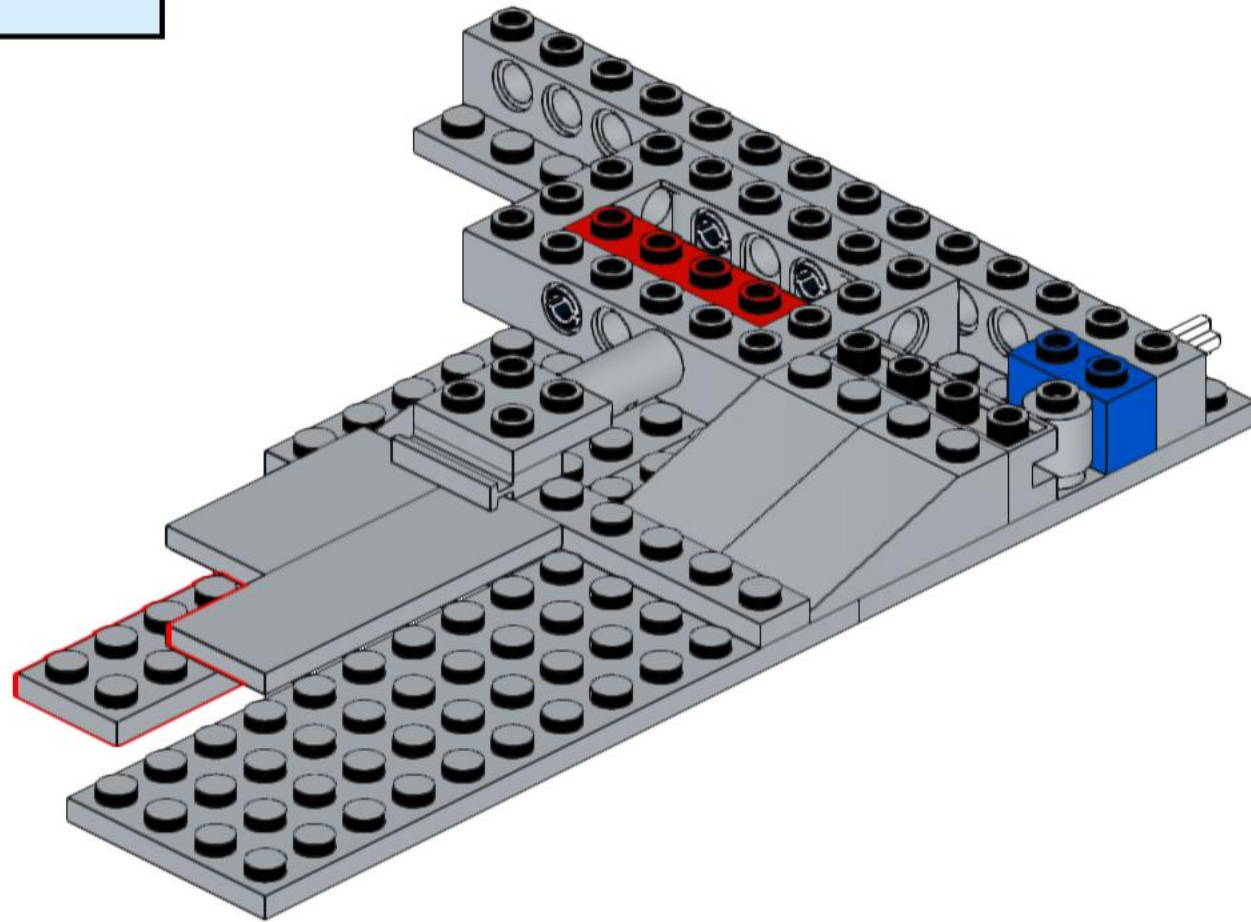
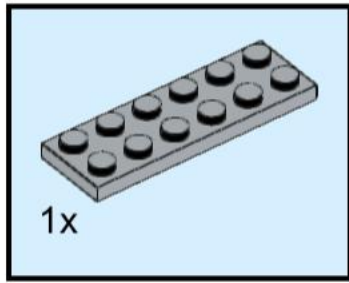

349

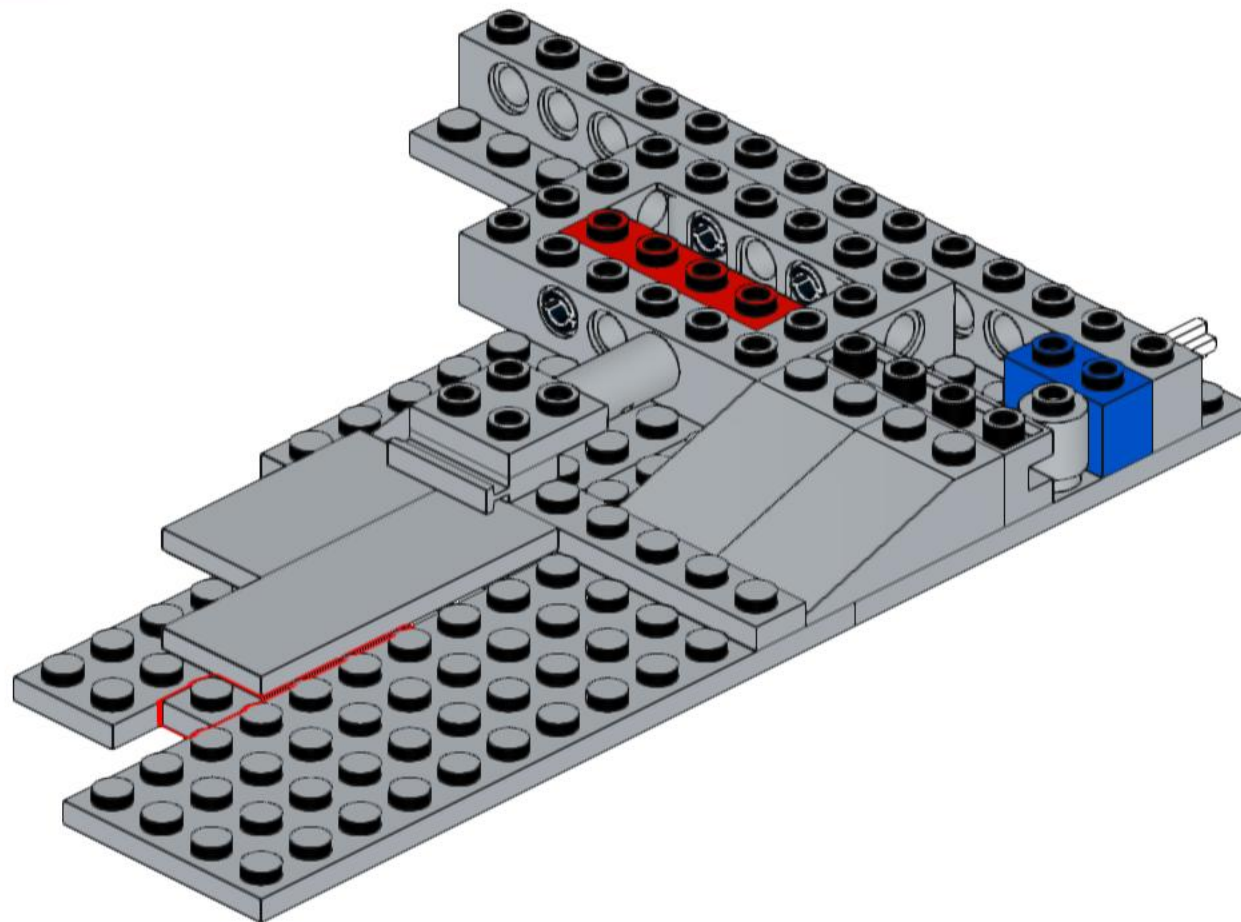
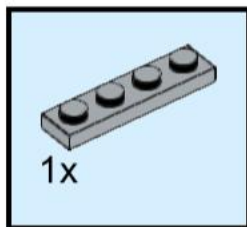

350

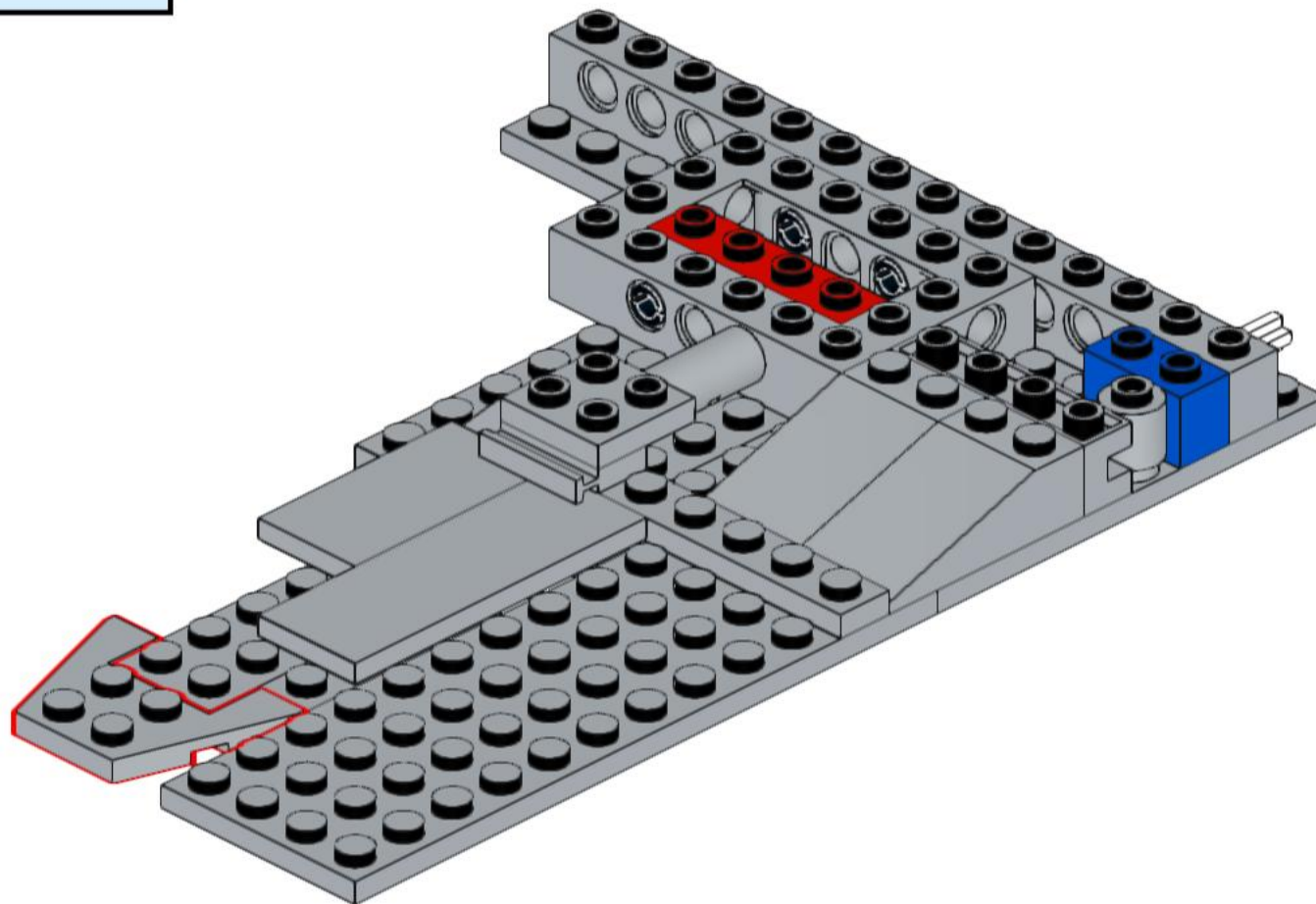
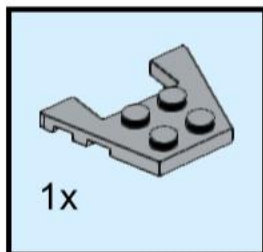

351

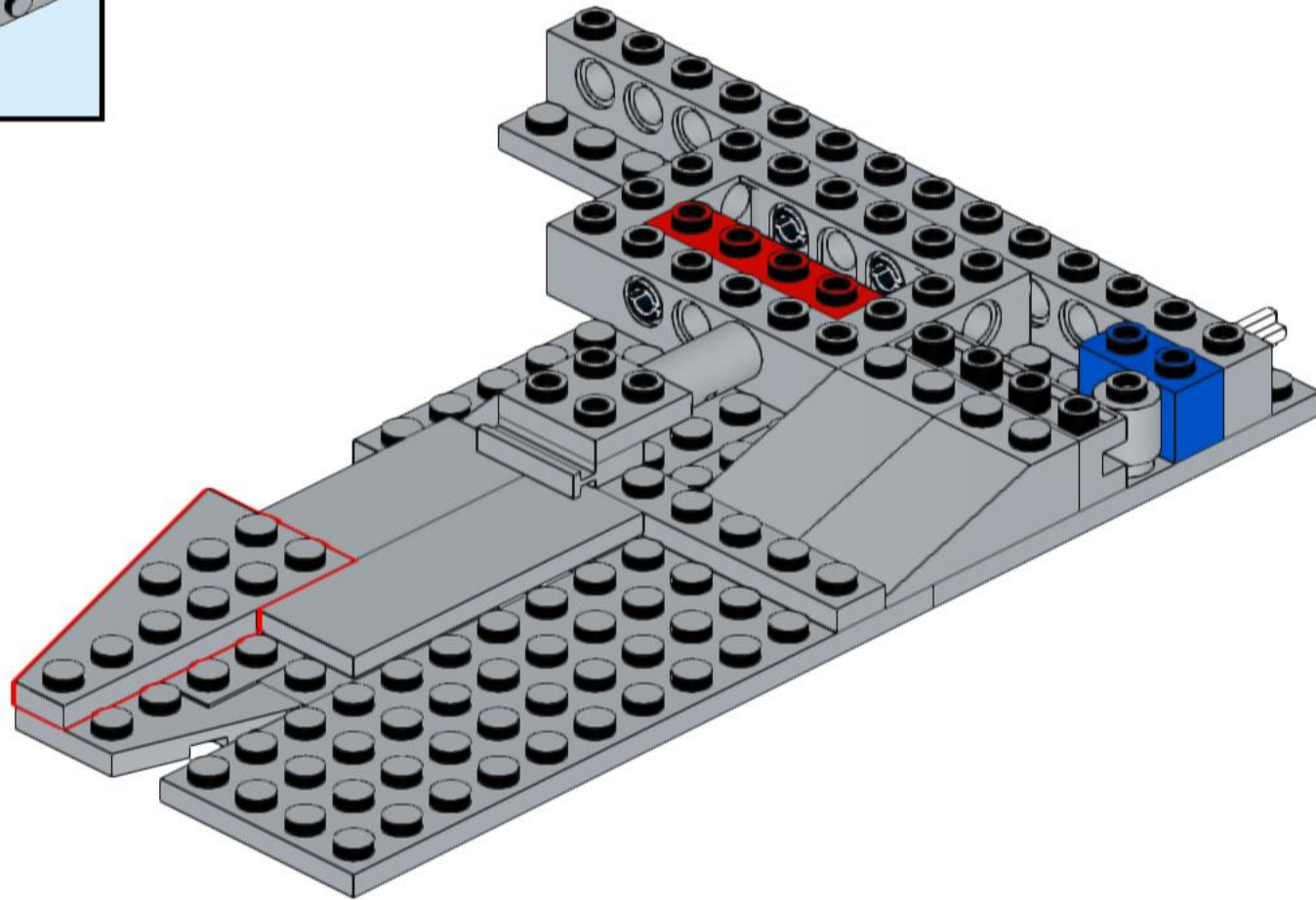
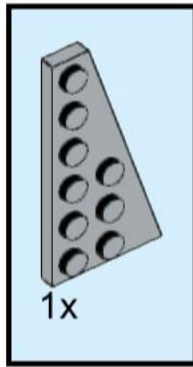

352

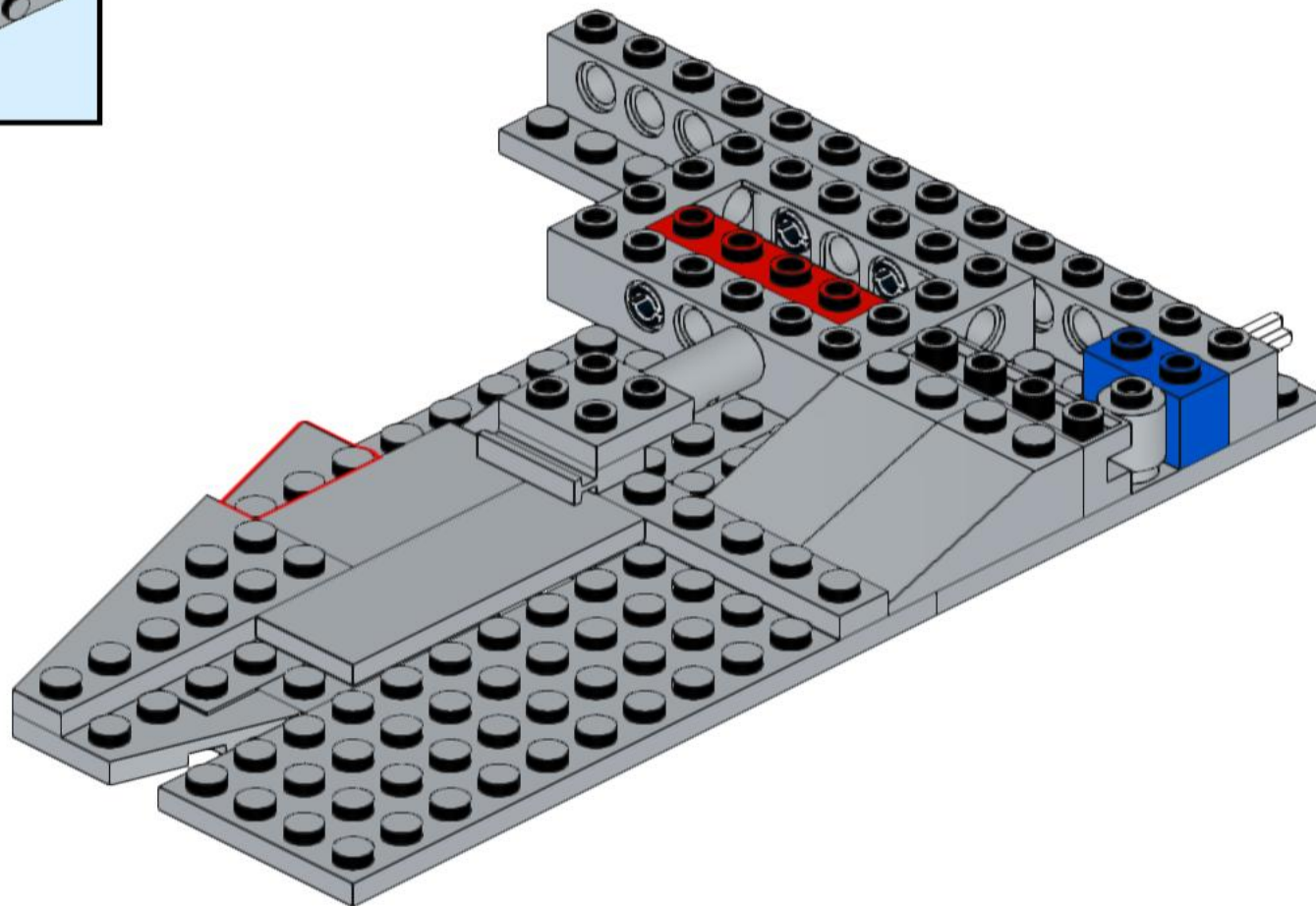
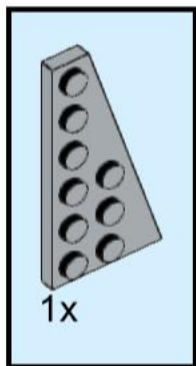

353

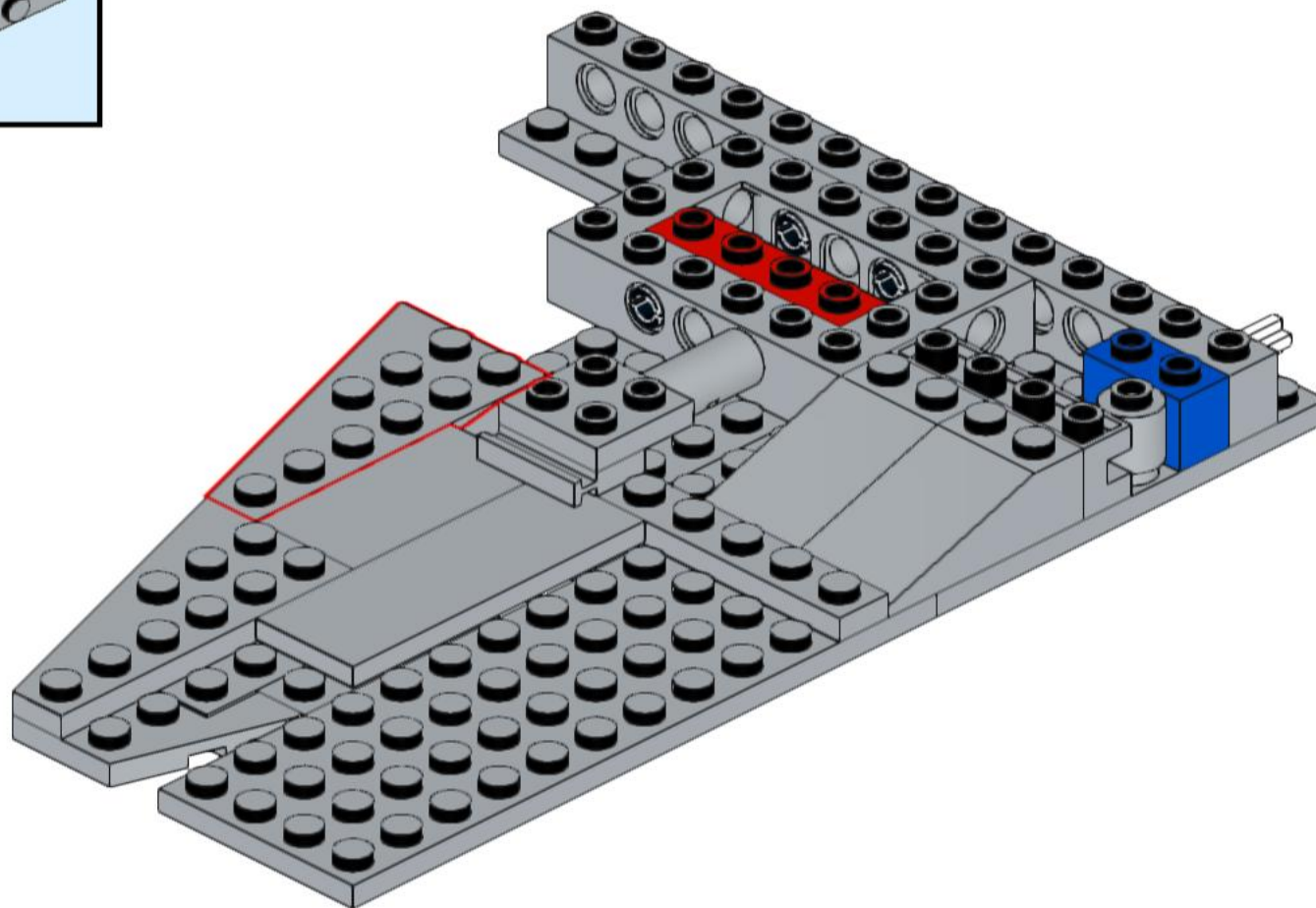
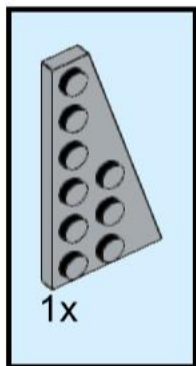

354

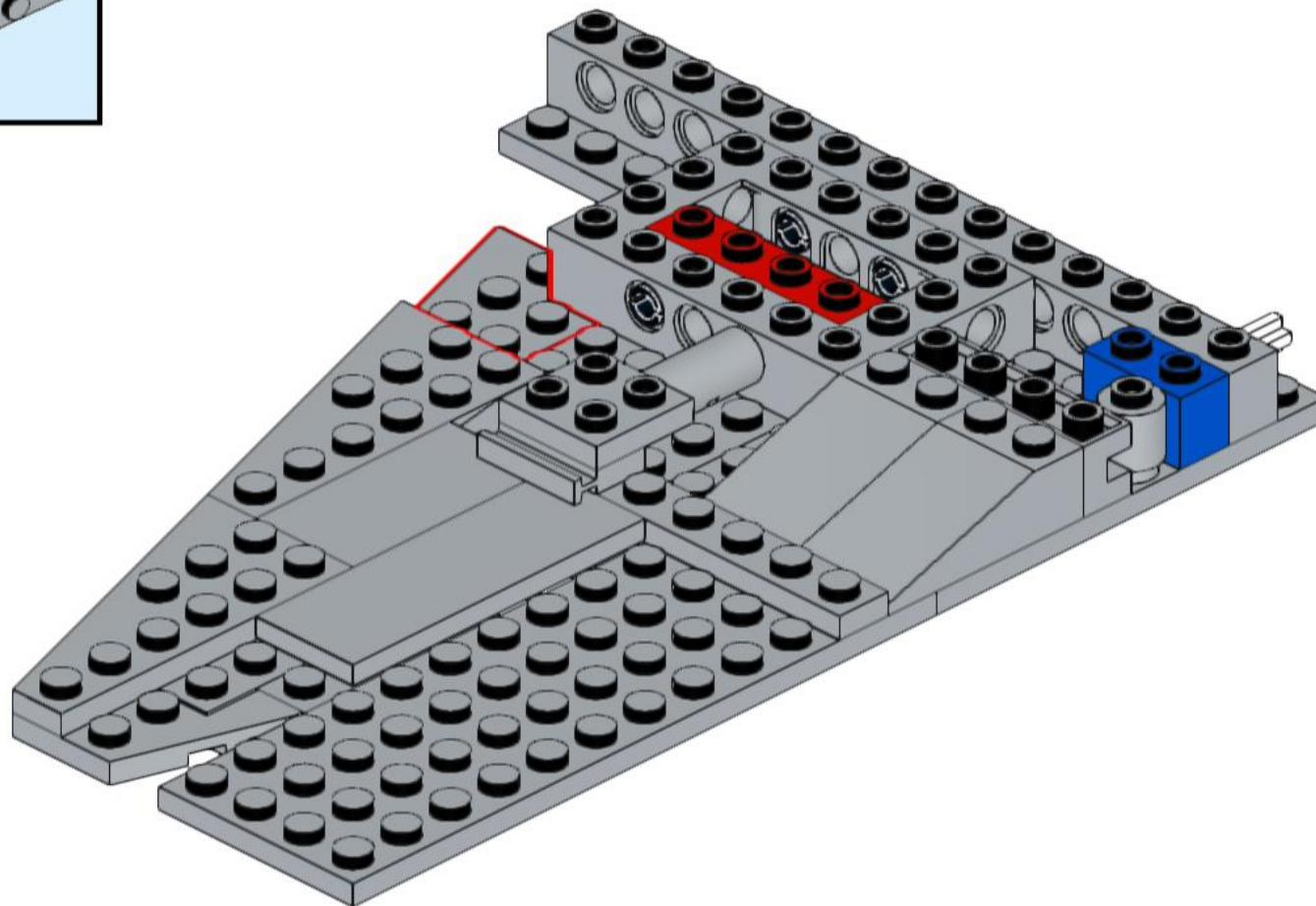
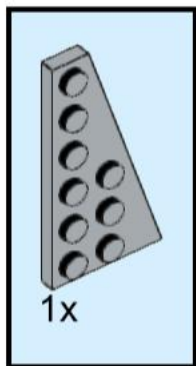

355

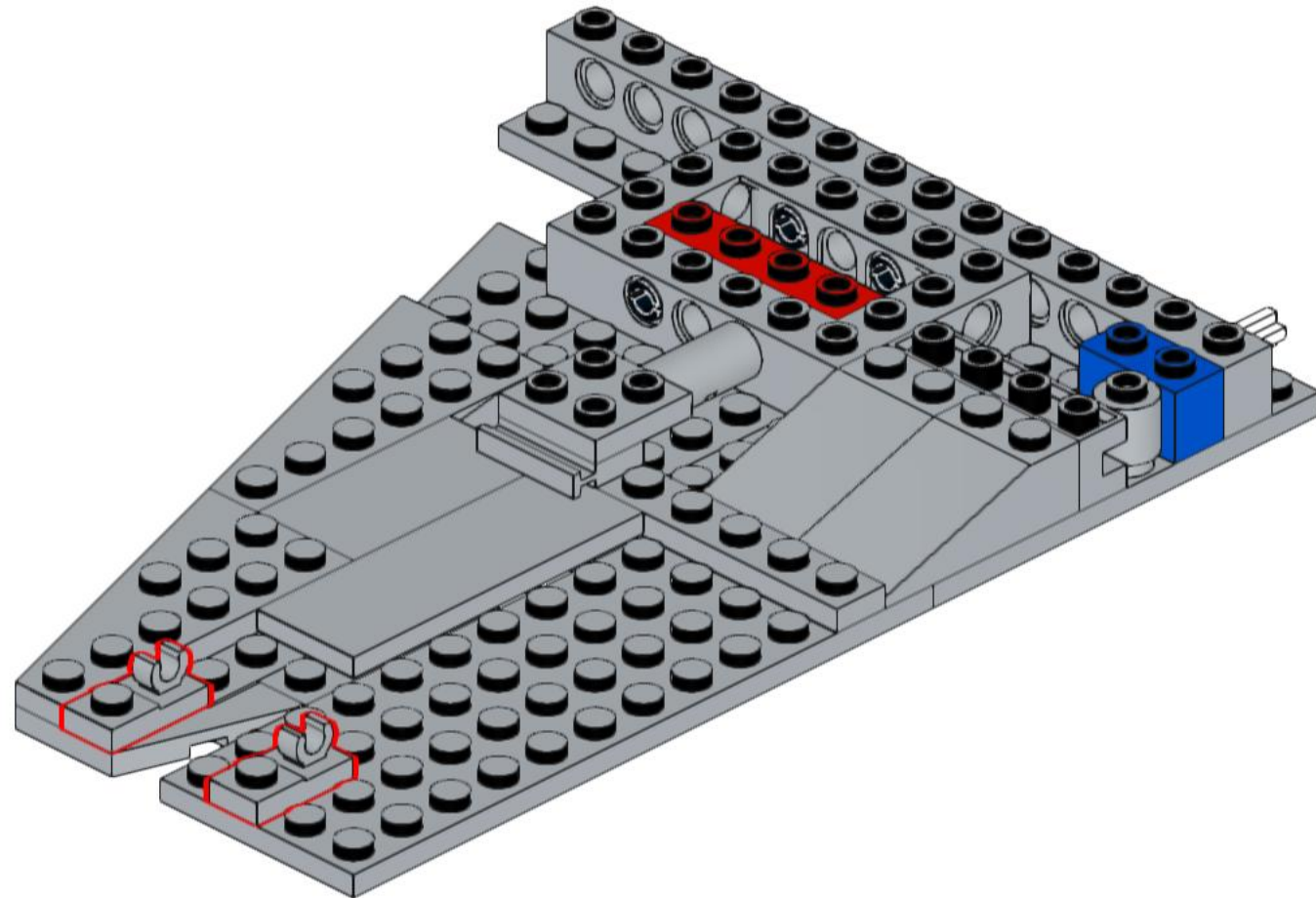
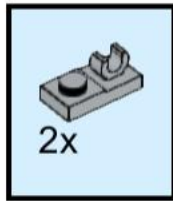

356

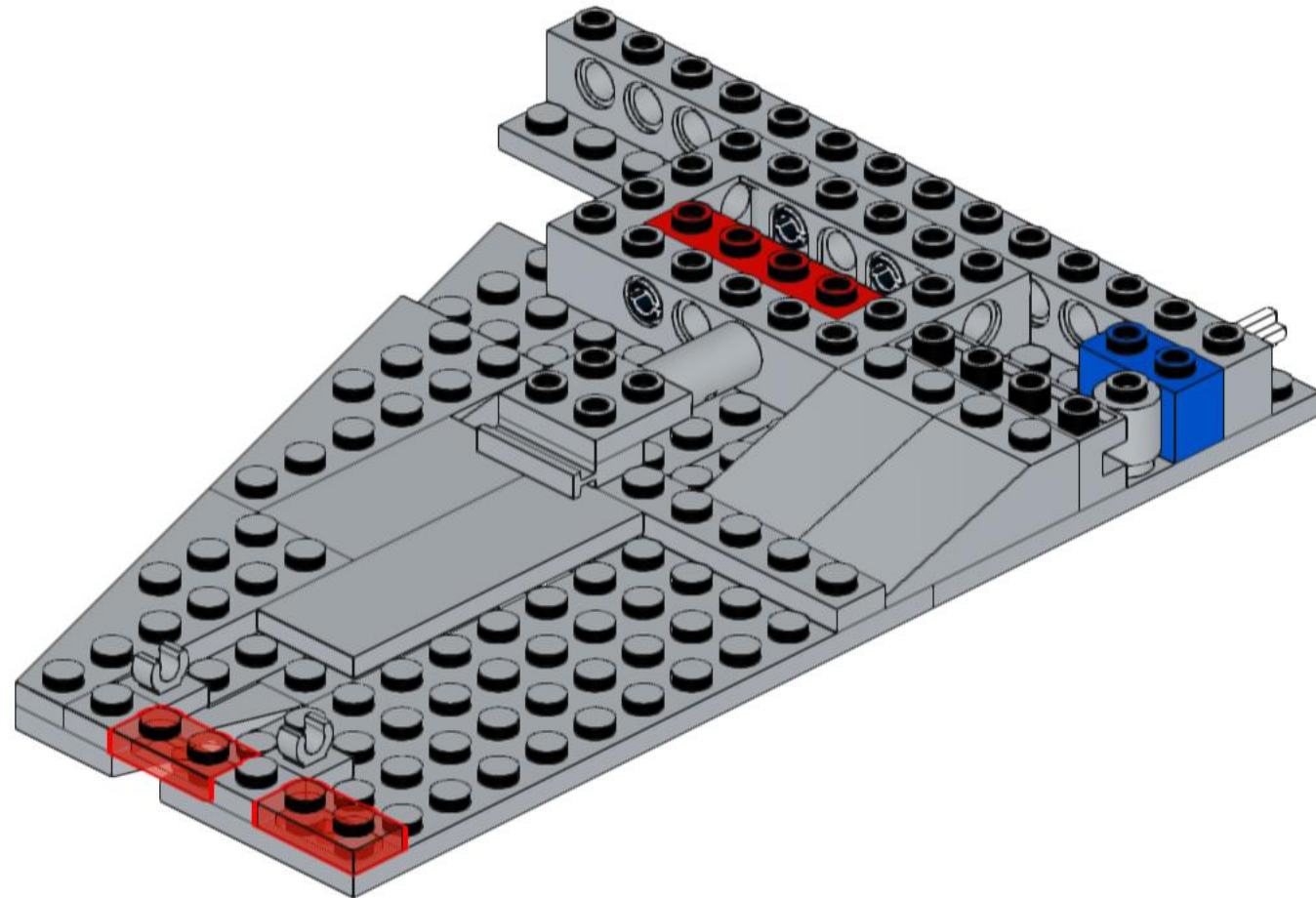
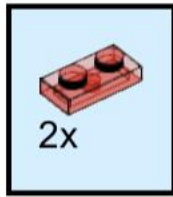

357

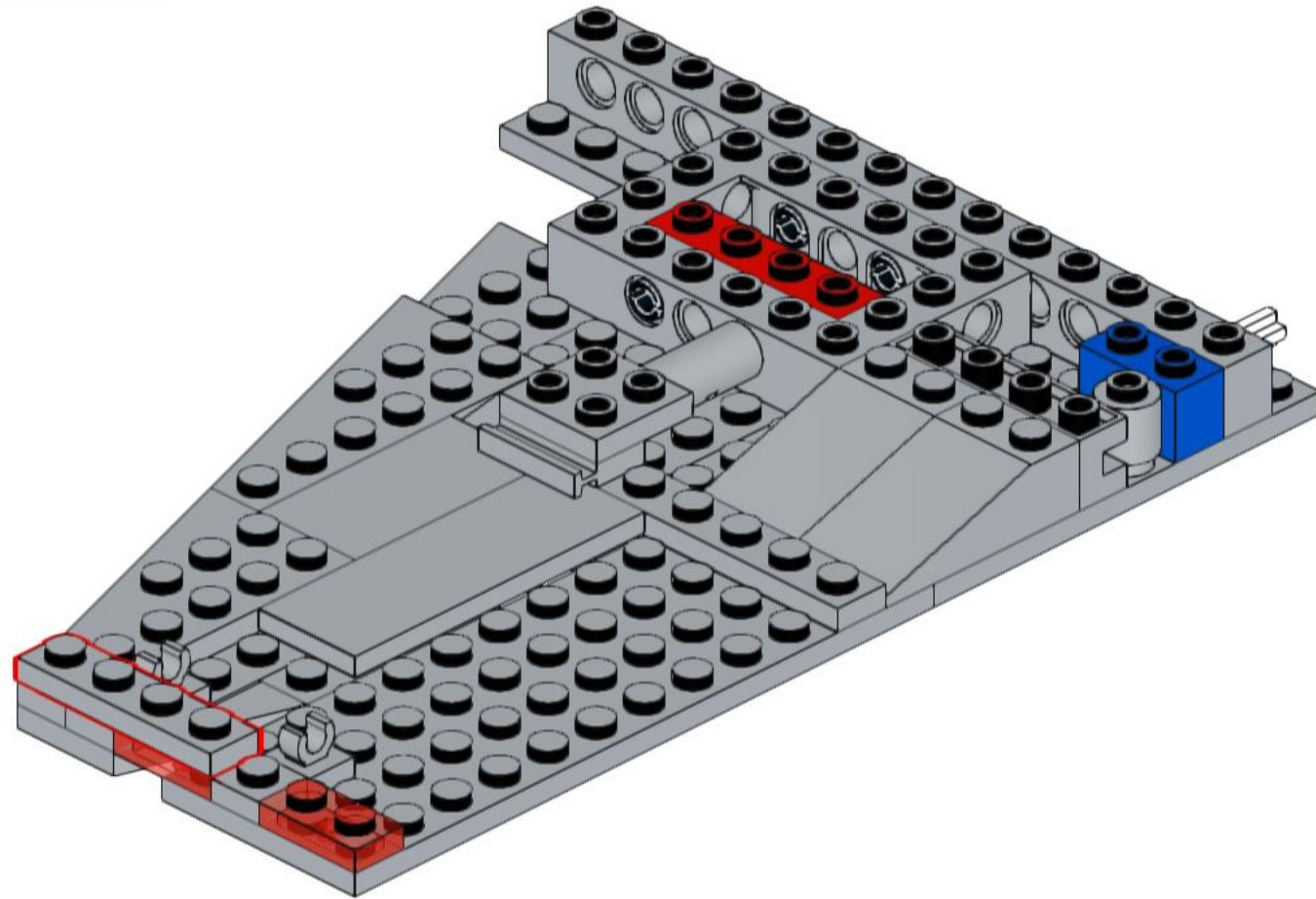
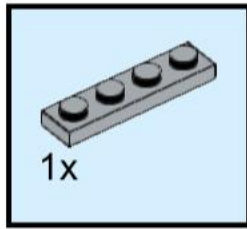

358

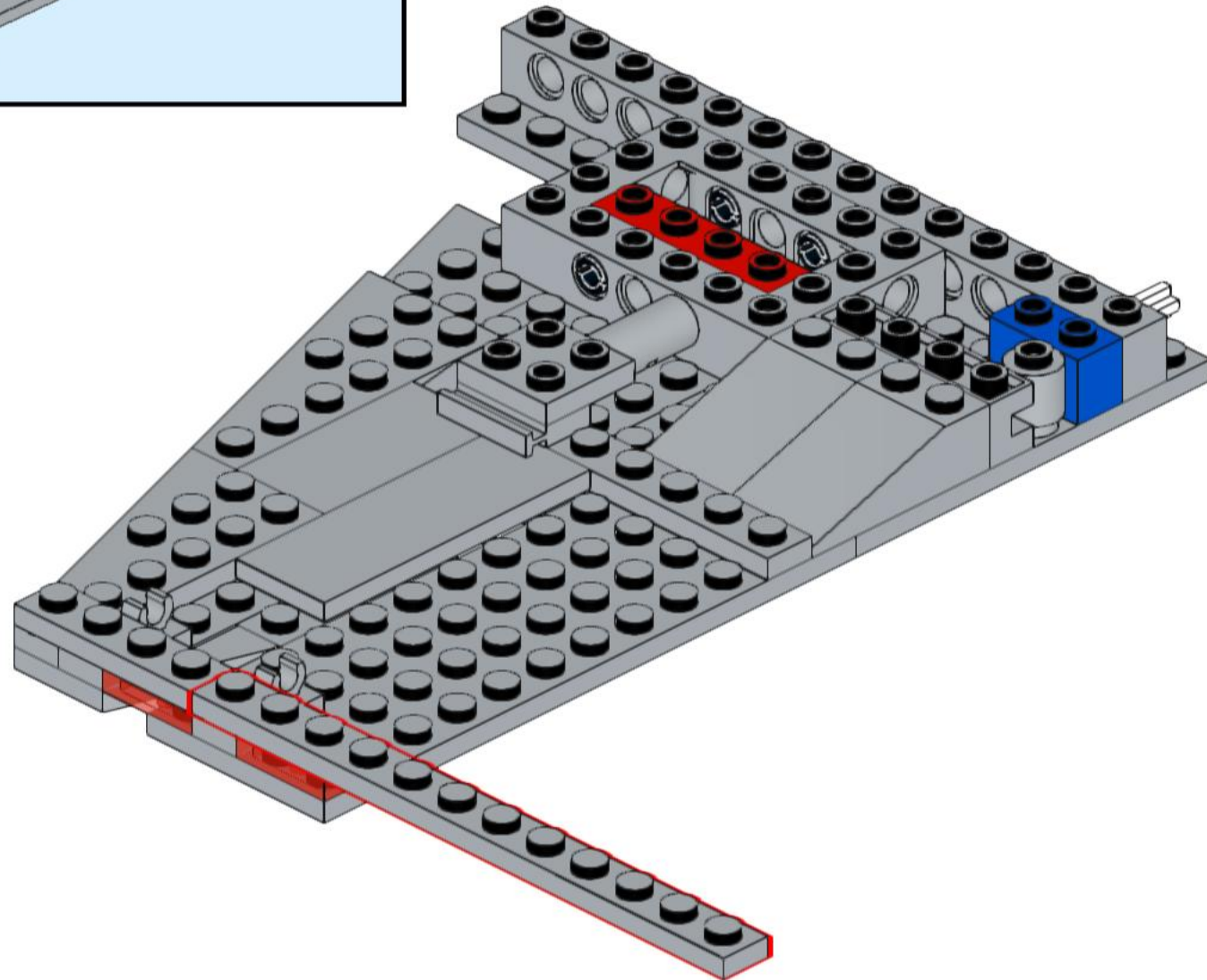
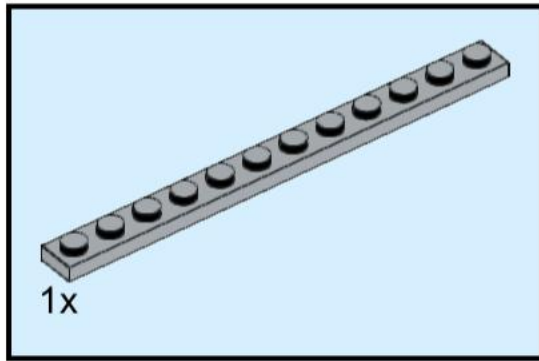

359

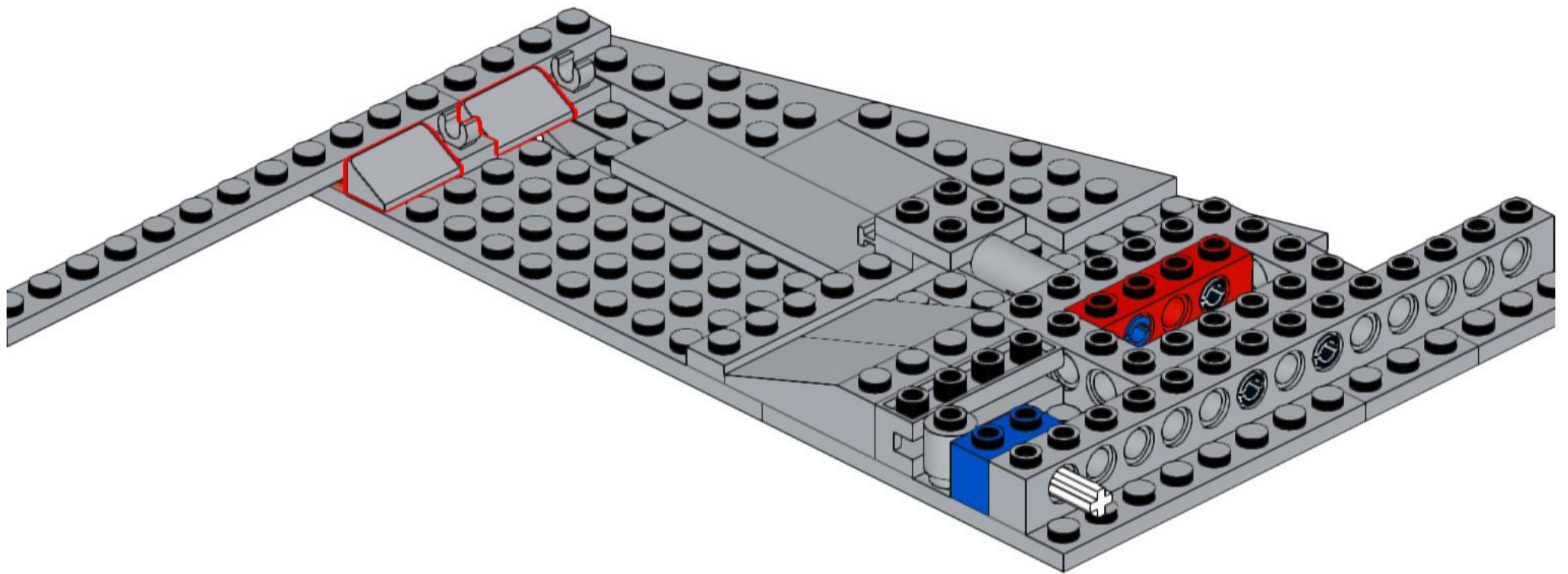
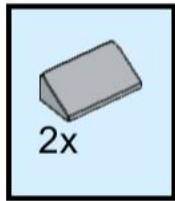

360

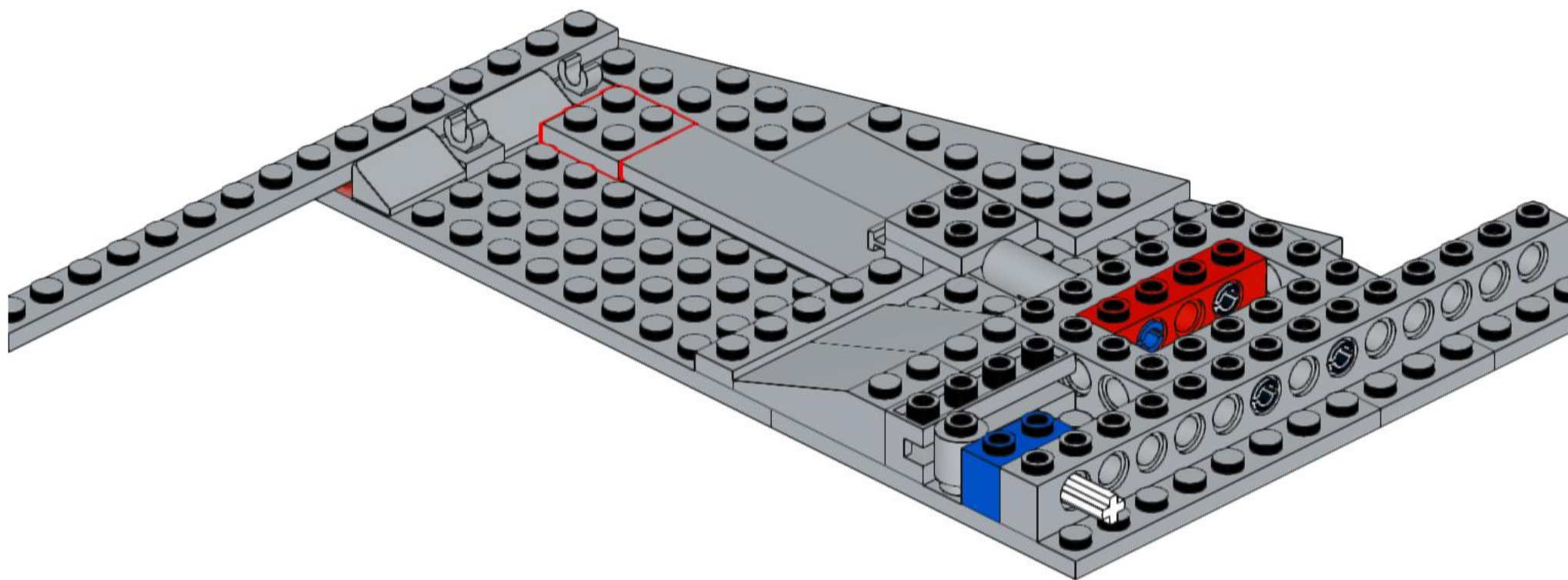
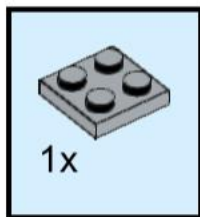

361

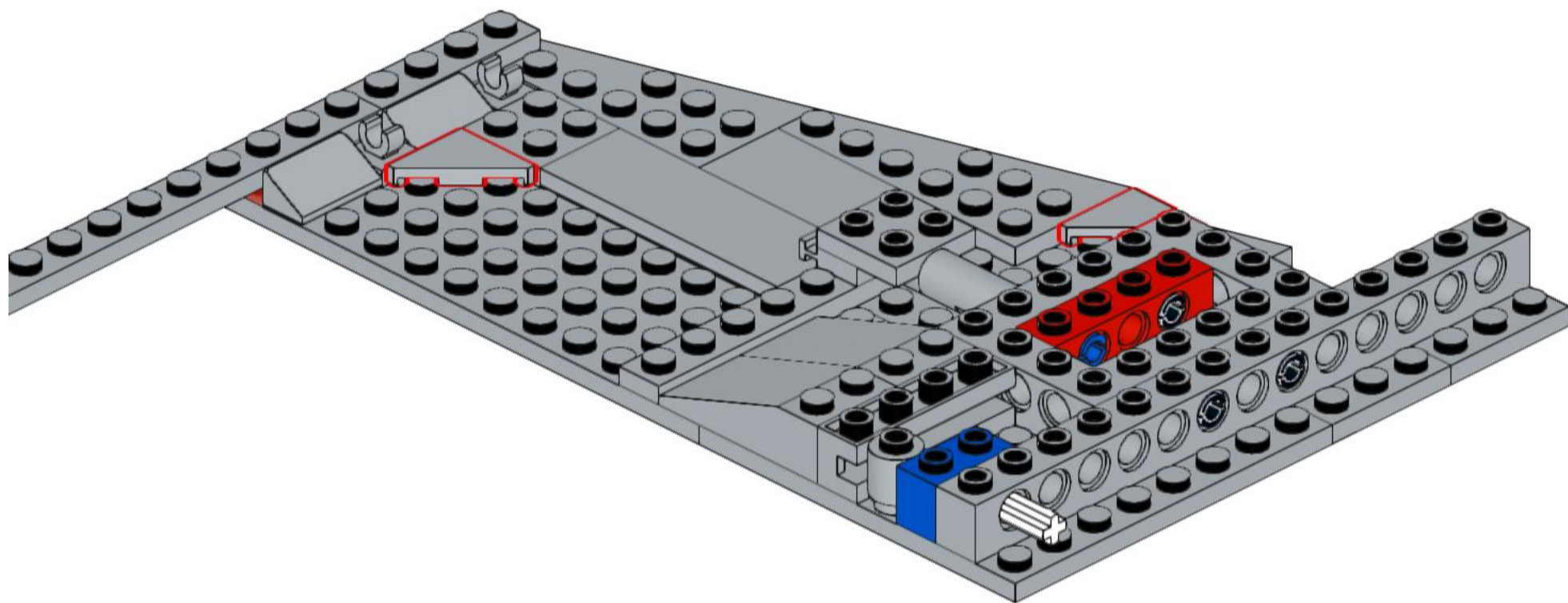
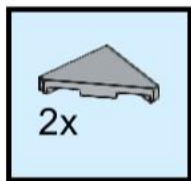

362

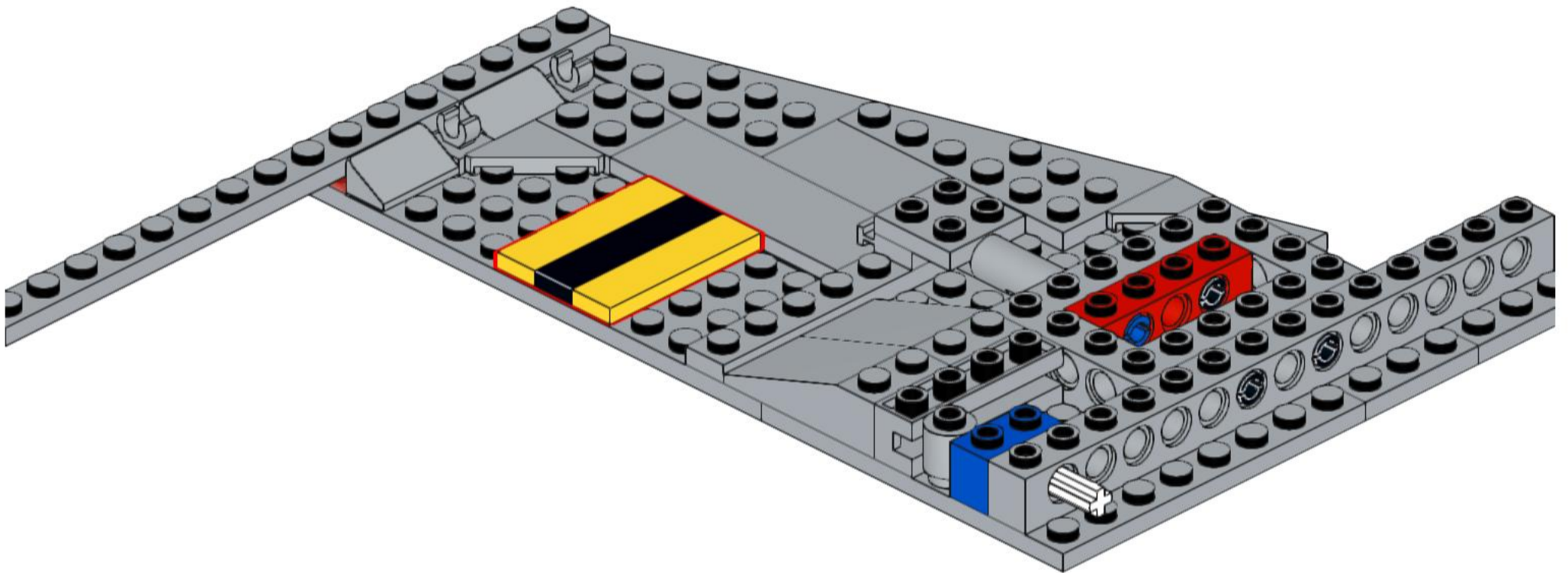
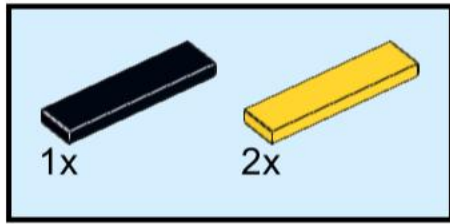

363

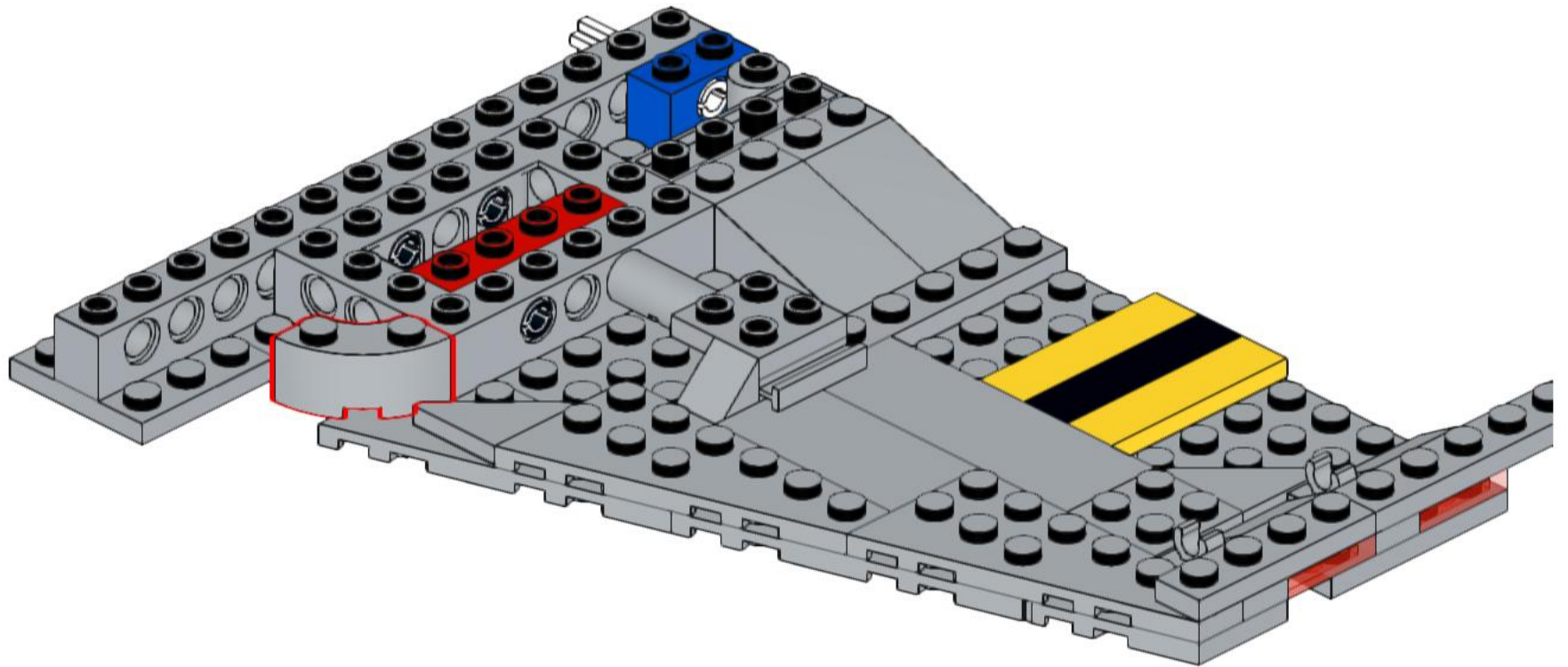
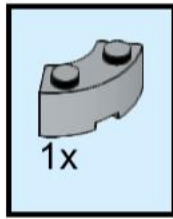

364

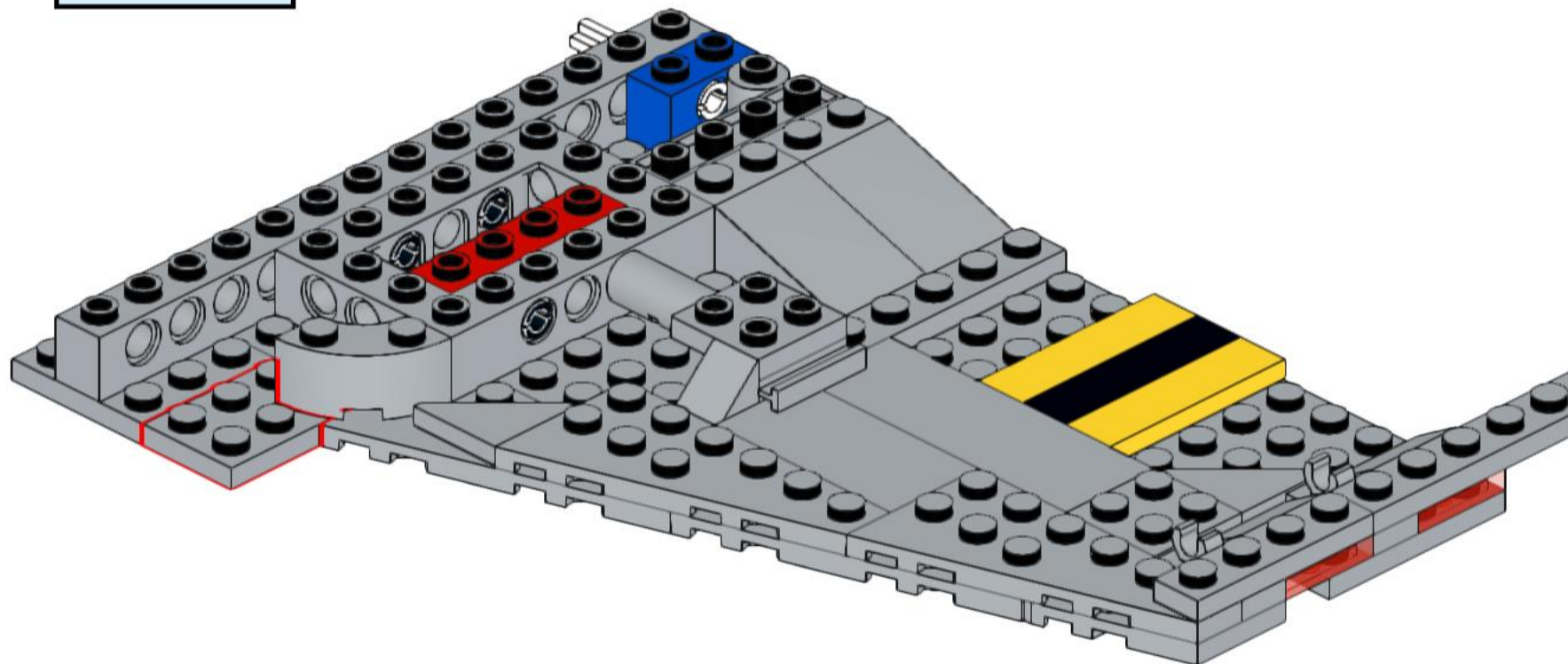
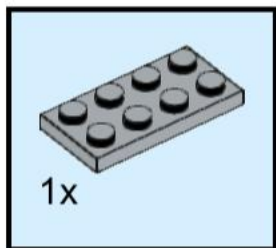

365

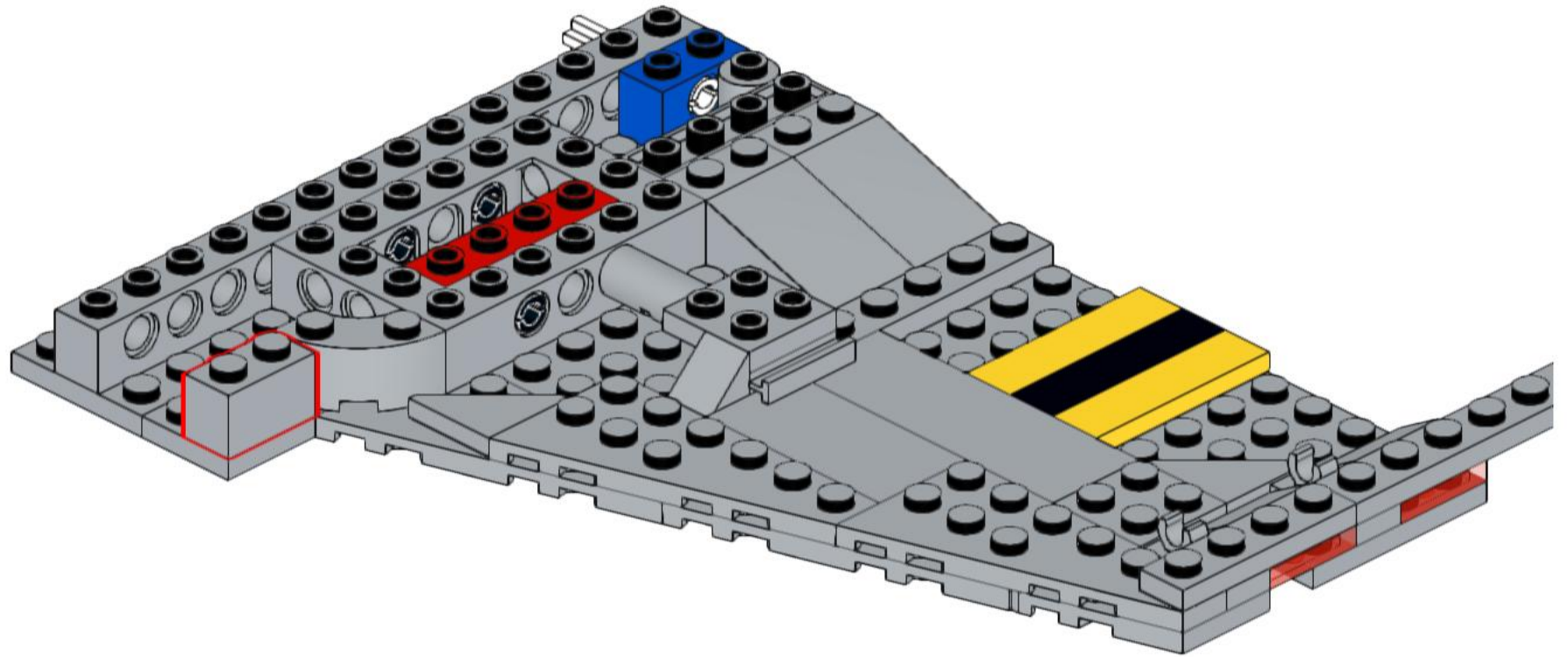
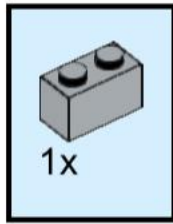

366

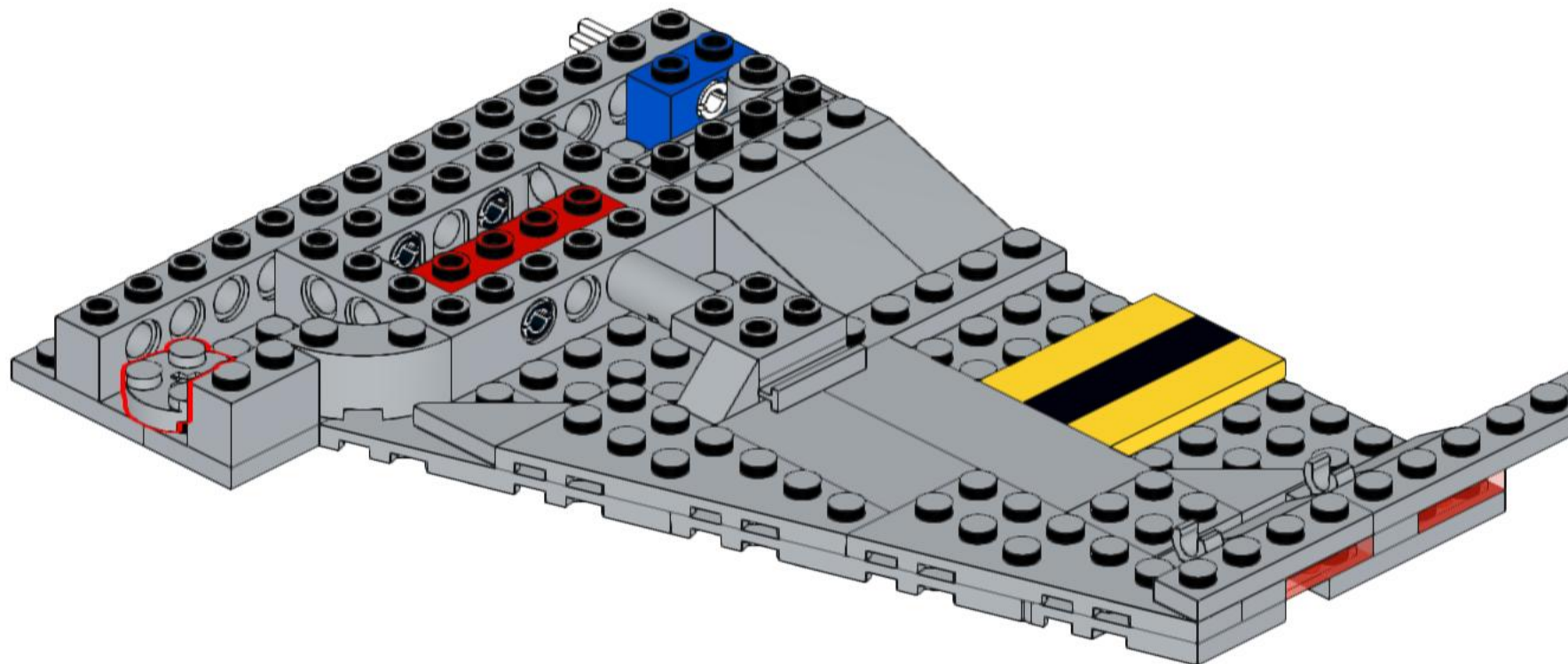
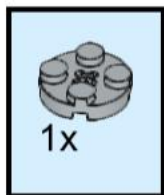

367

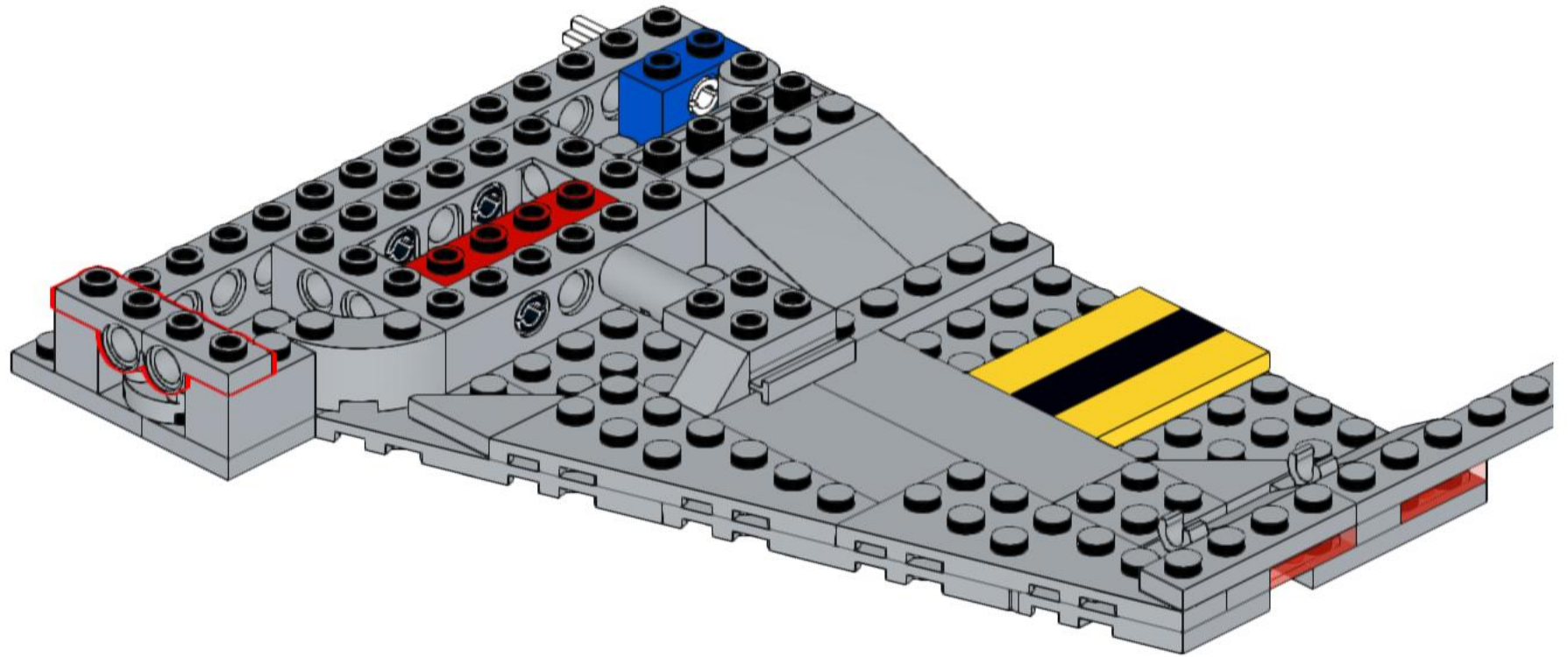
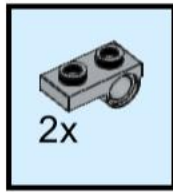

368

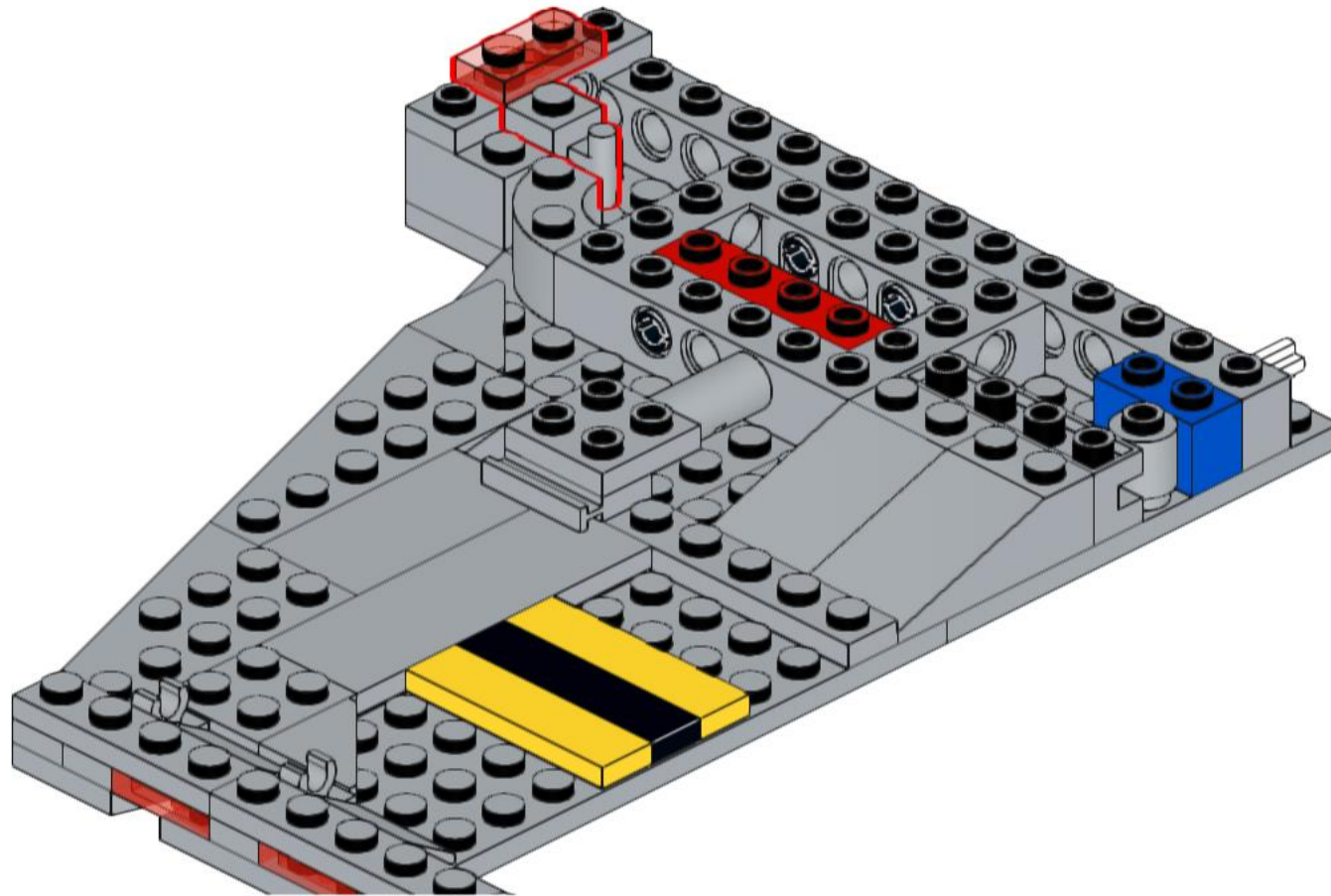
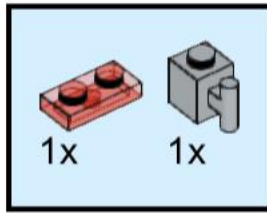

369

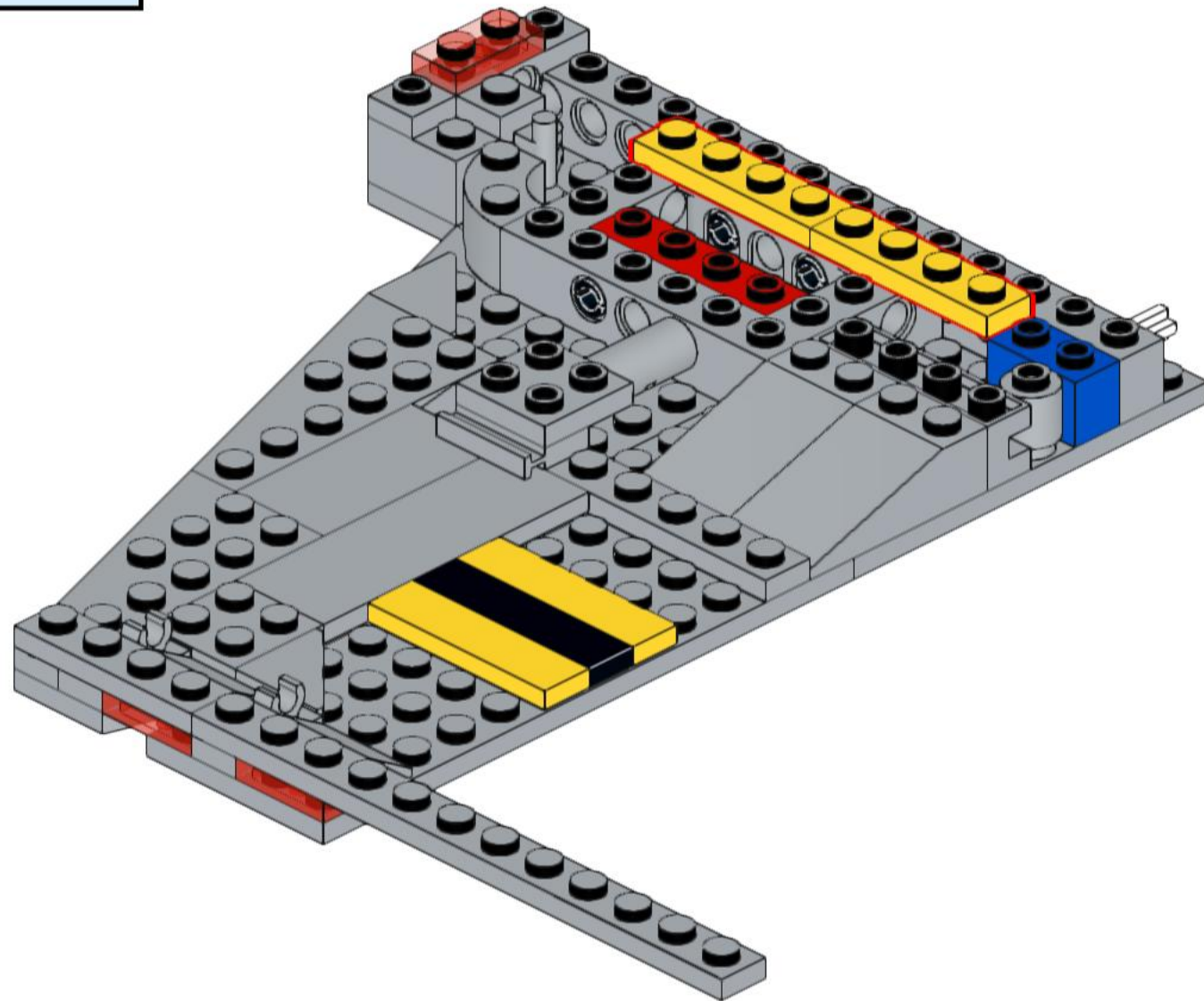
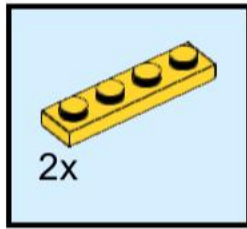

370

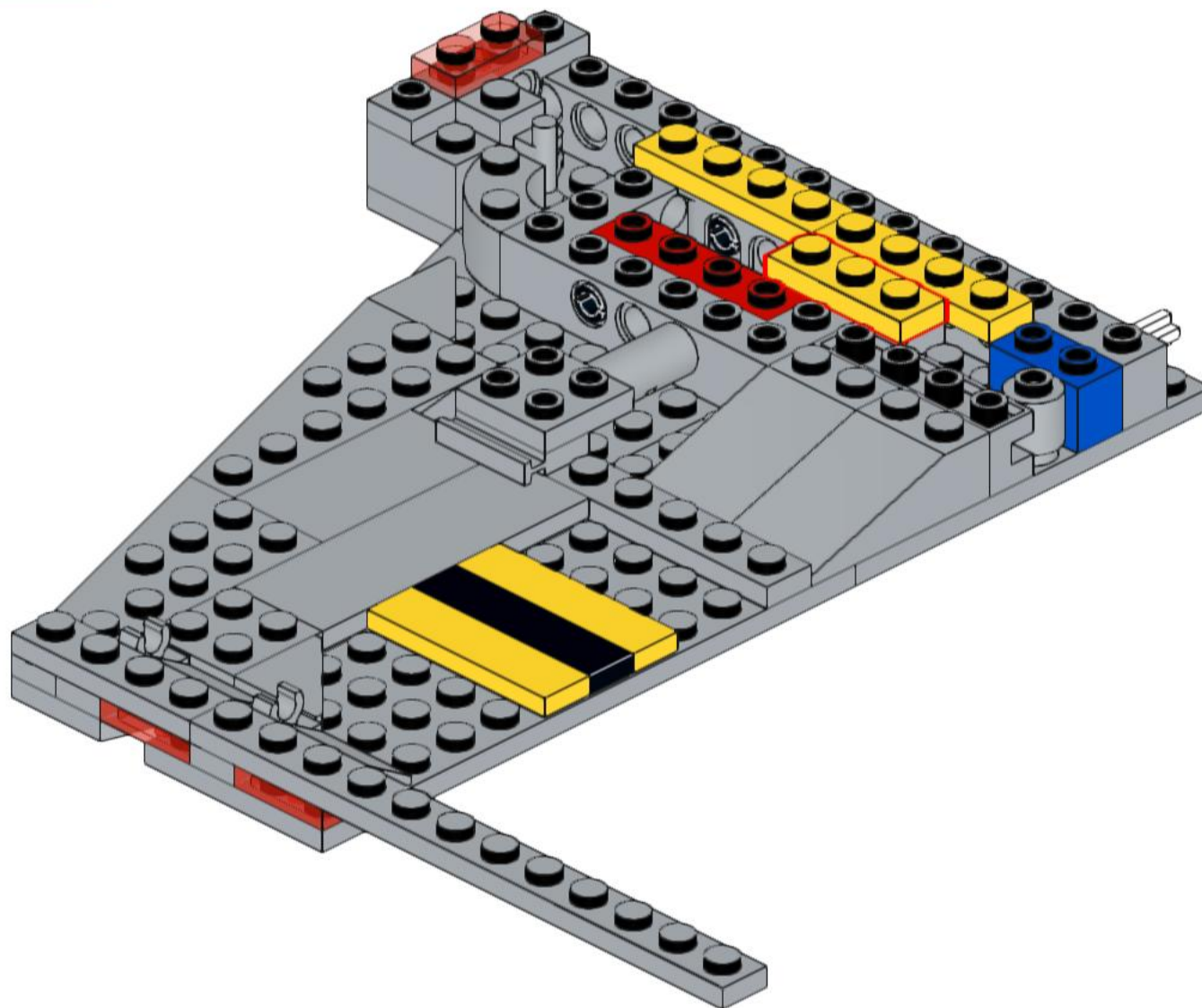
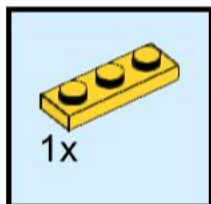

371

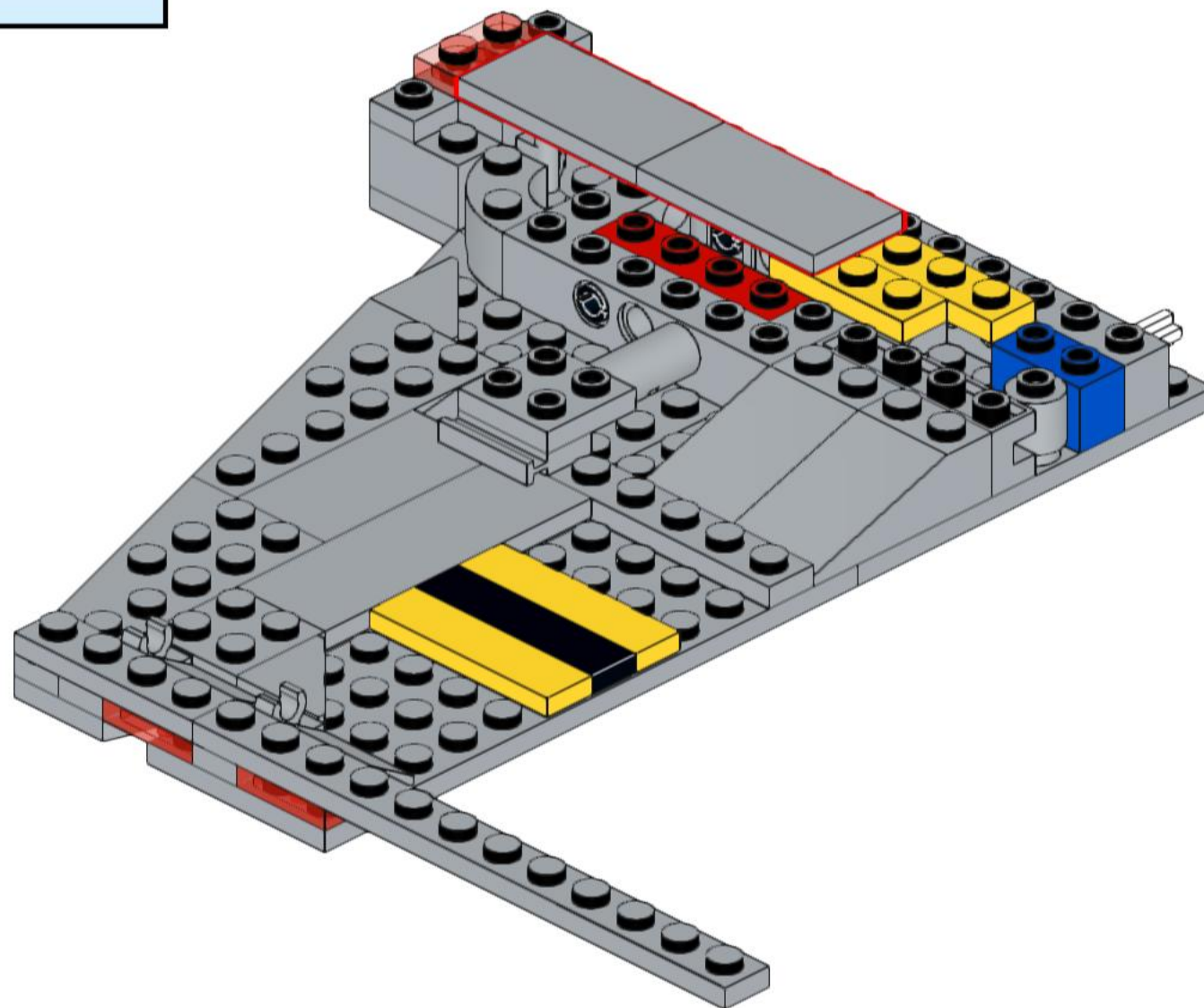
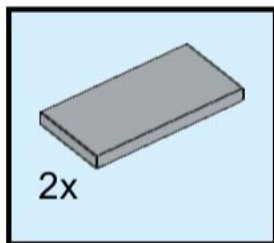

372

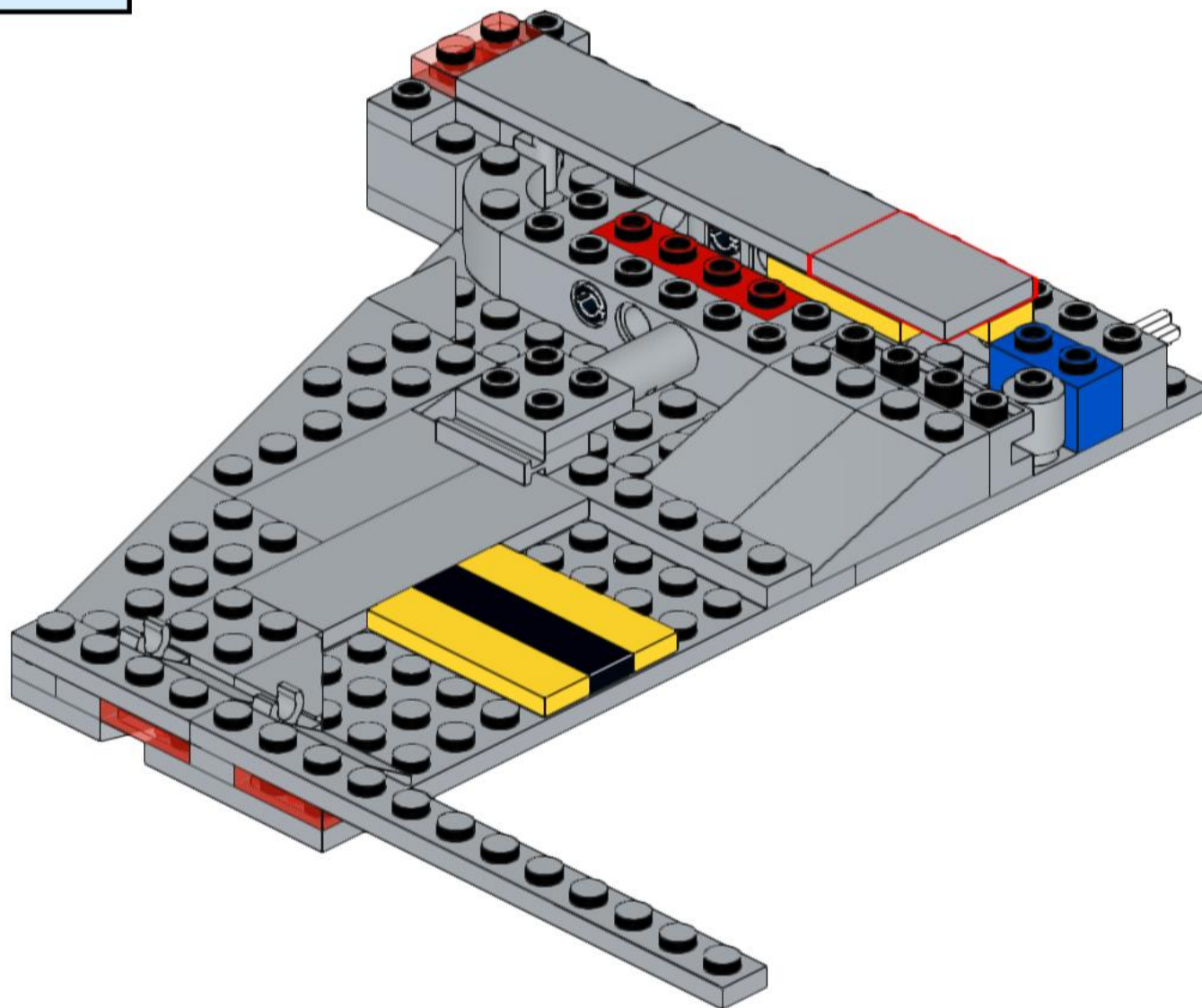
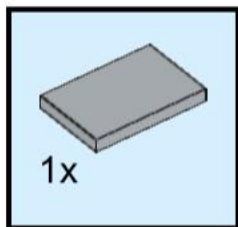

373

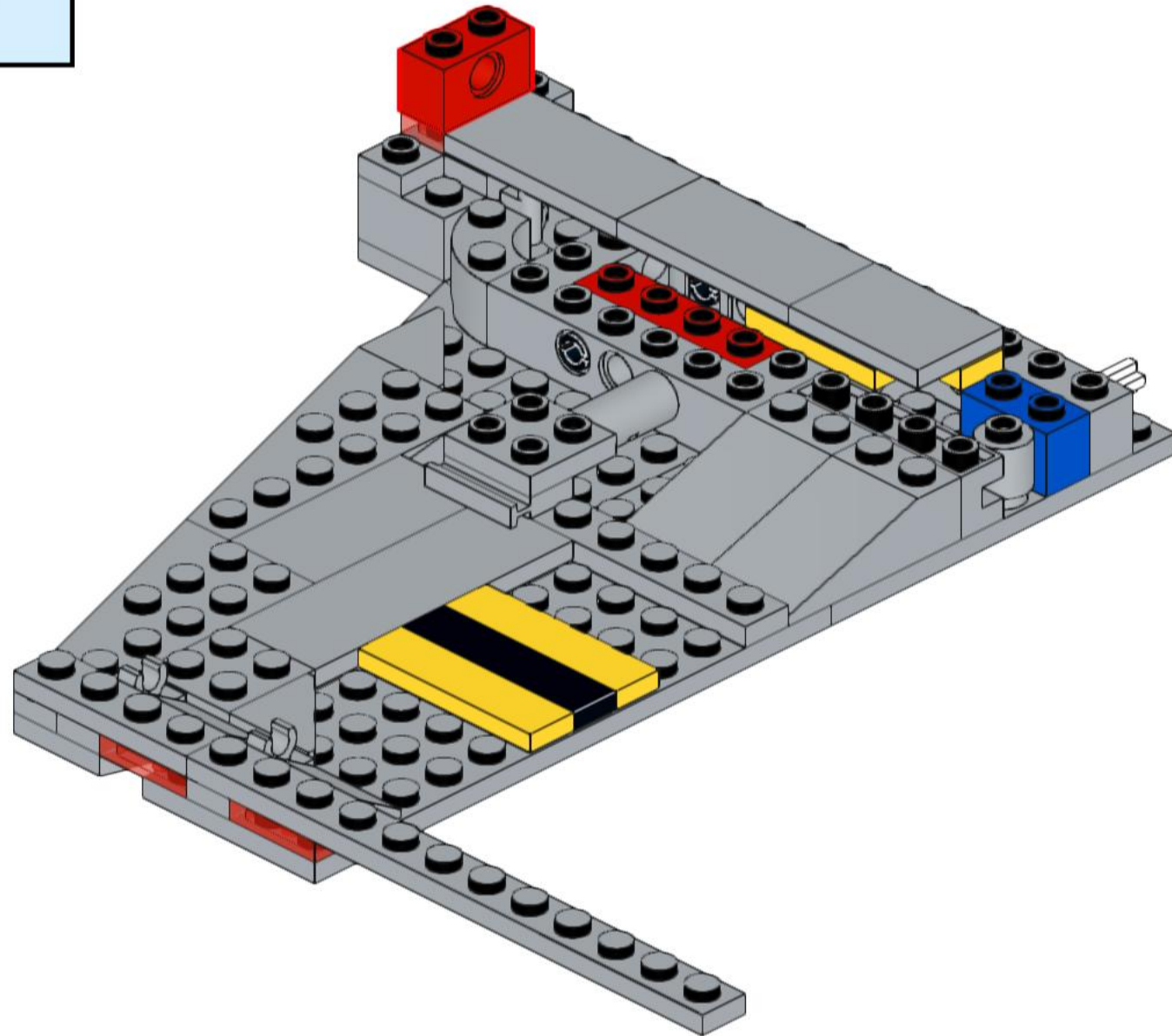
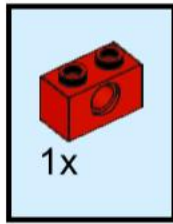

374

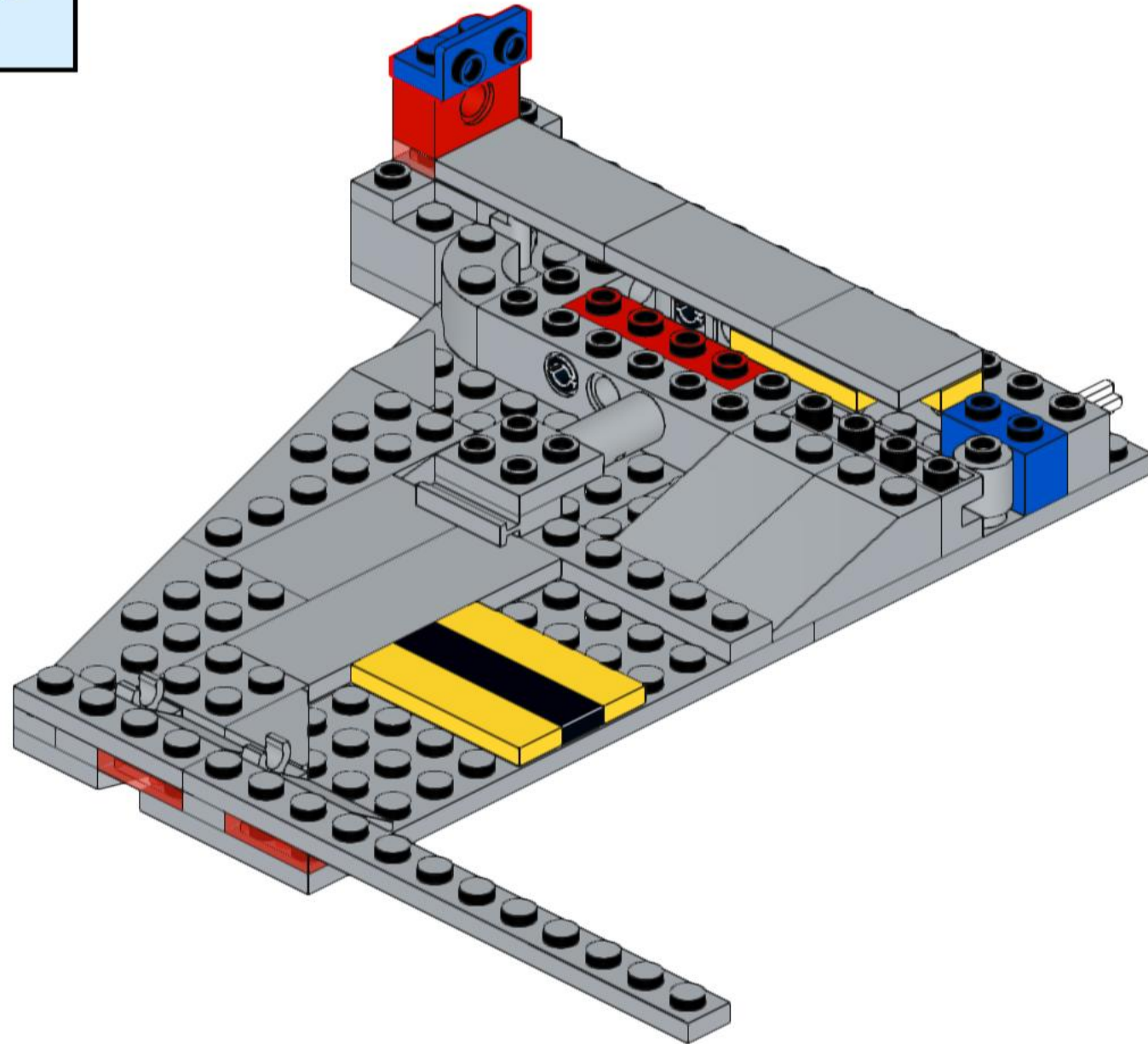
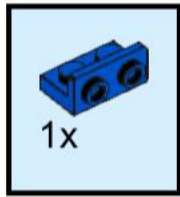

375

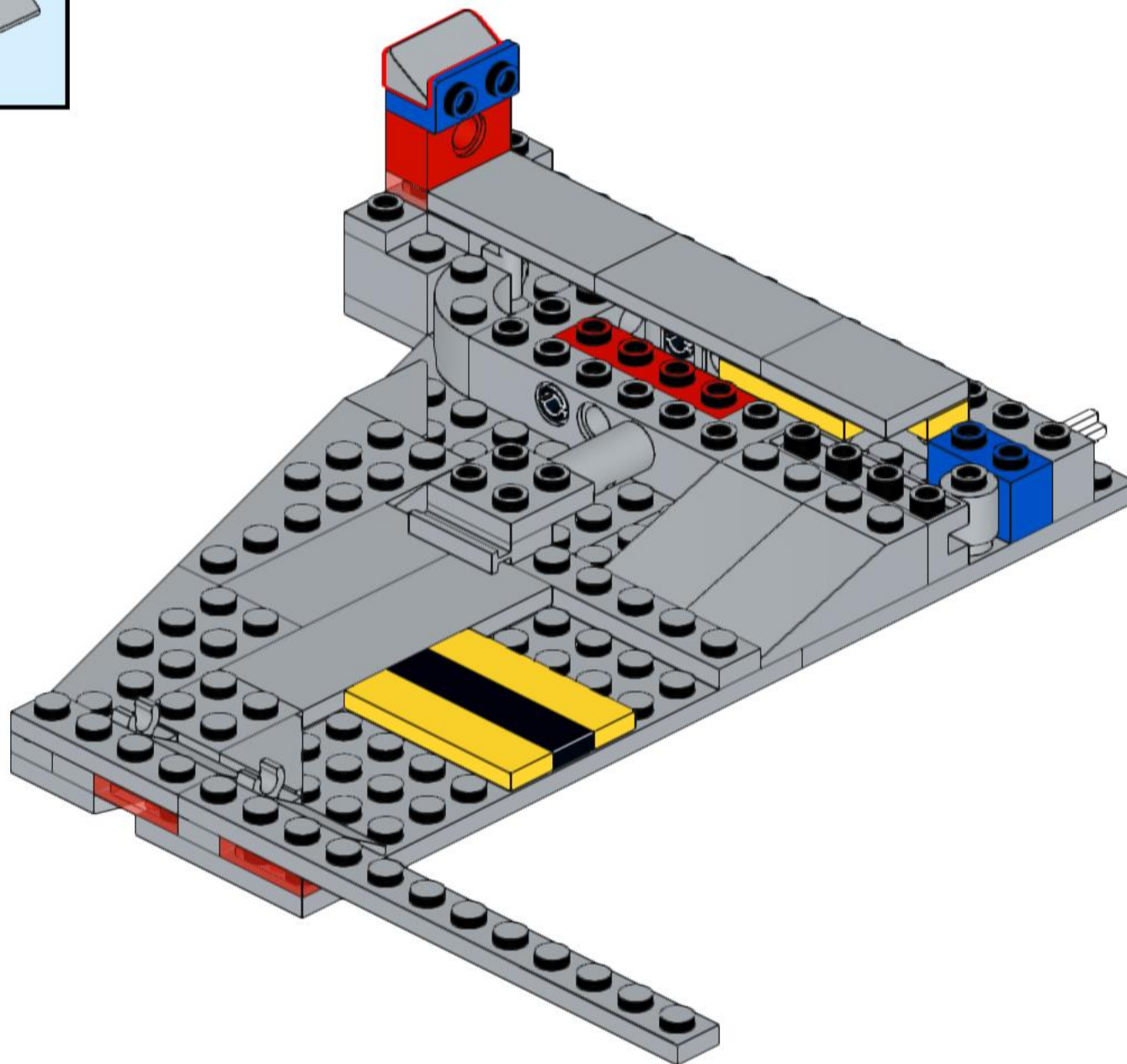
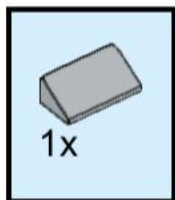

376

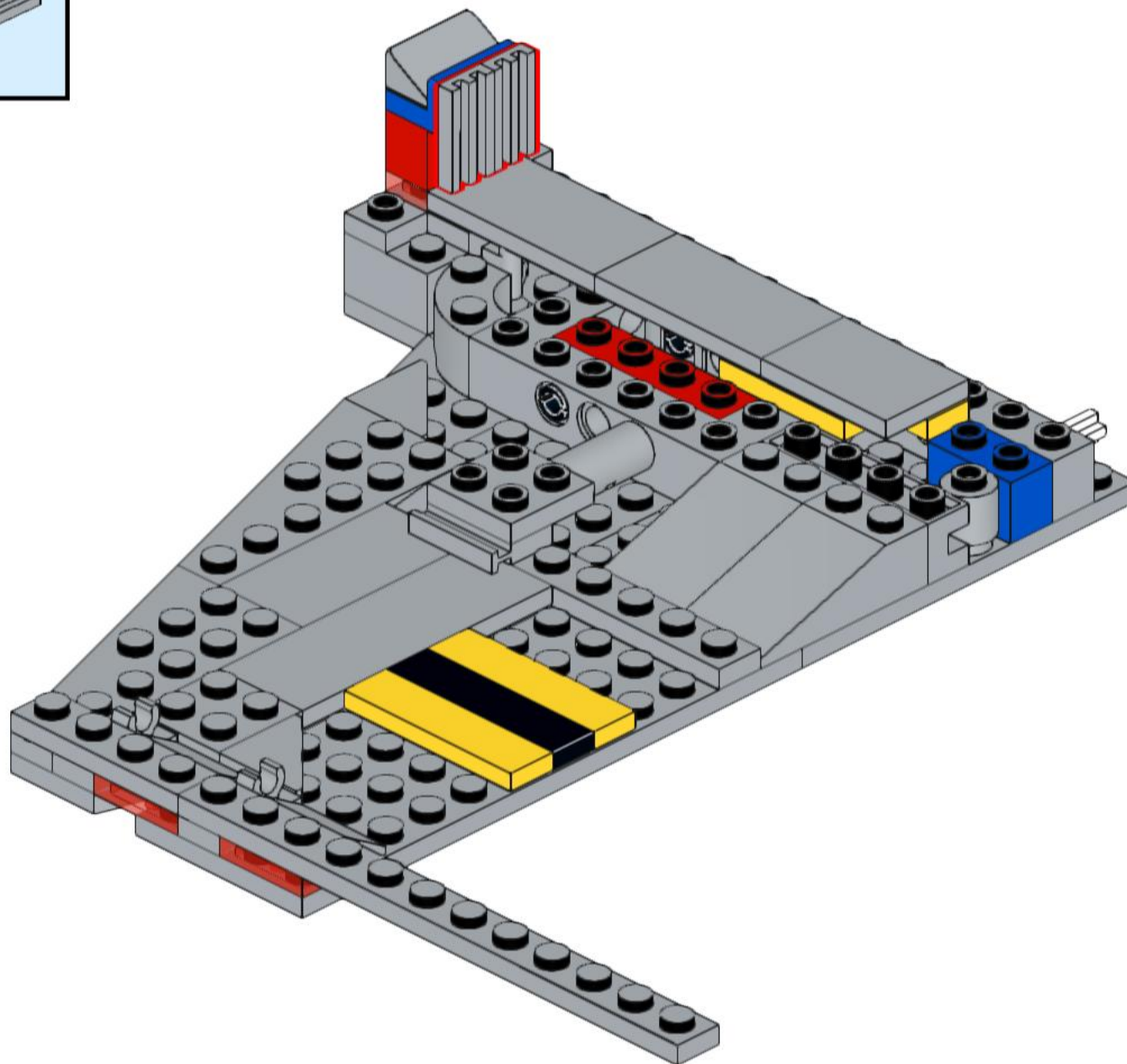
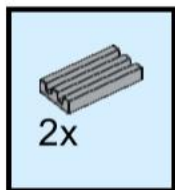

377

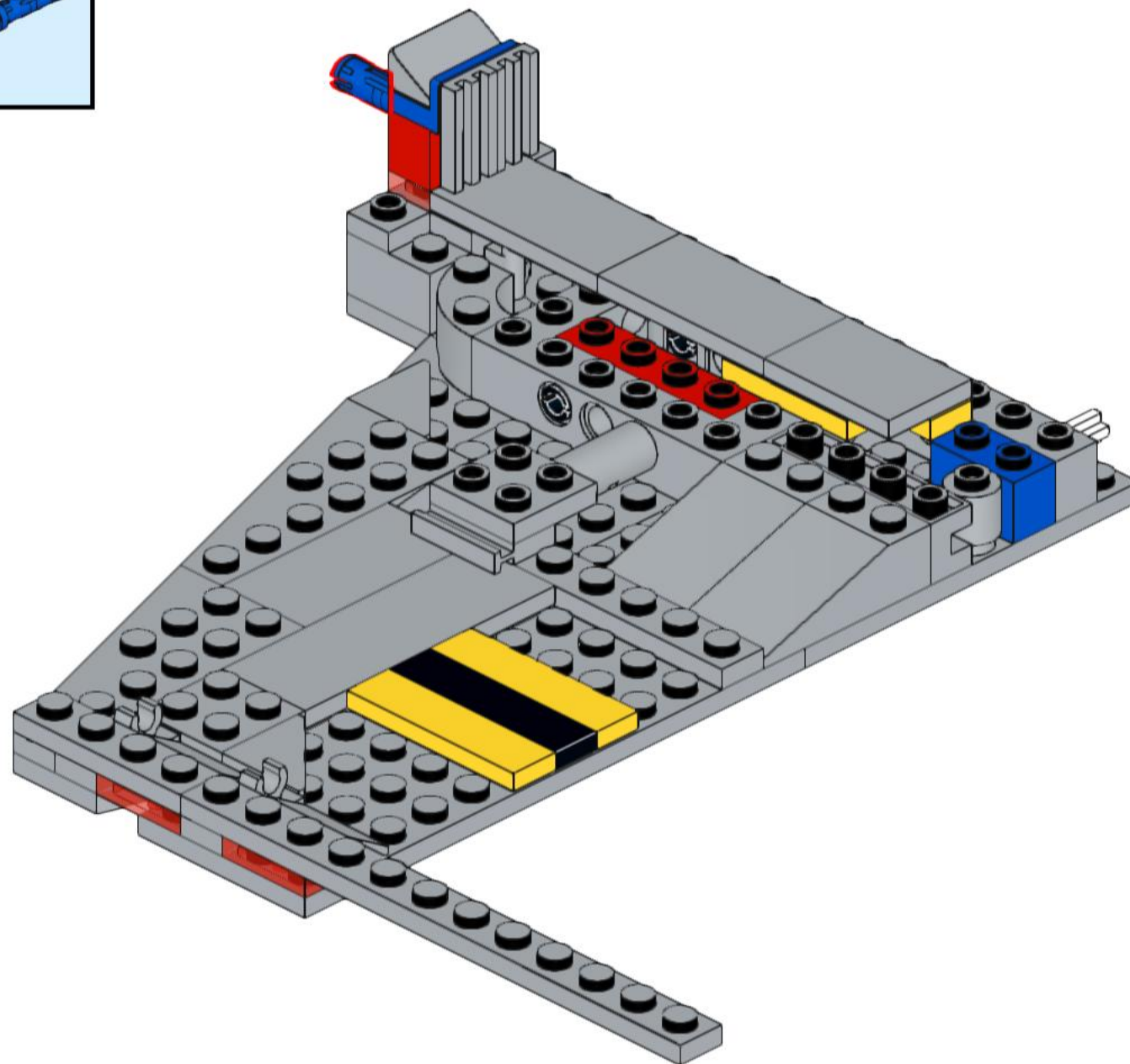
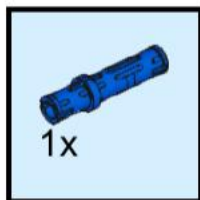

378

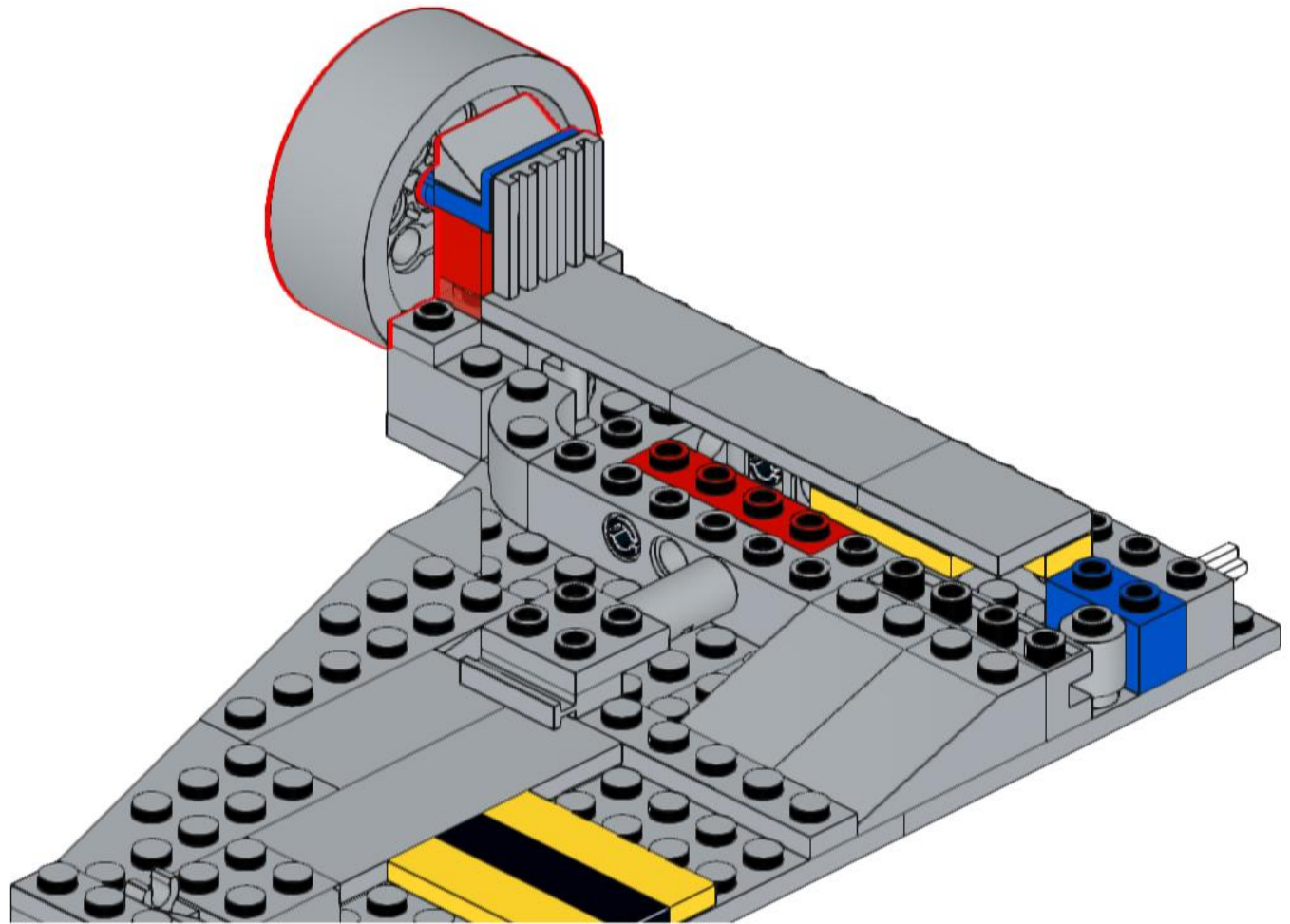
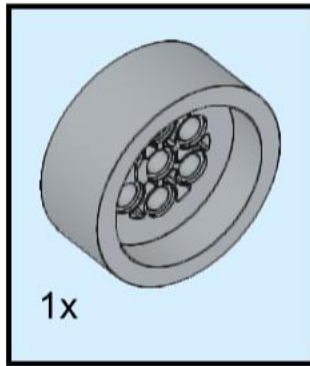

379

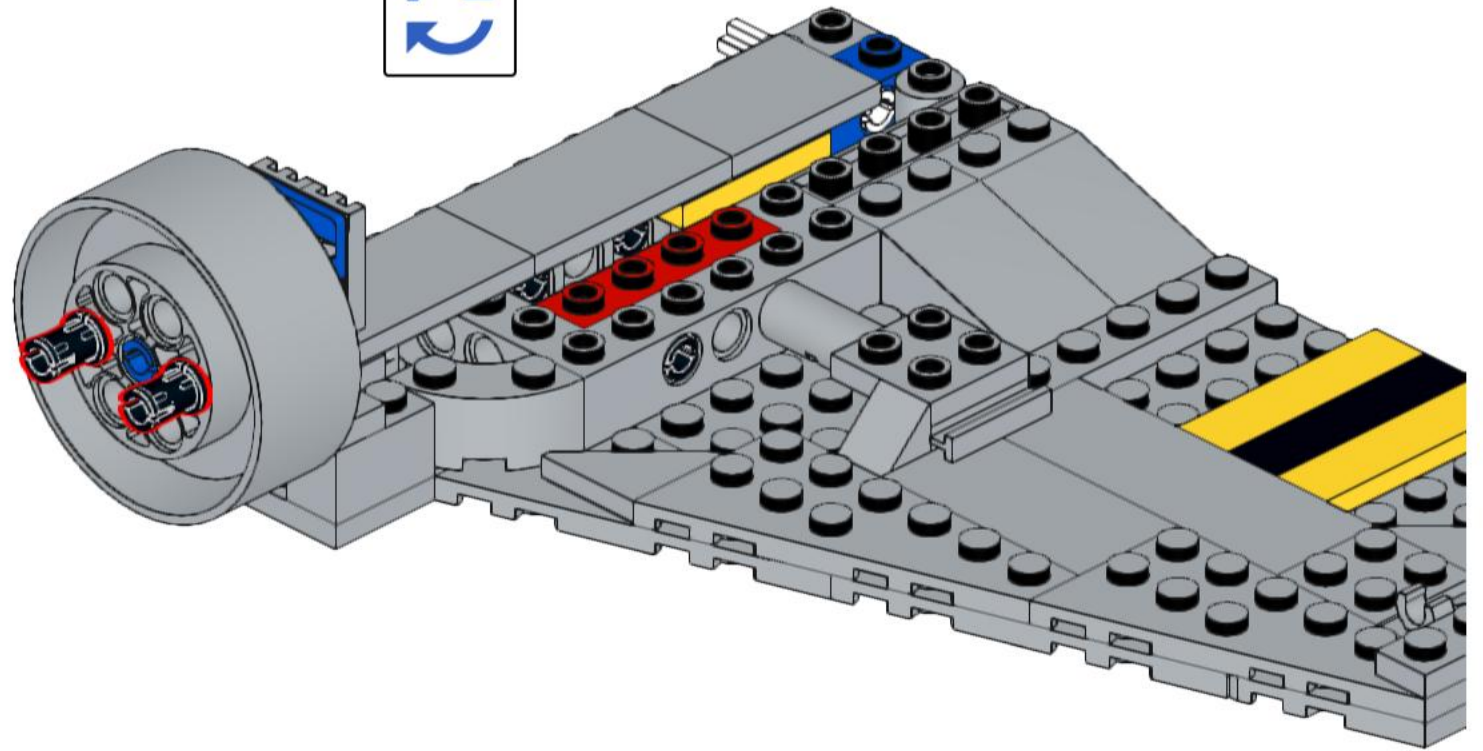

380

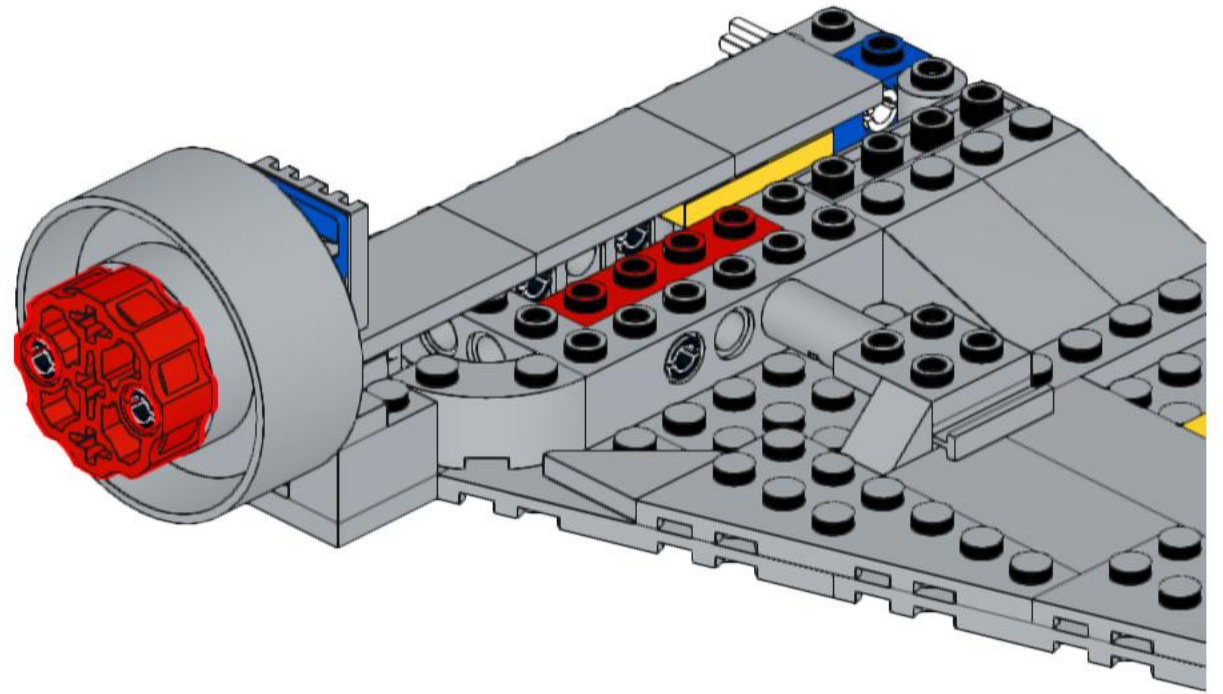
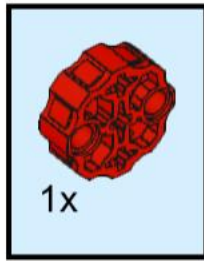

381

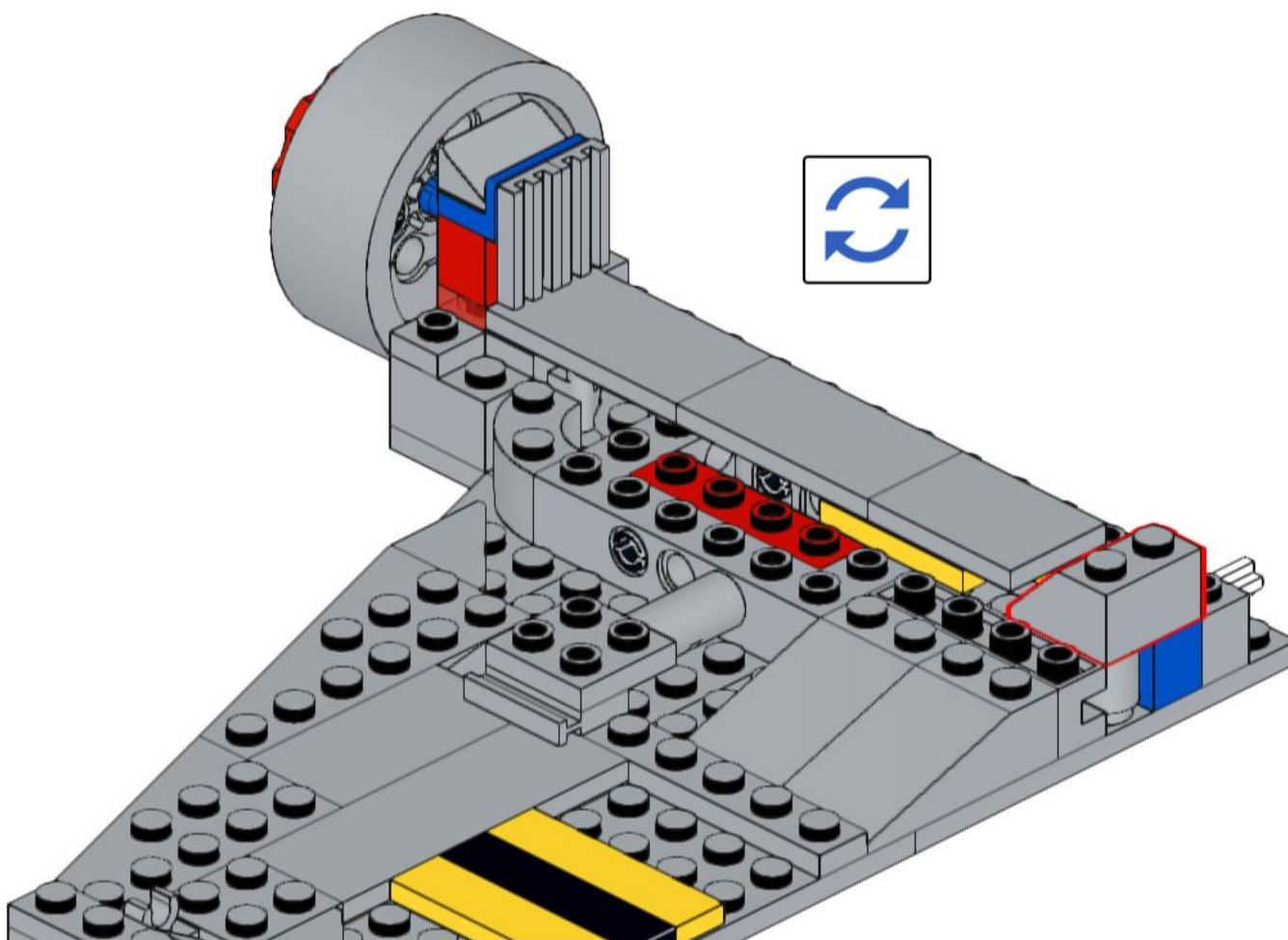
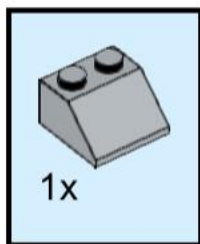

382

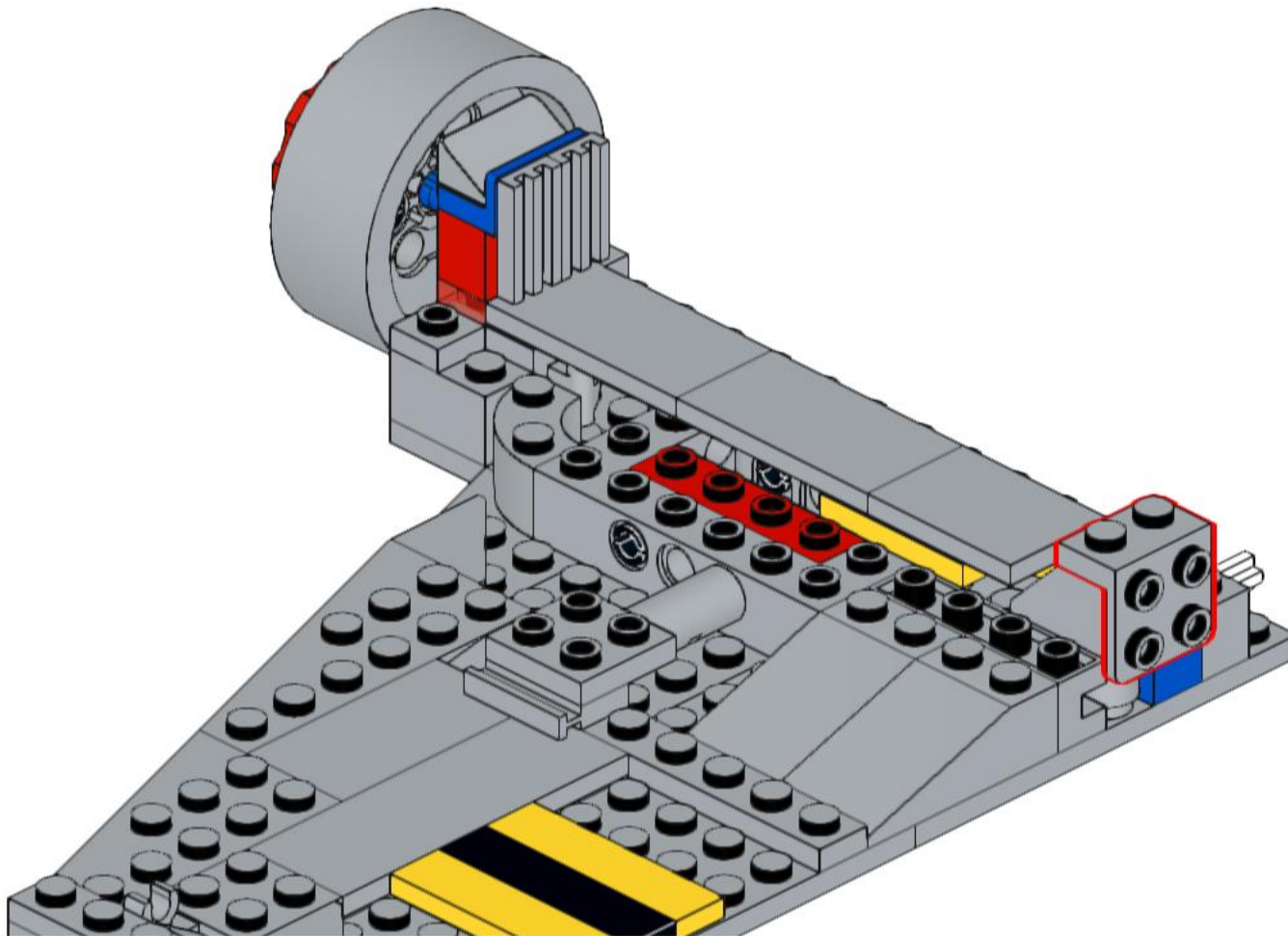
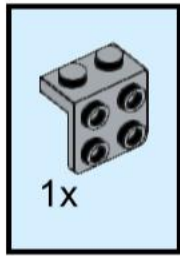

383

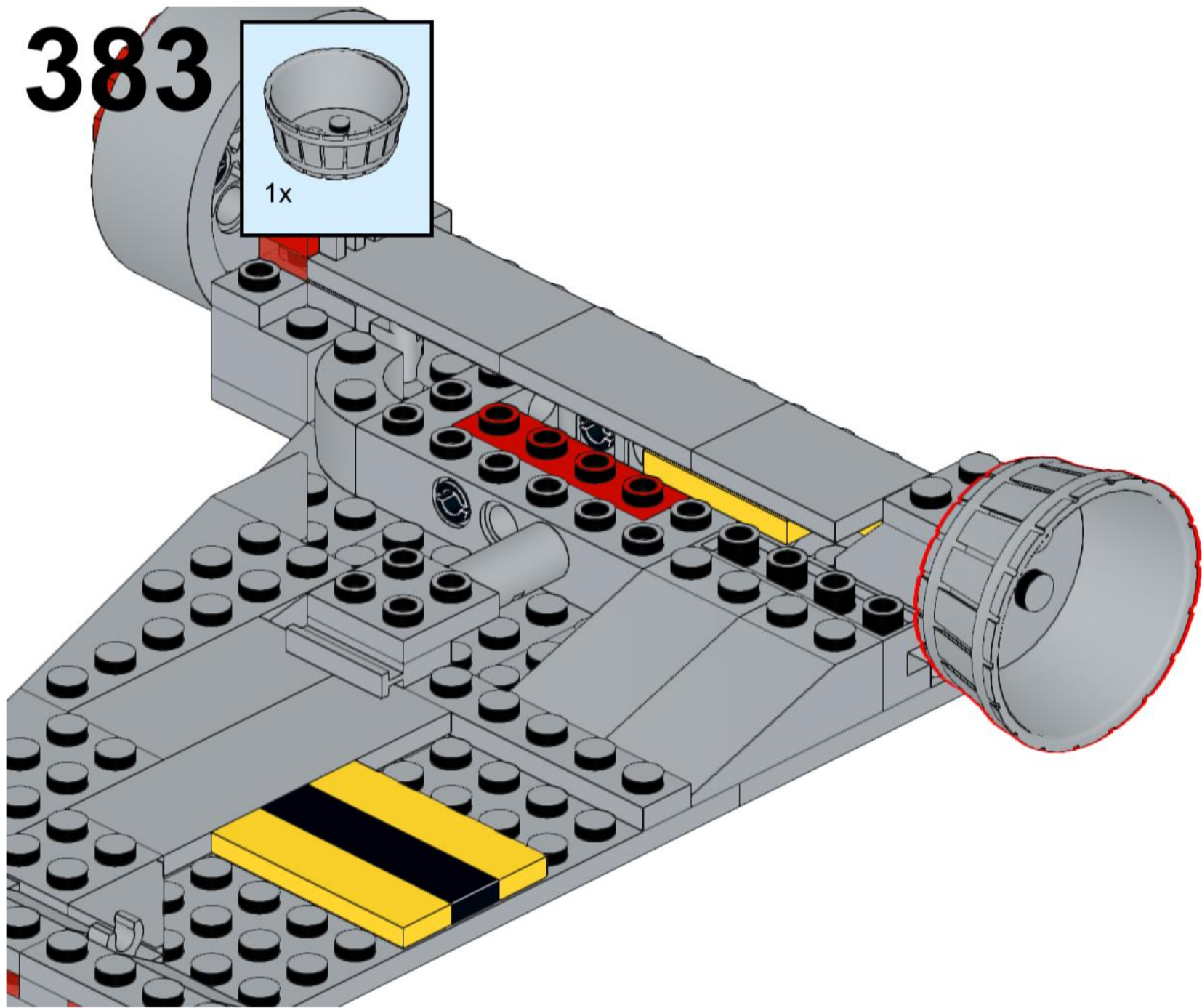
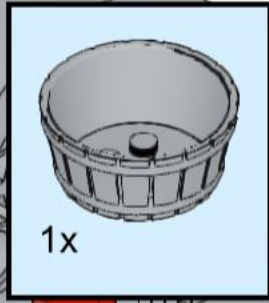

384

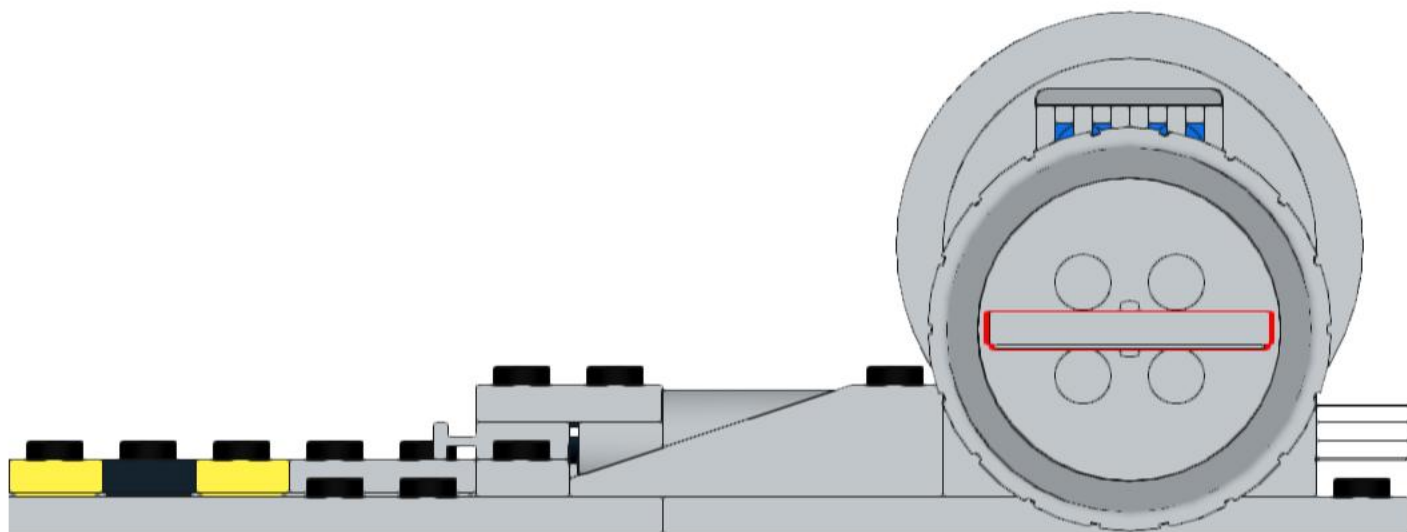
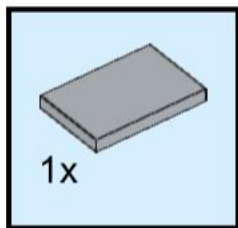

385

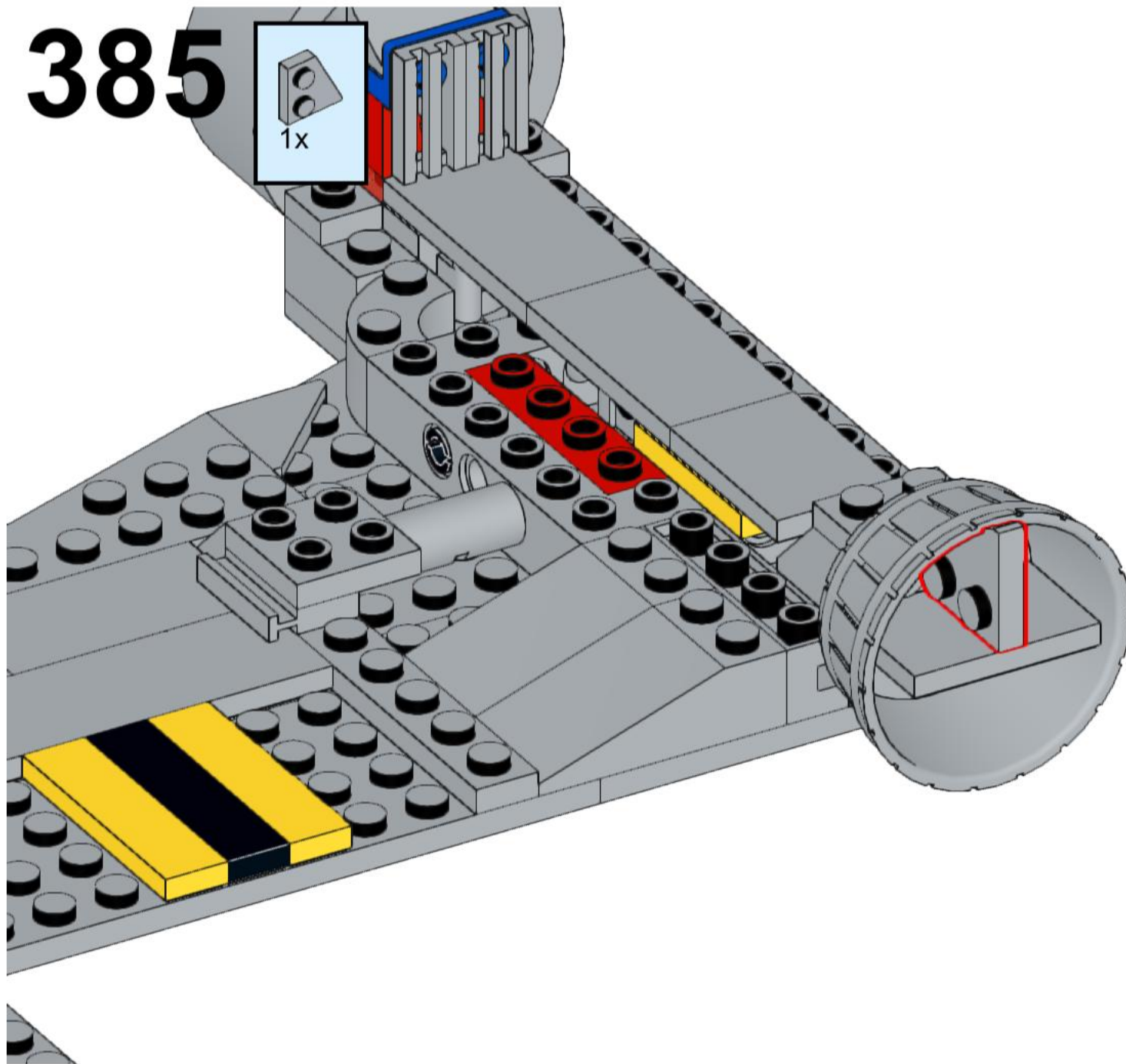
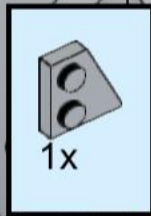

386

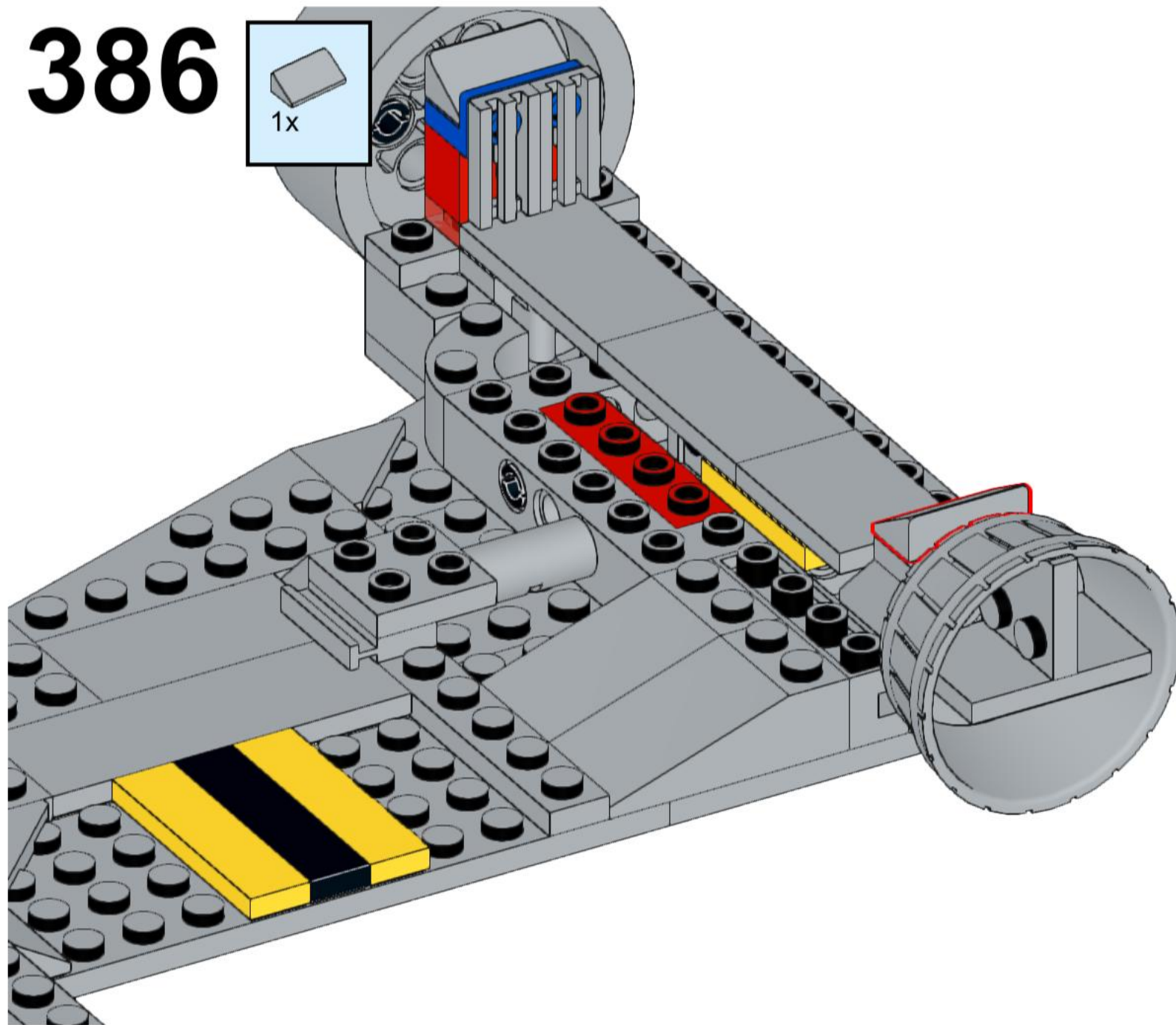
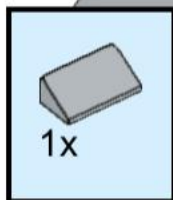

387

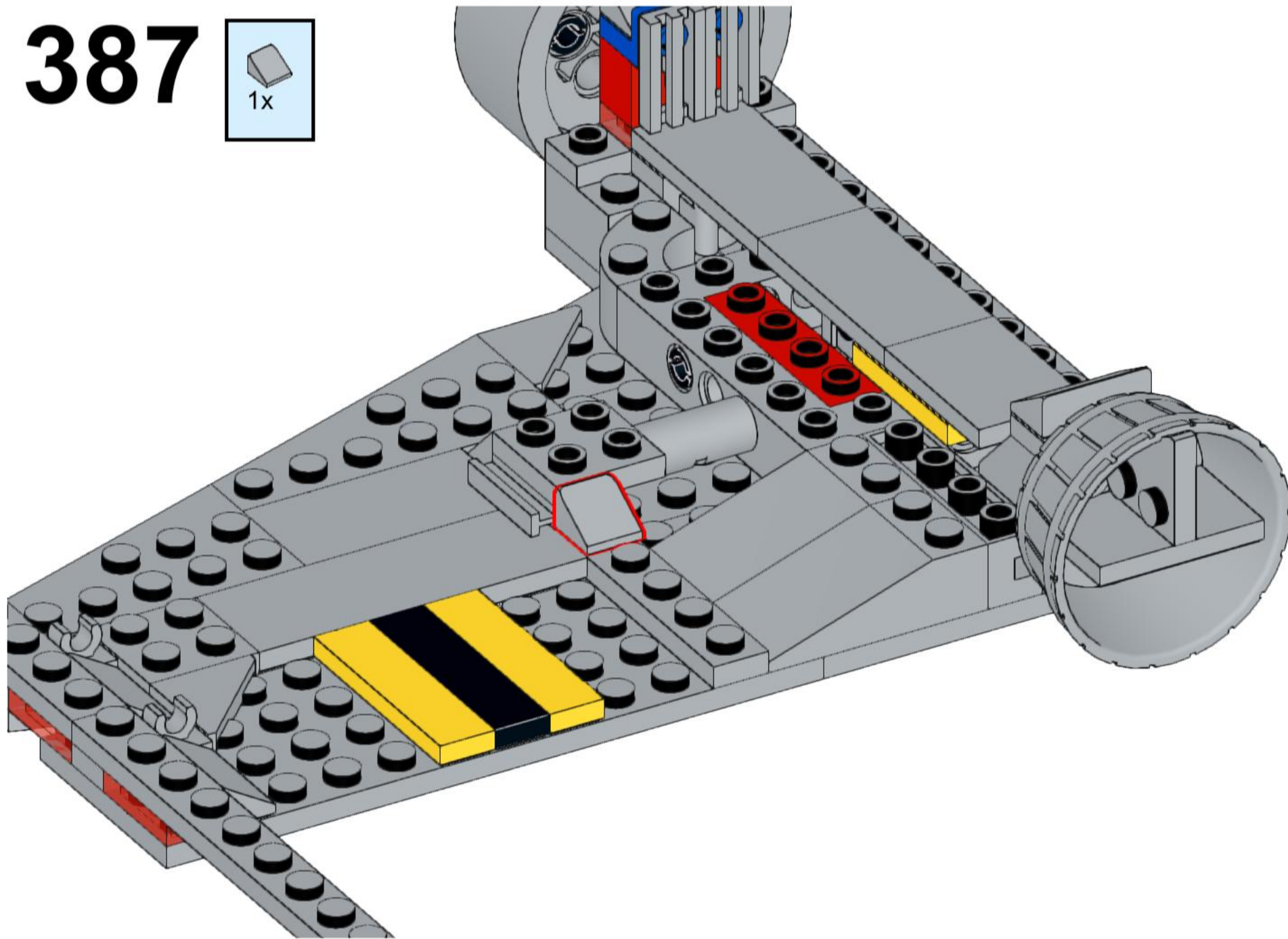
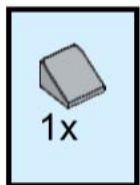

388

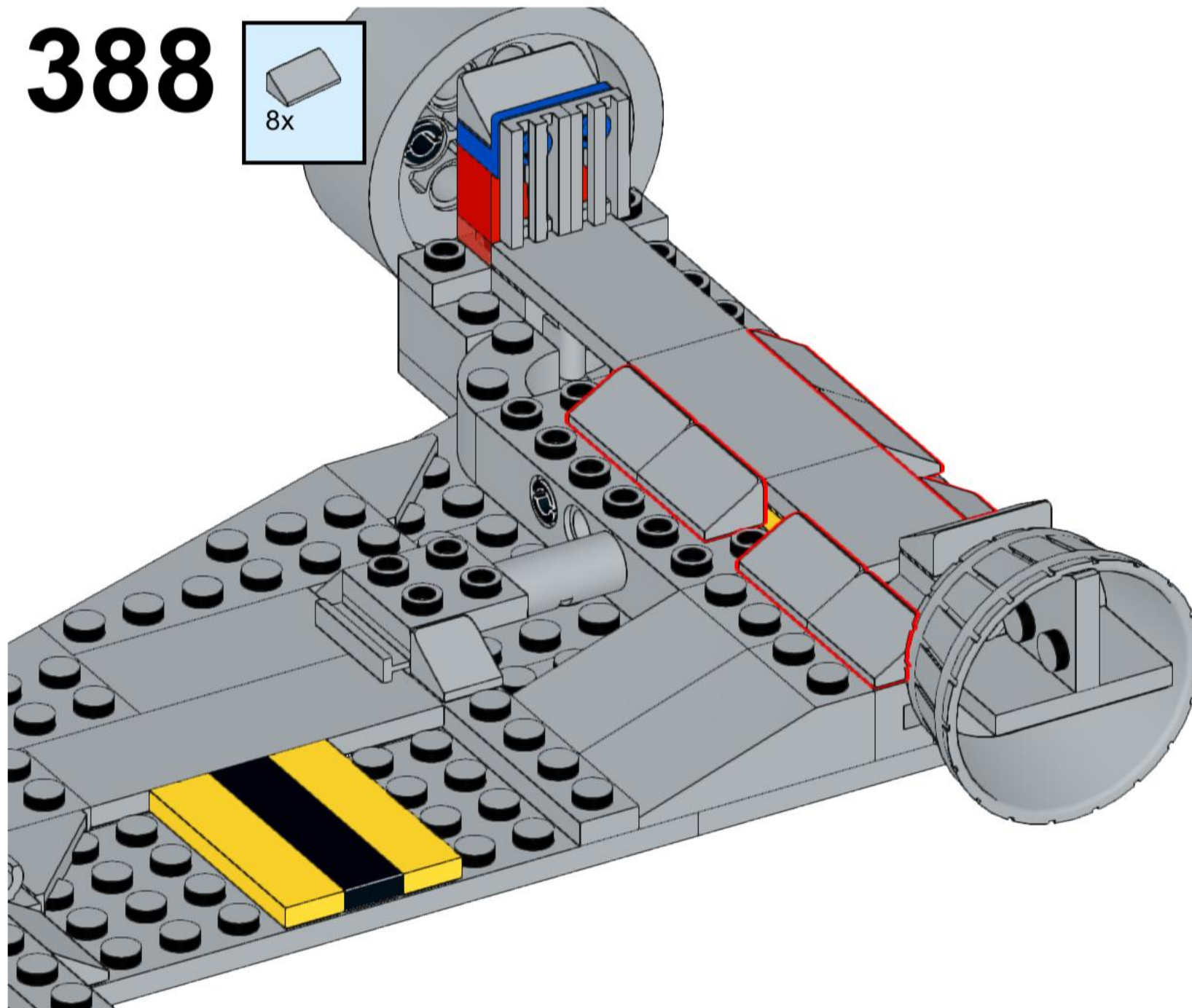
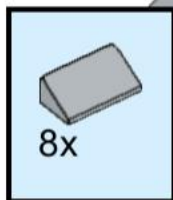

389

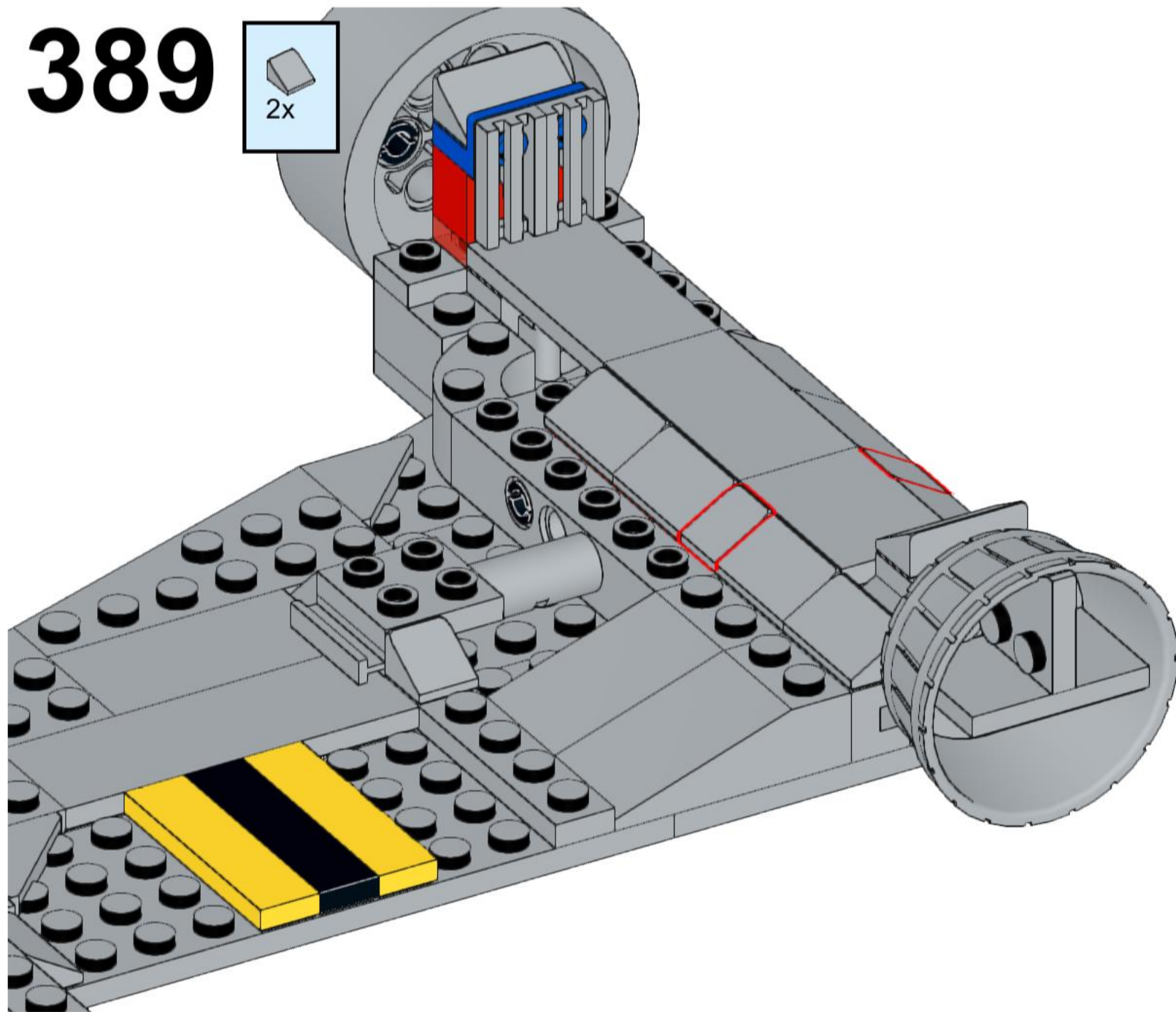
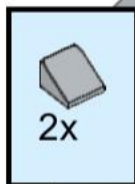

390

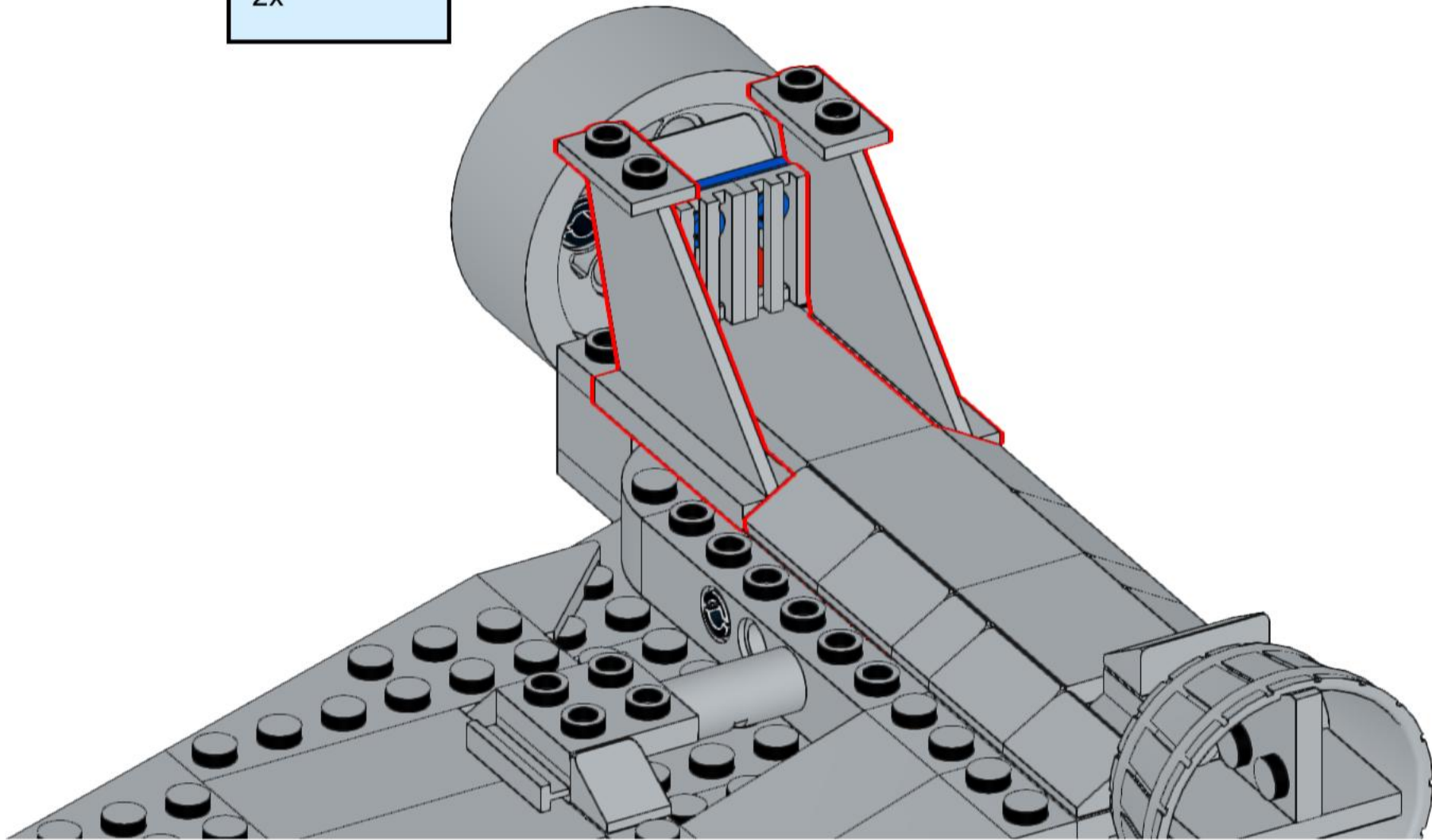
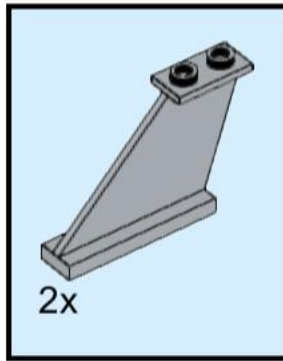

391

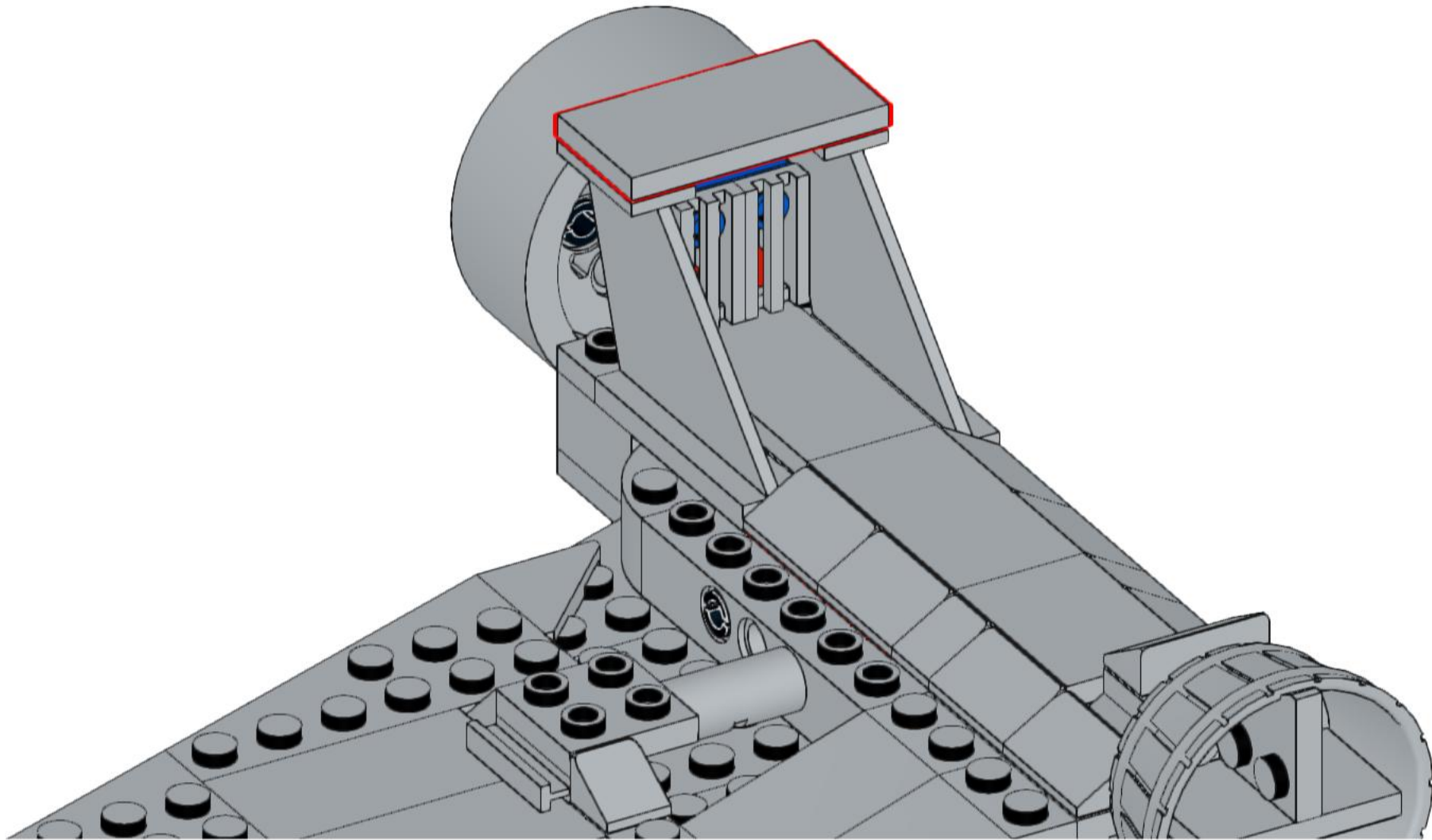
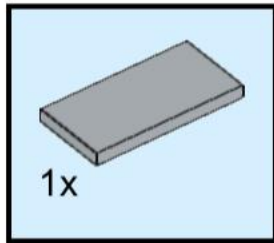

392

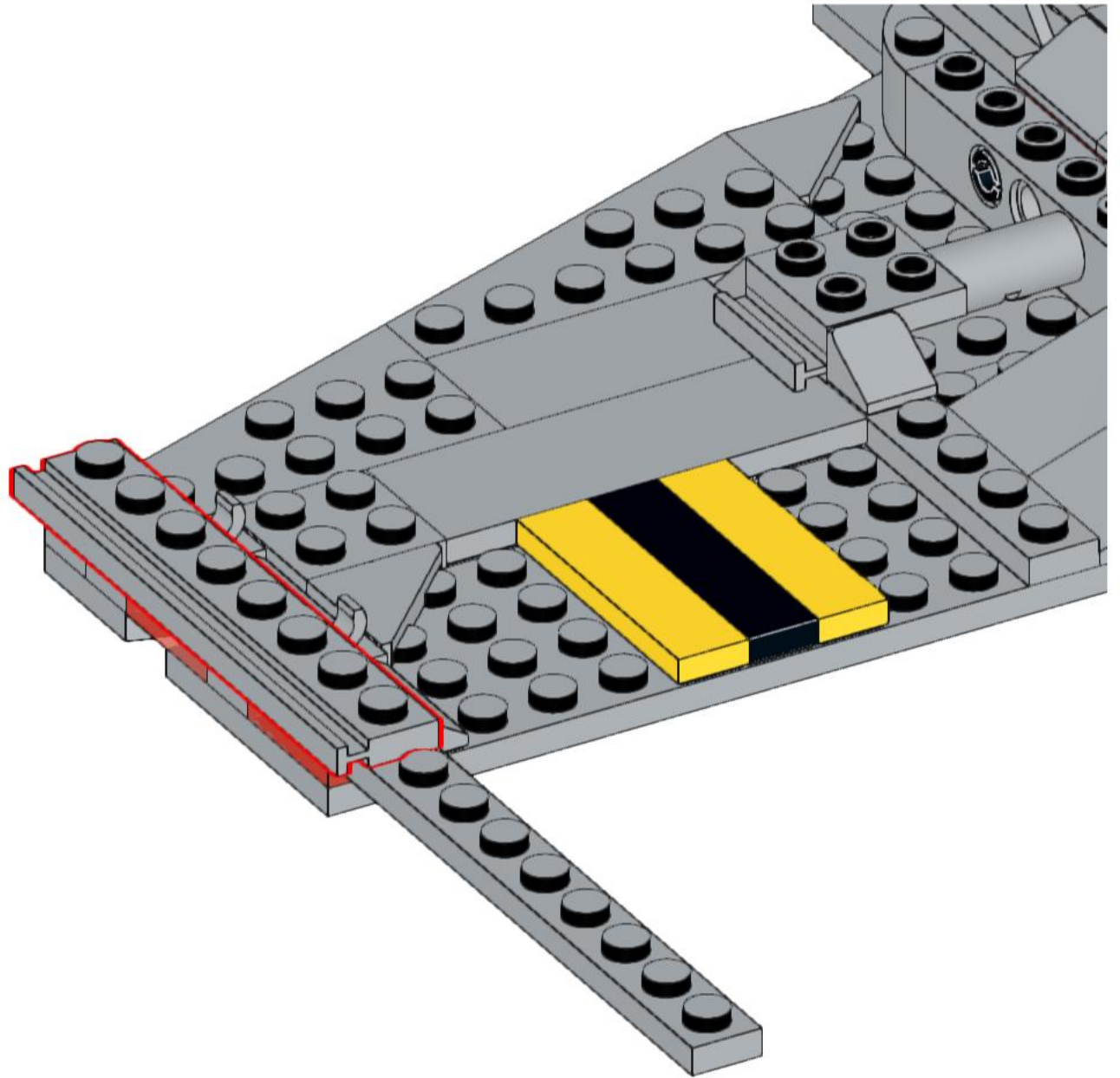
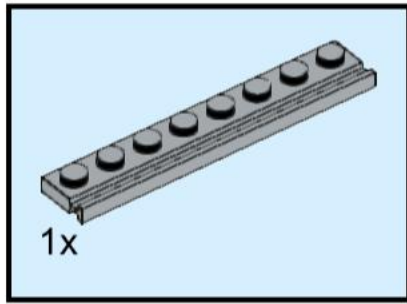

393

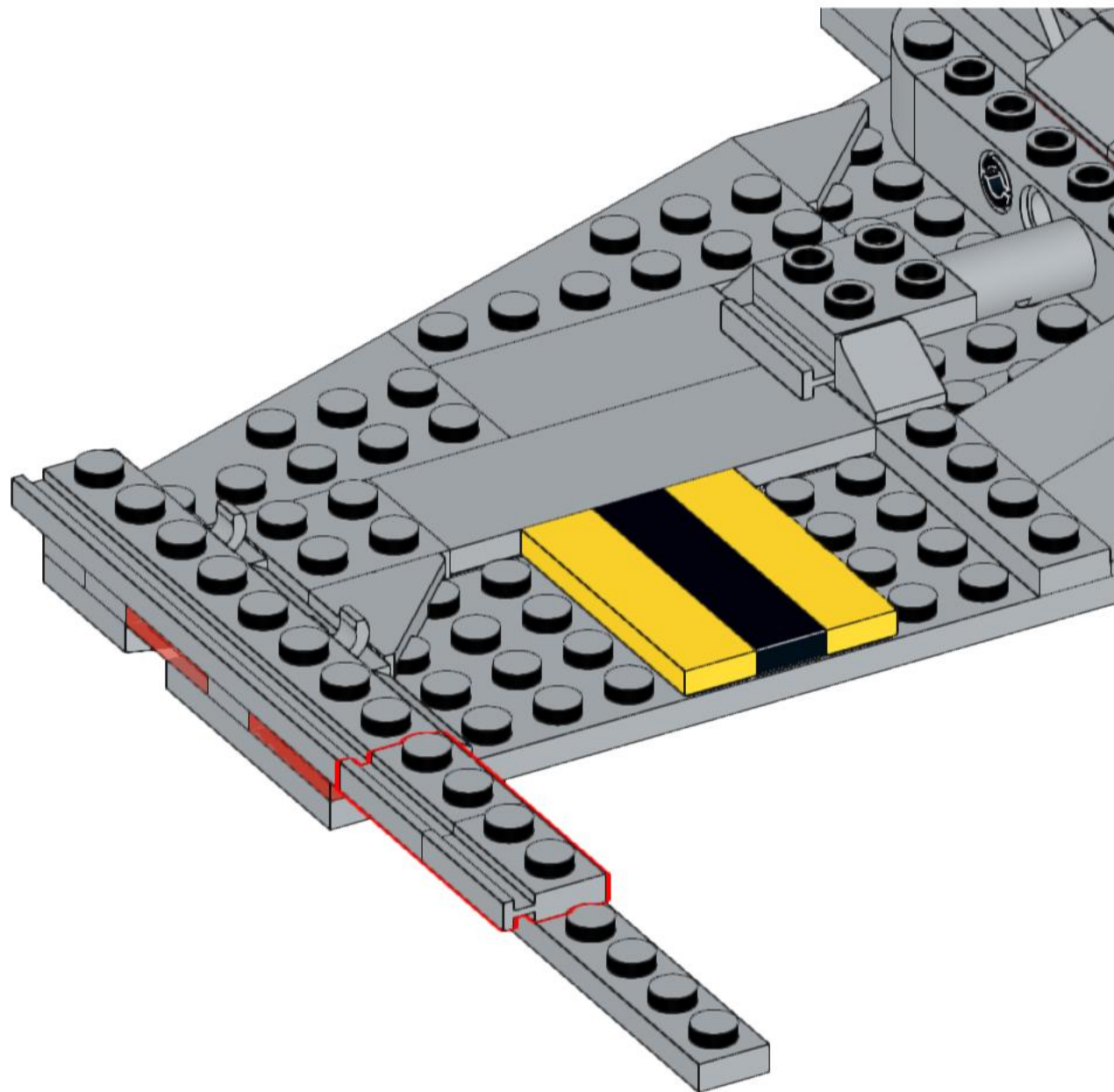
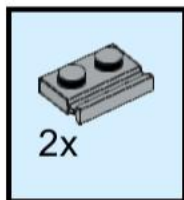

394

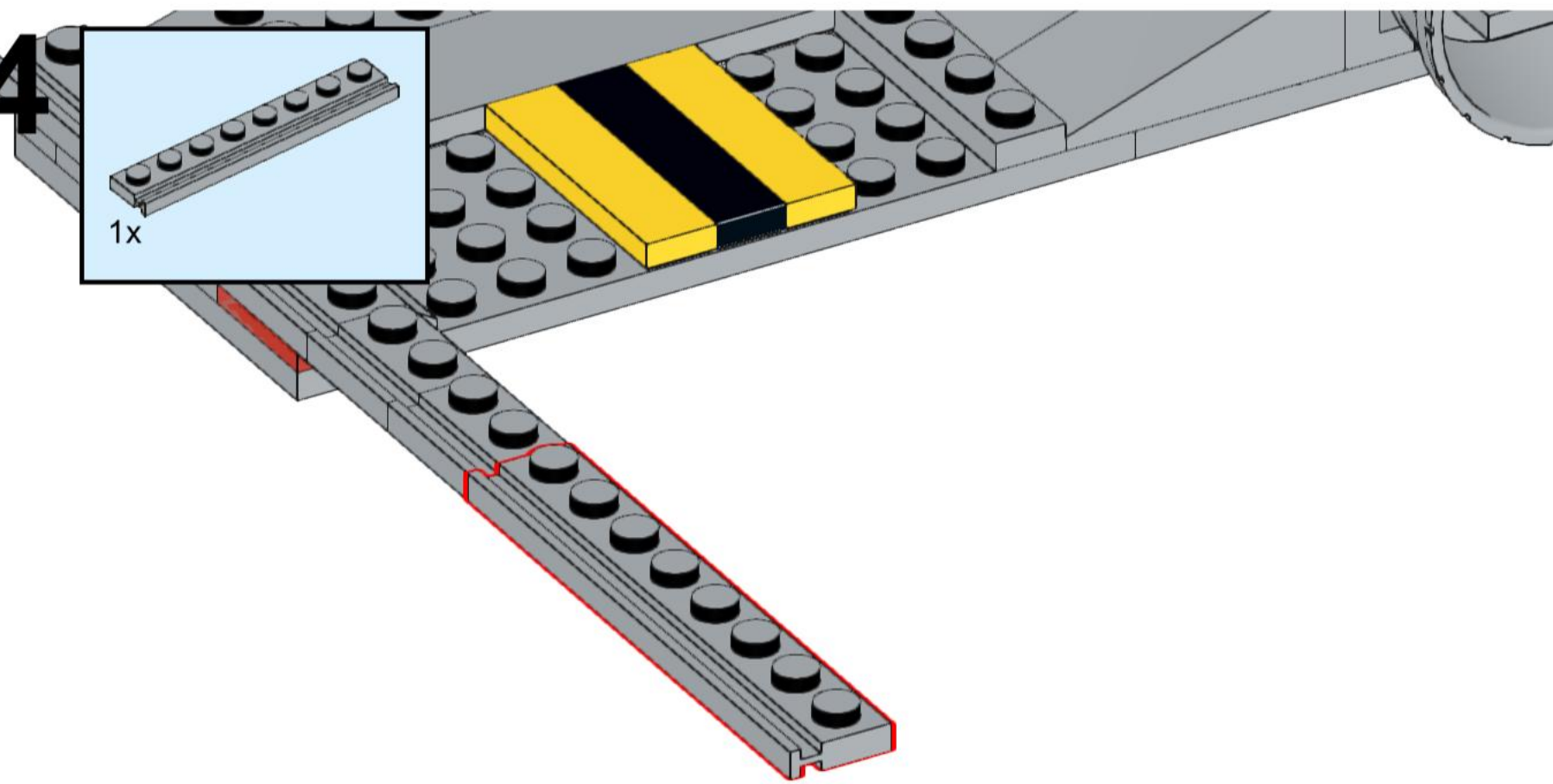
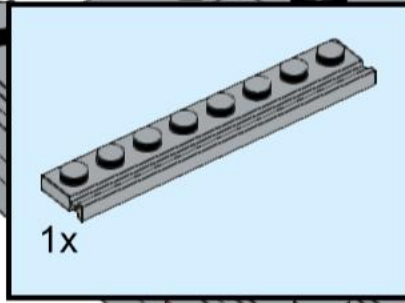

395

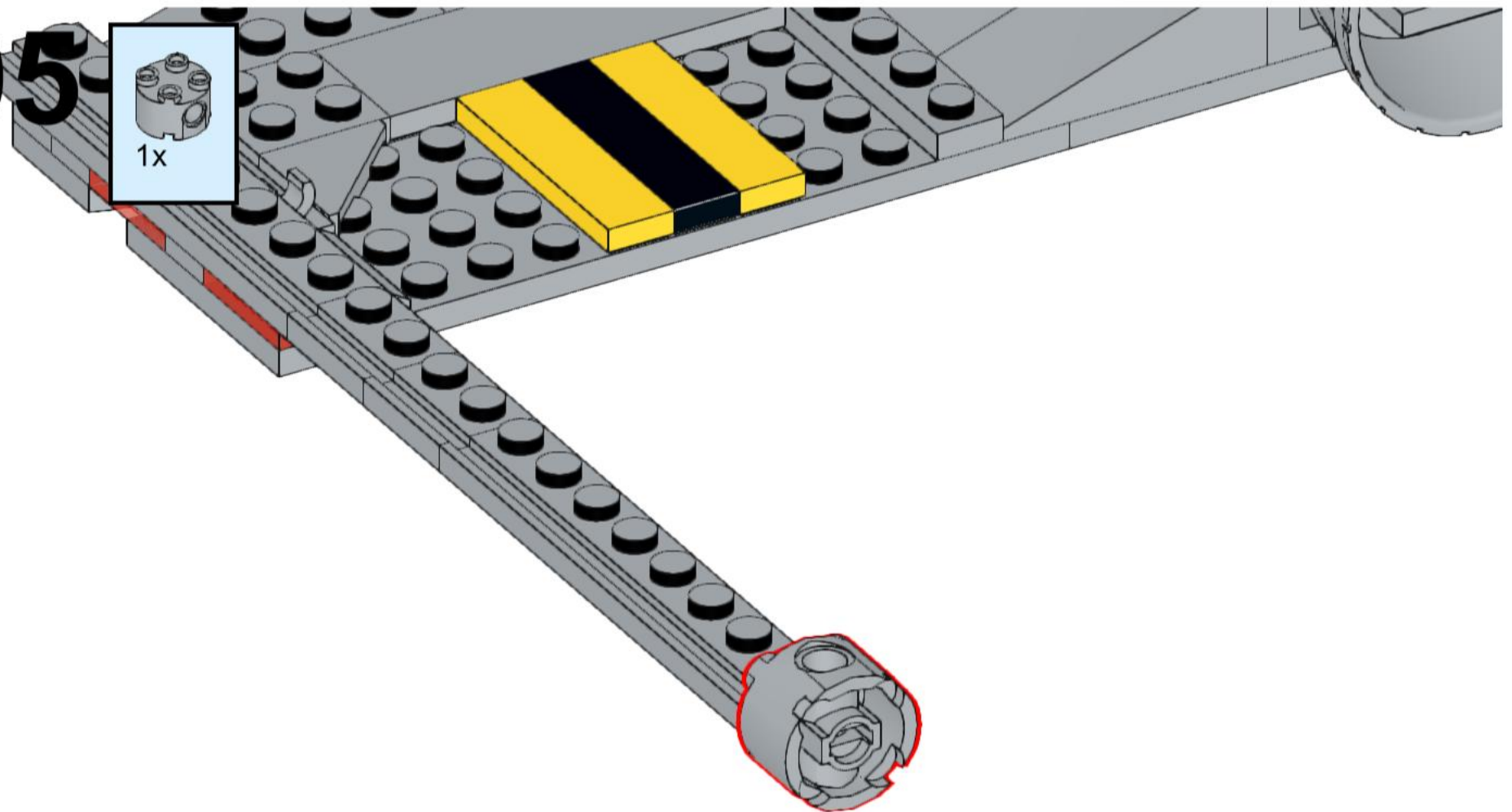
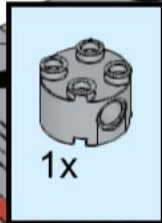

Another tricky connection. Try placing the round brick sideways on the table, and pushing the tail through the studs. This should give you a solid connection. It should look like this.

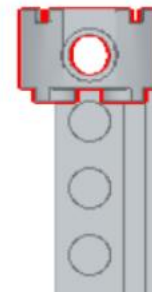

396

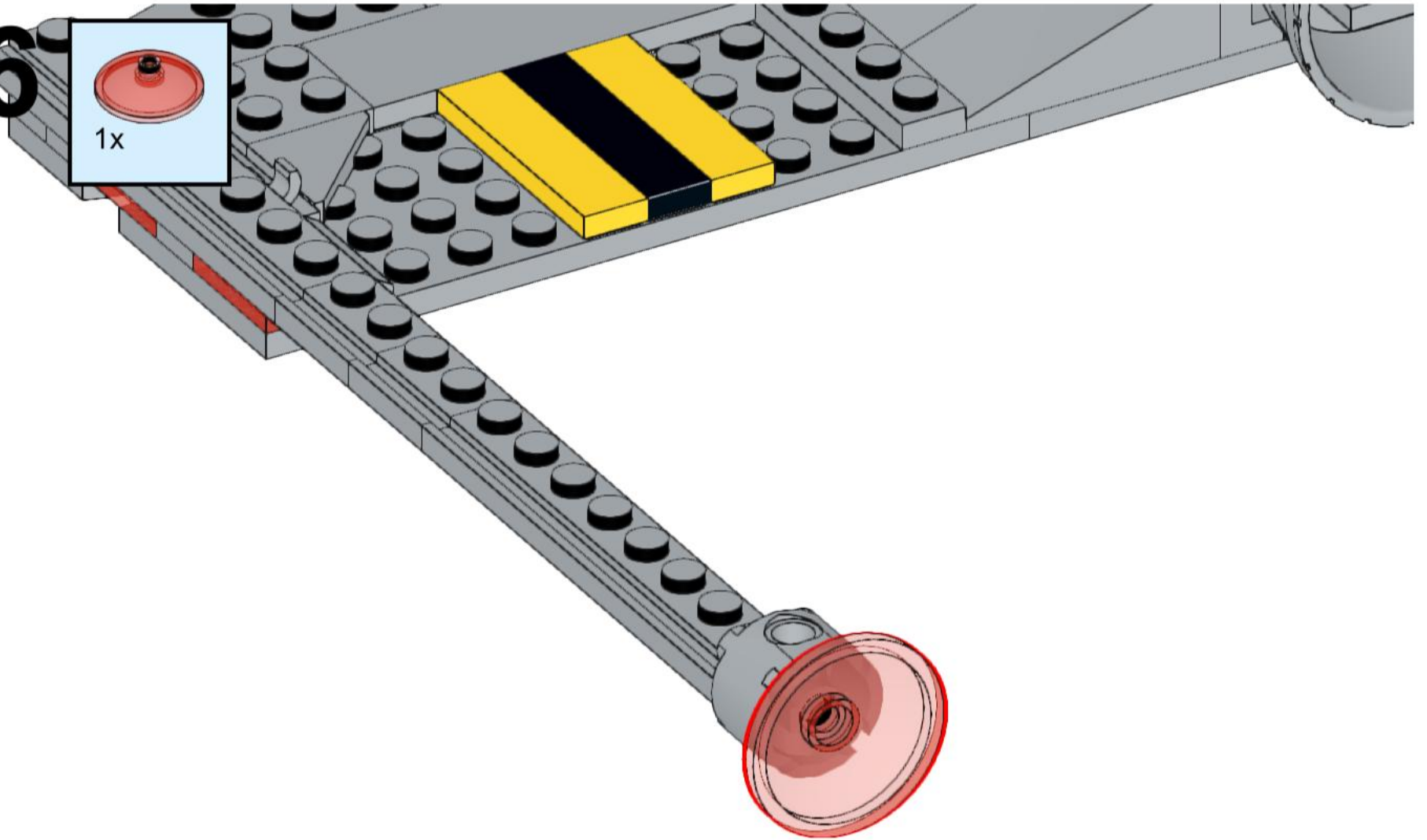
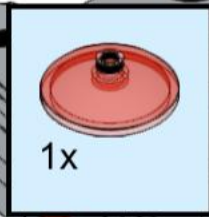

39

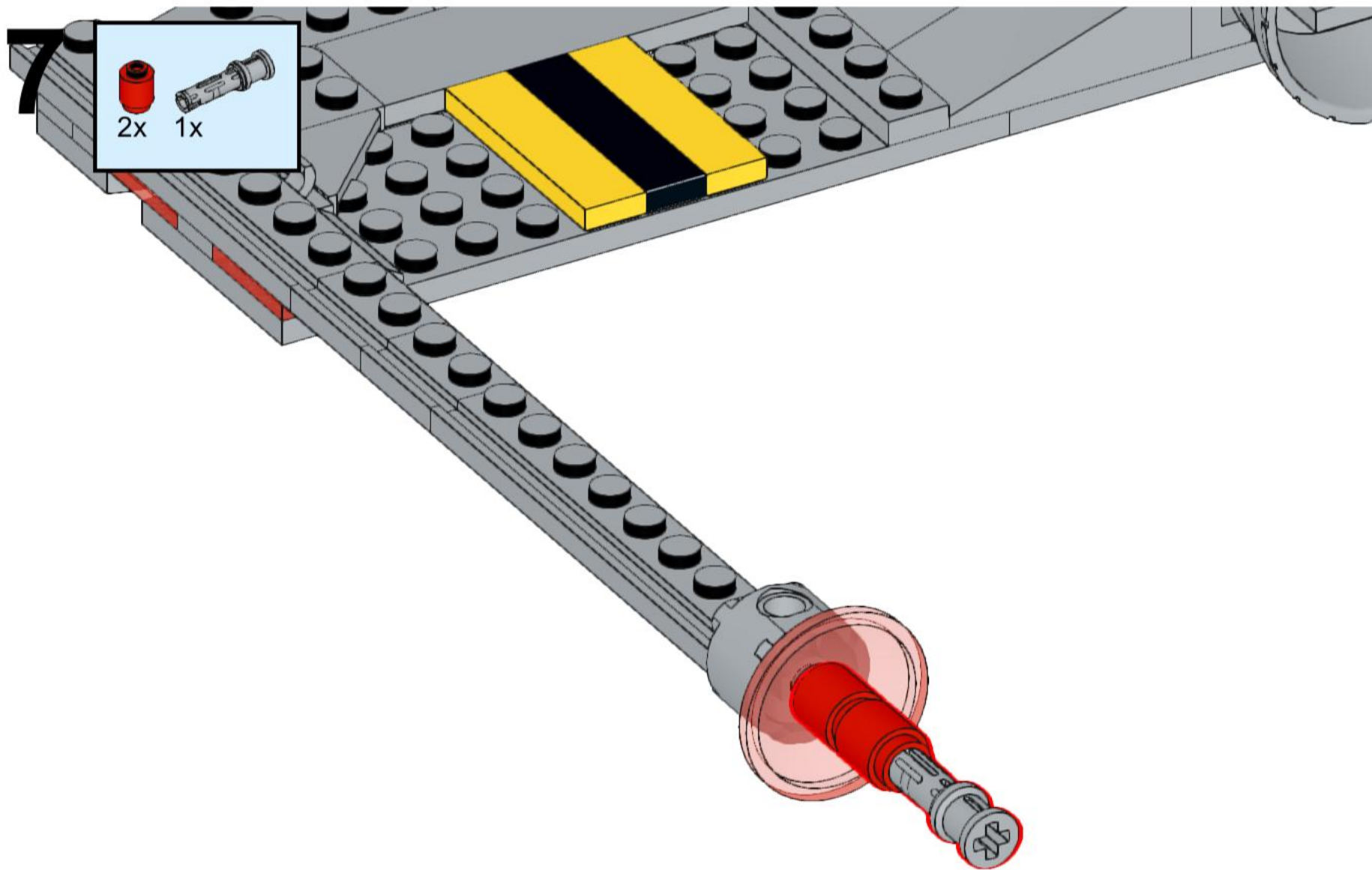
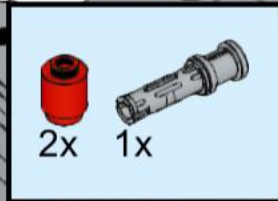

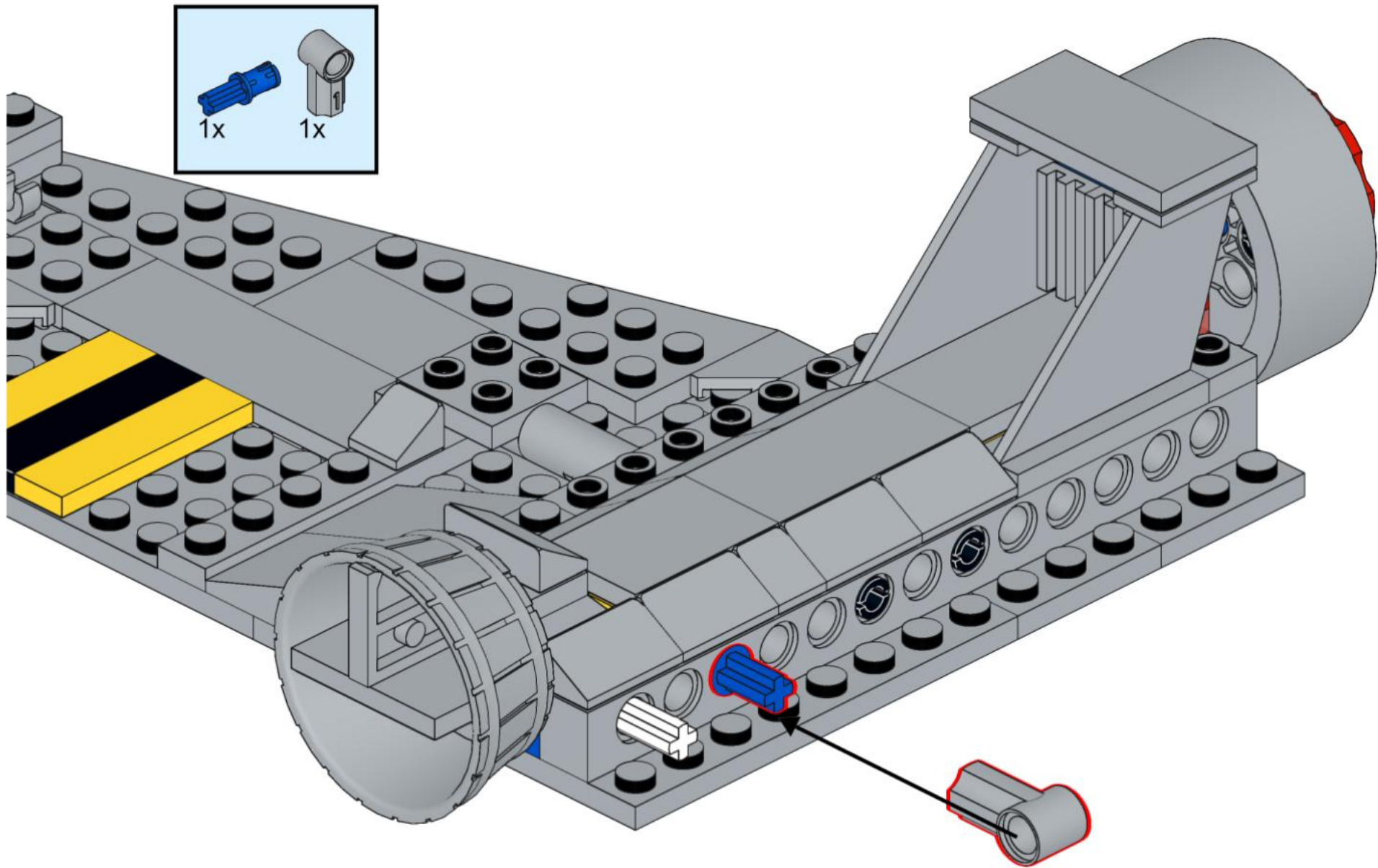

These two pieces need to be attached to *ONE* wing only, that being the *TOP* wing.

398

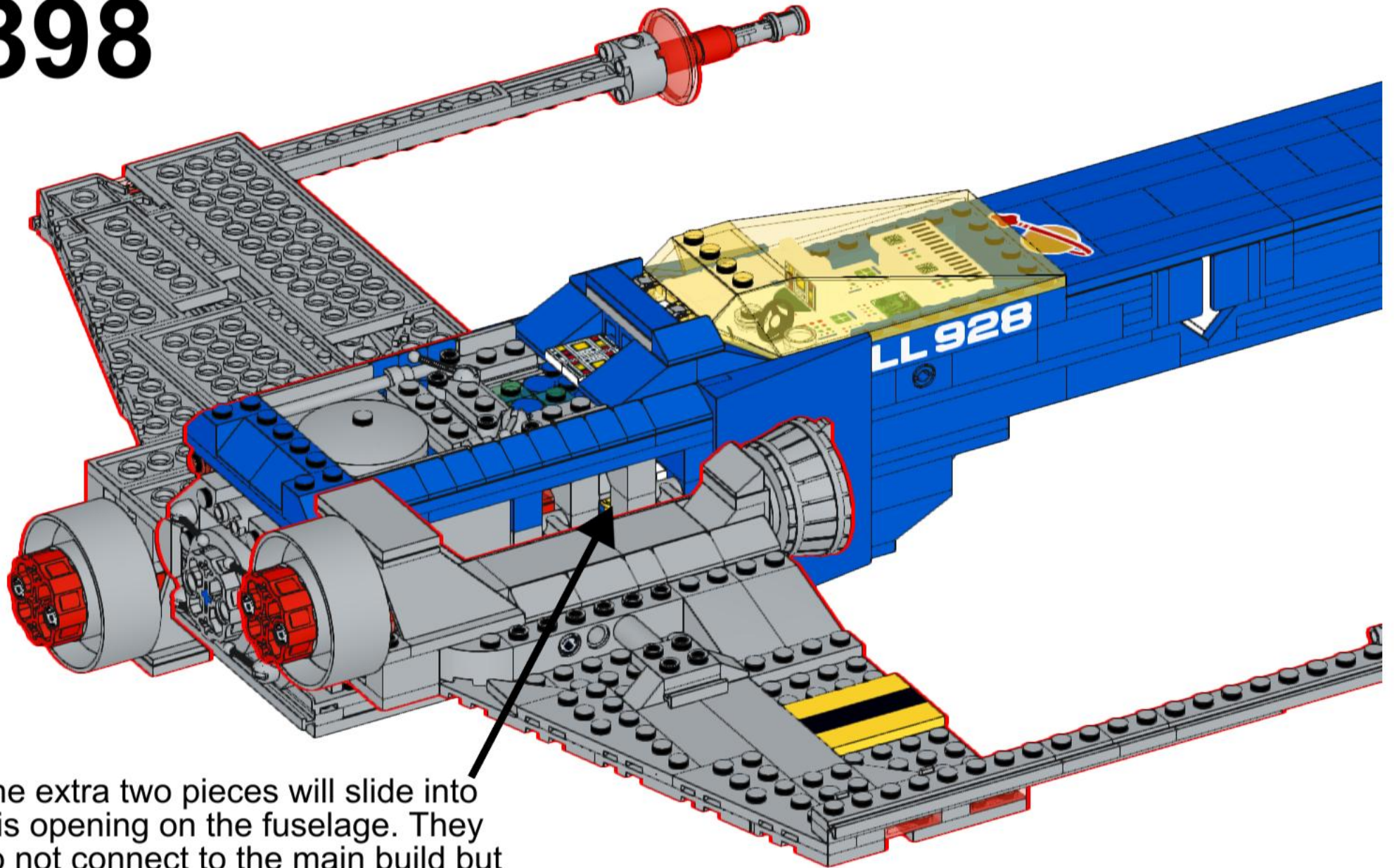

The extra two pieces will slide into this opening on the fuselage. They do not connect to the main build but instead provide stability to the wing.

399

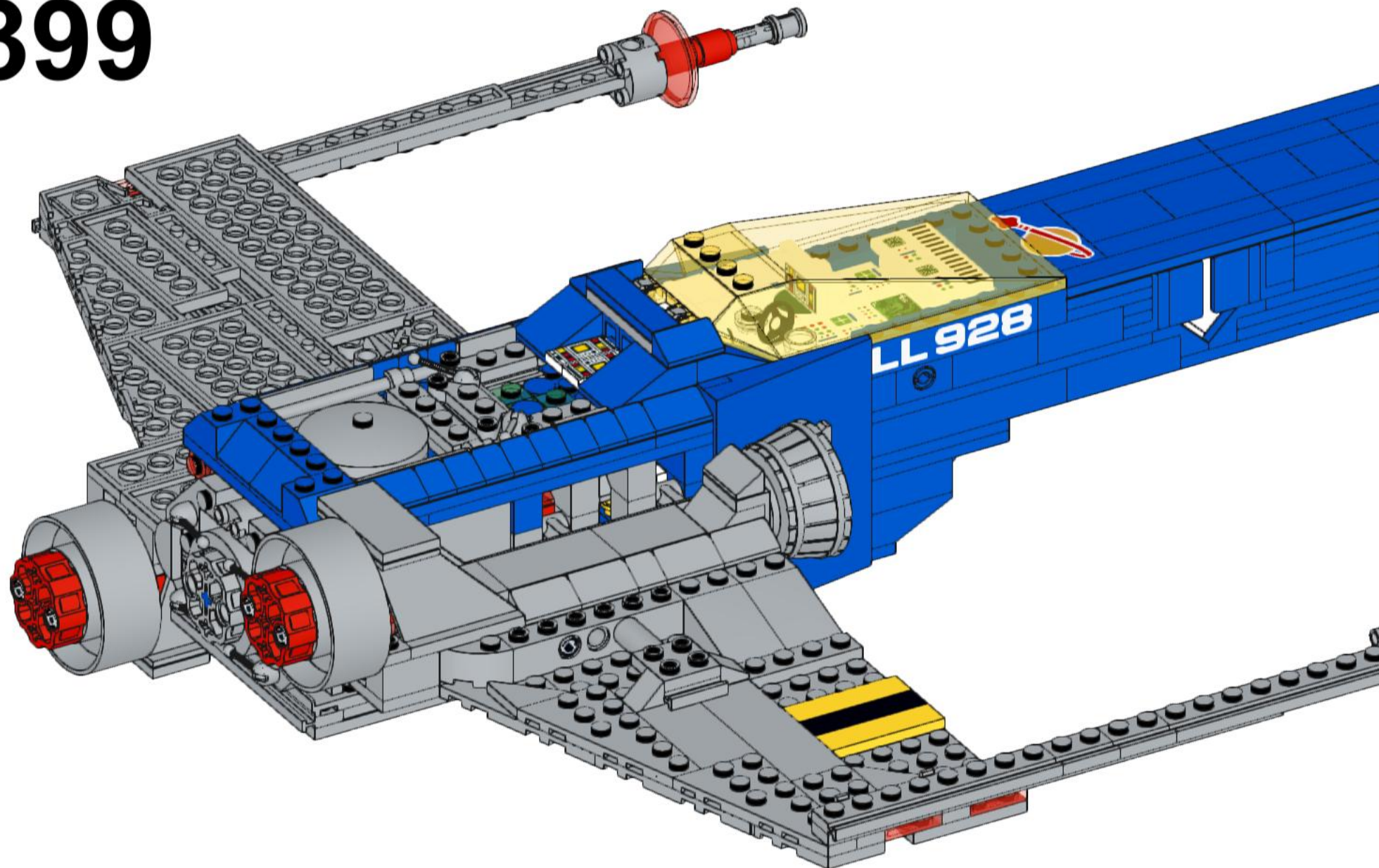

400

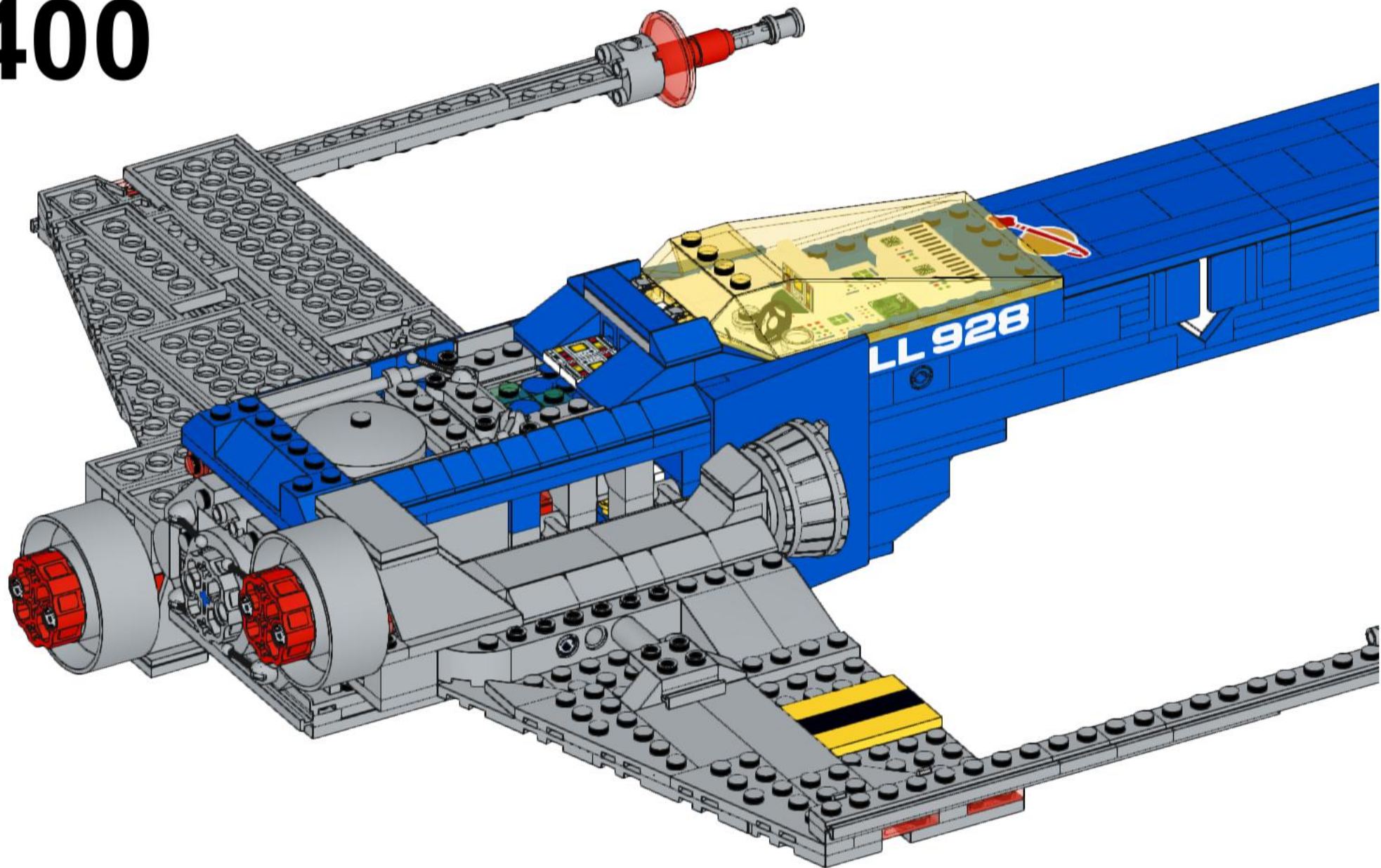

401

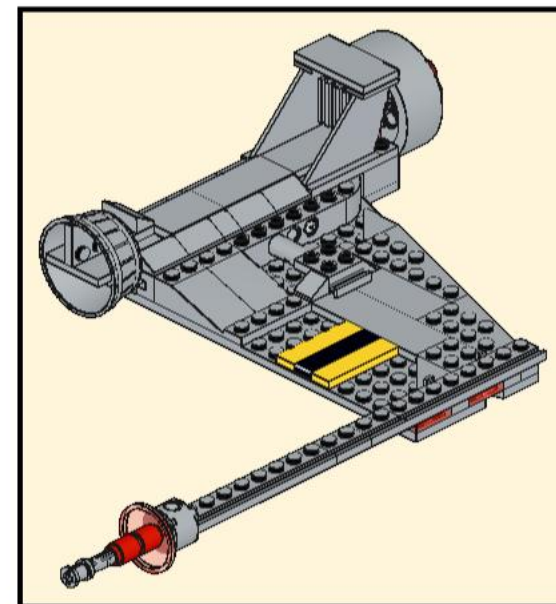
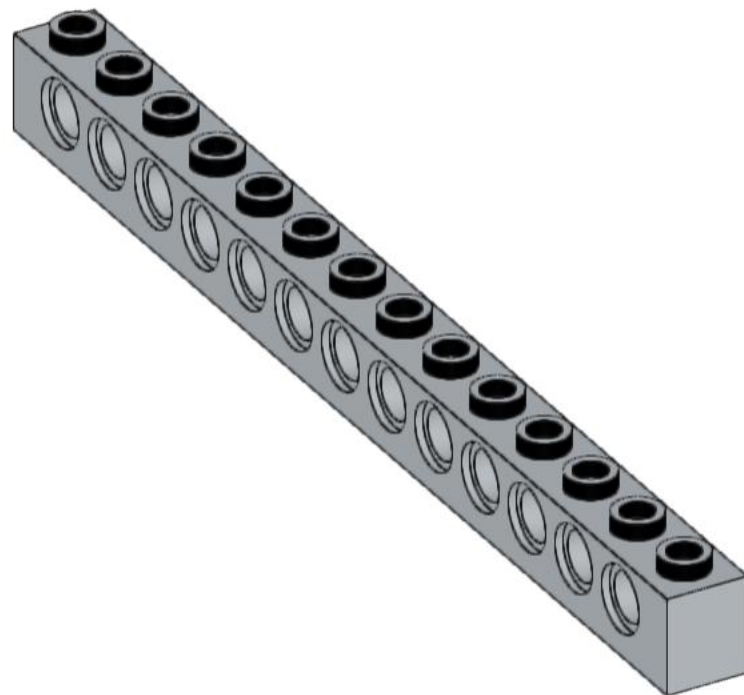
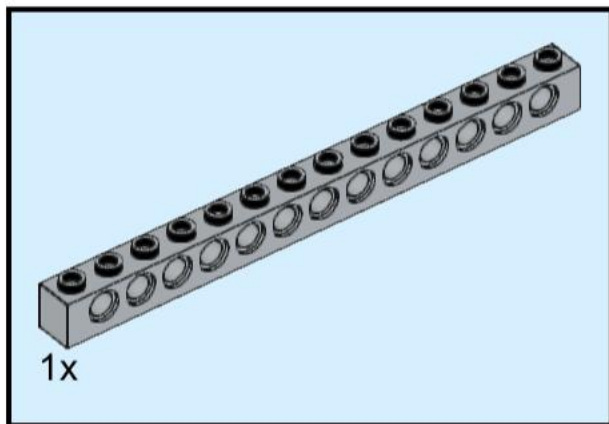

2x



402

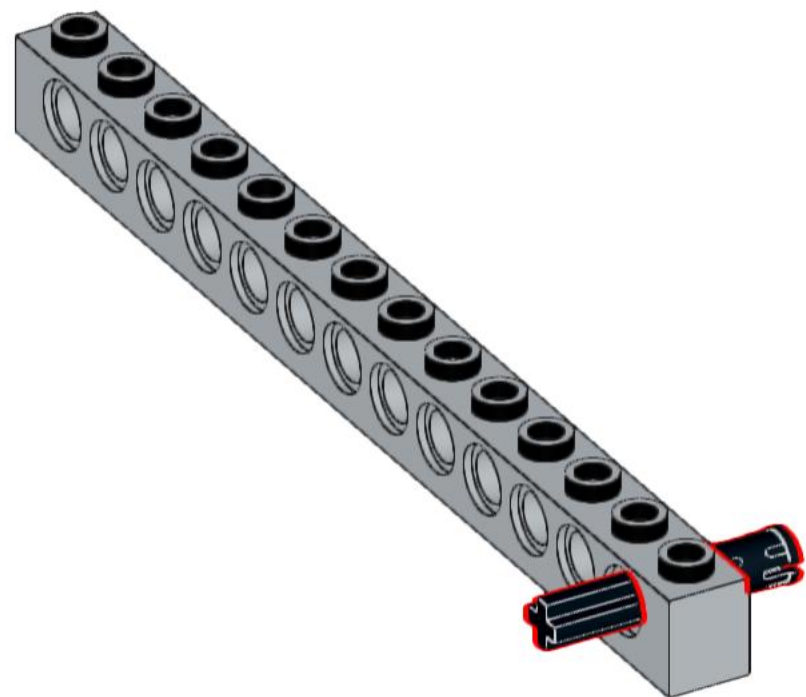
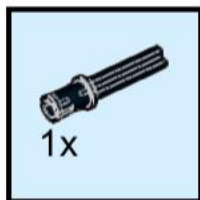

403

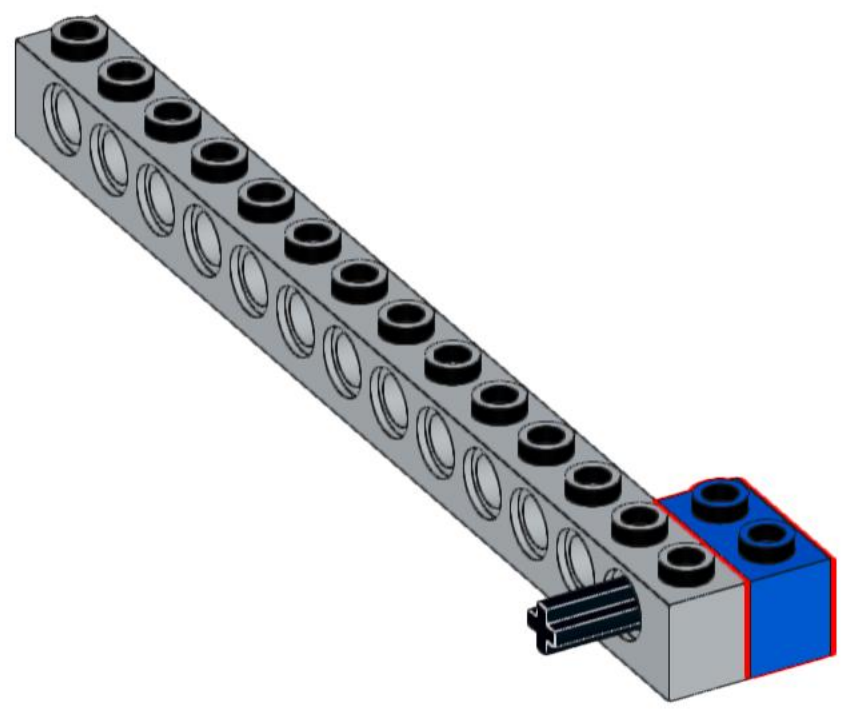
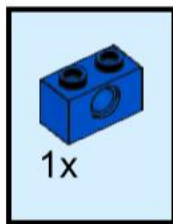

404

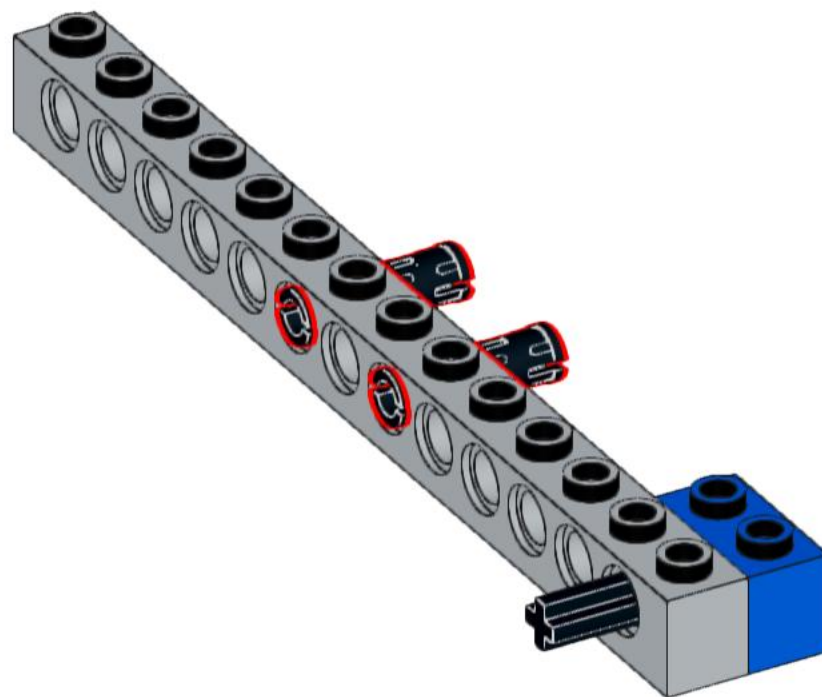

405

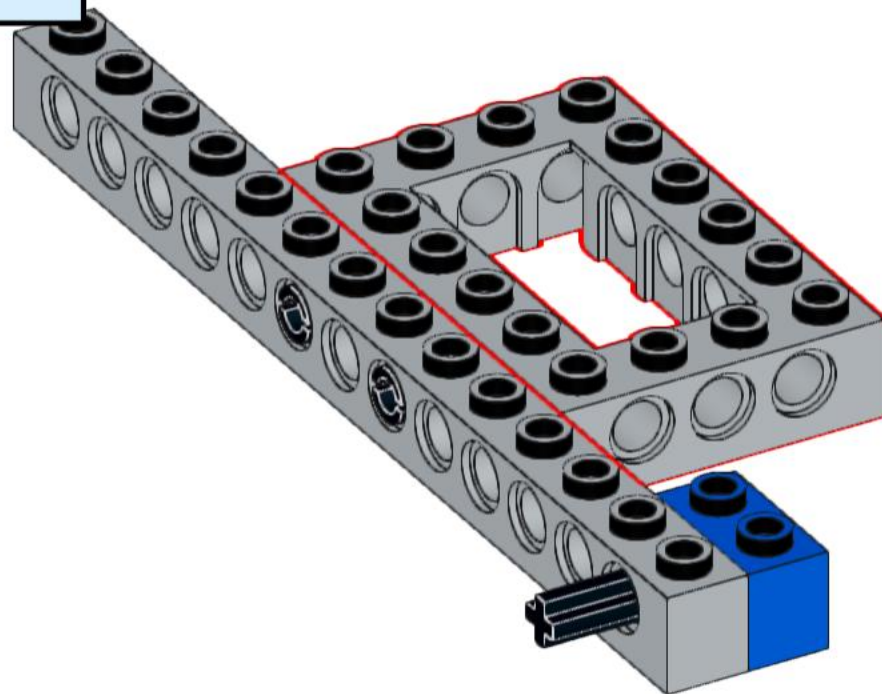
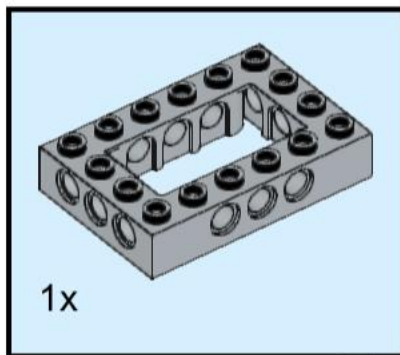

406

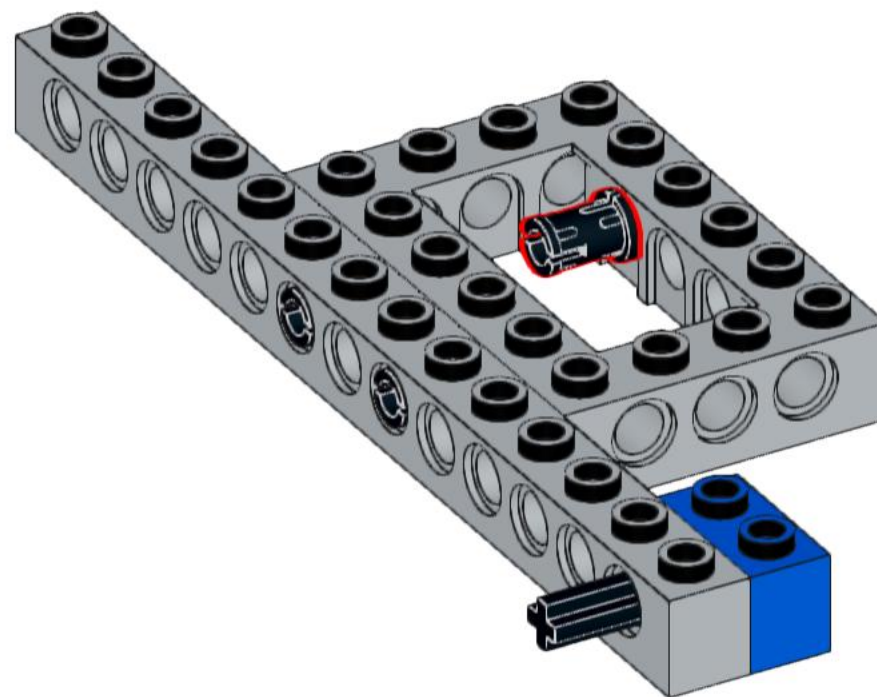

407

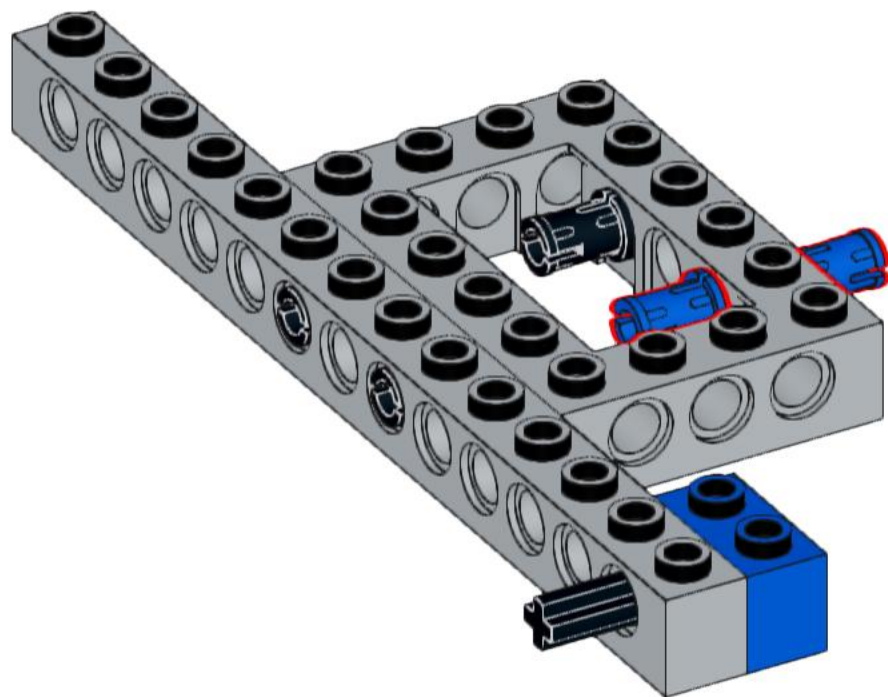
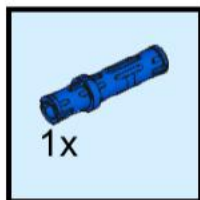

408

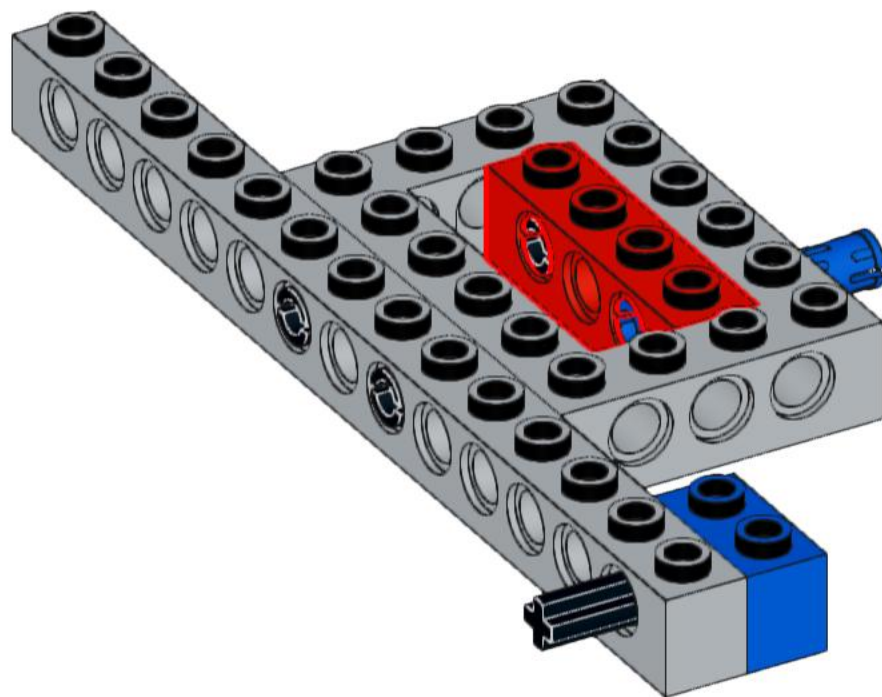
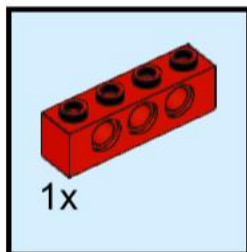

409

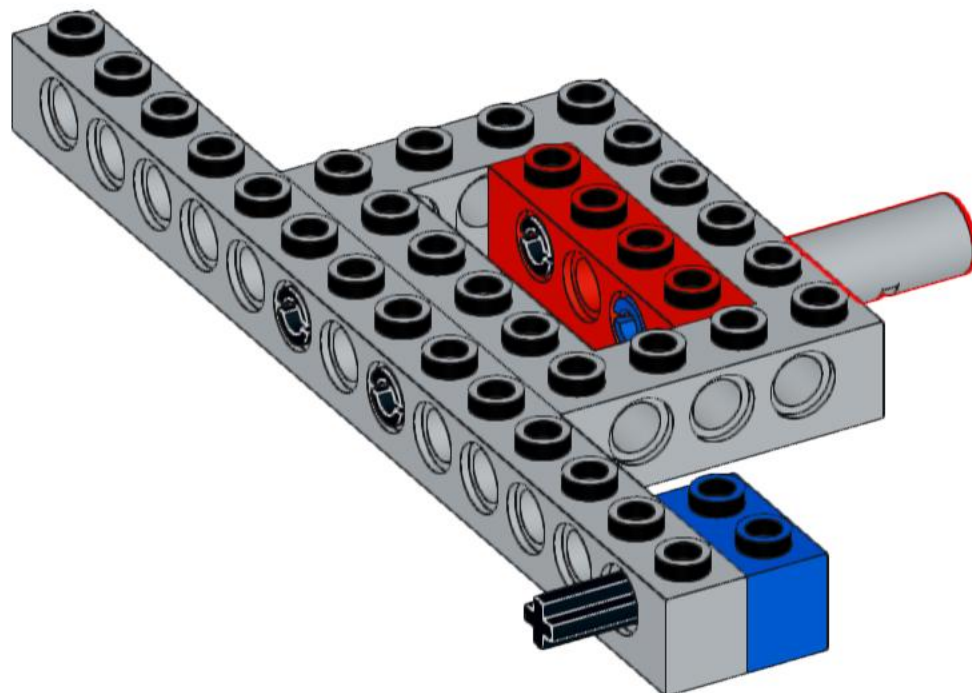
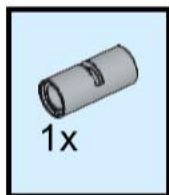

410

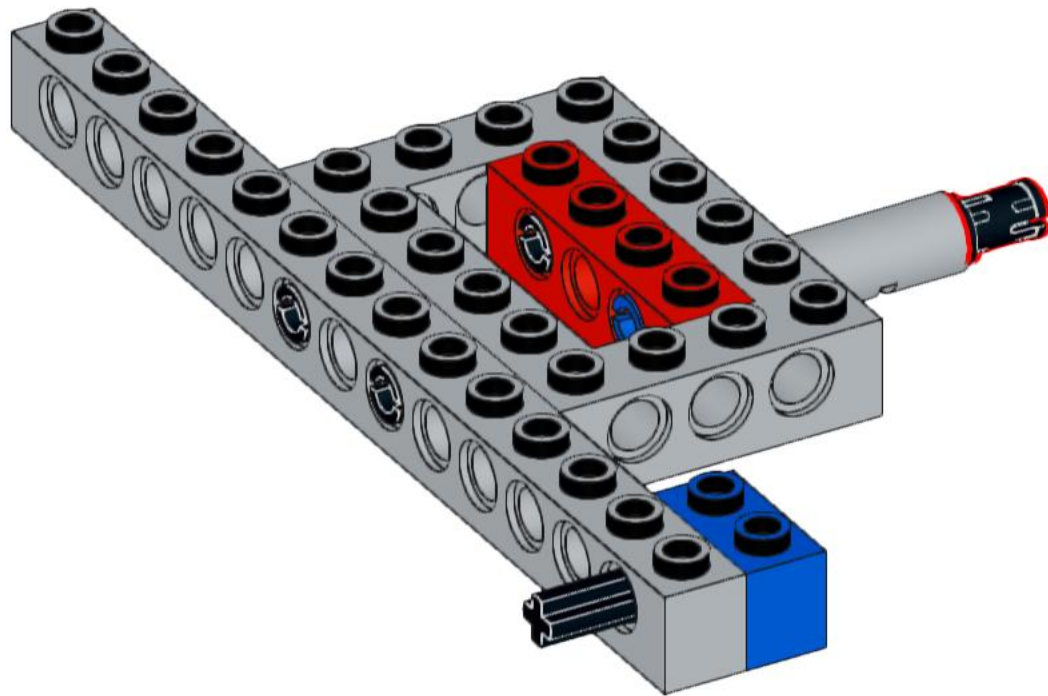
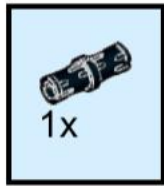

411

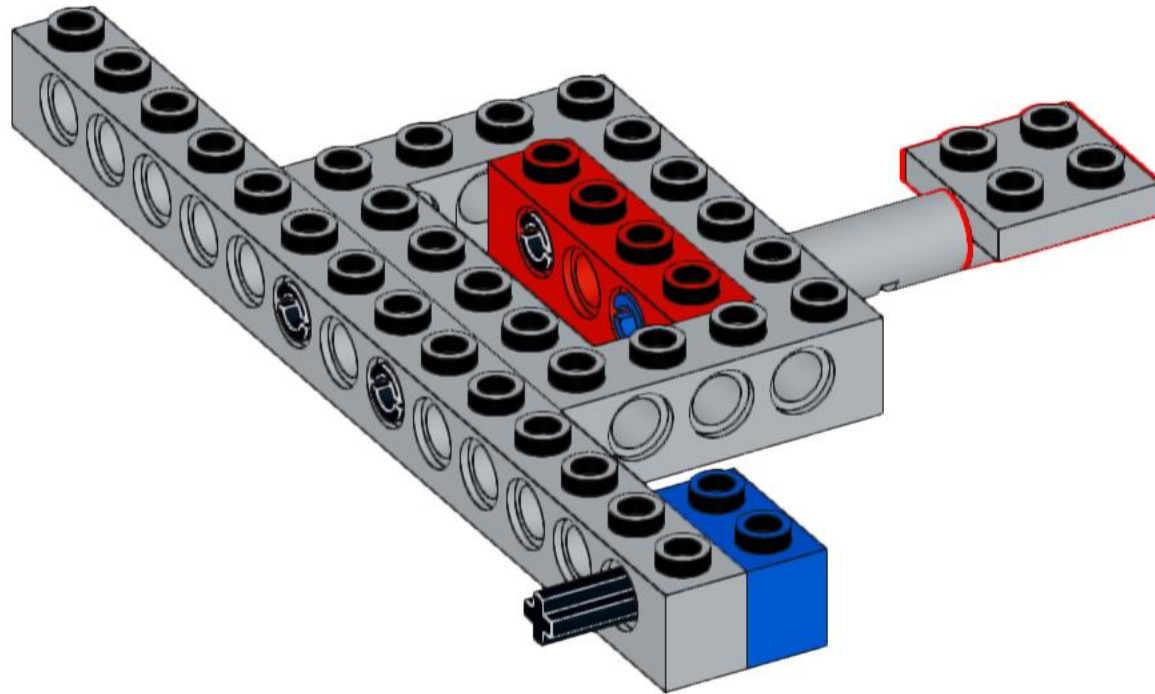
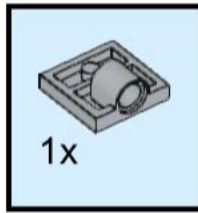

412

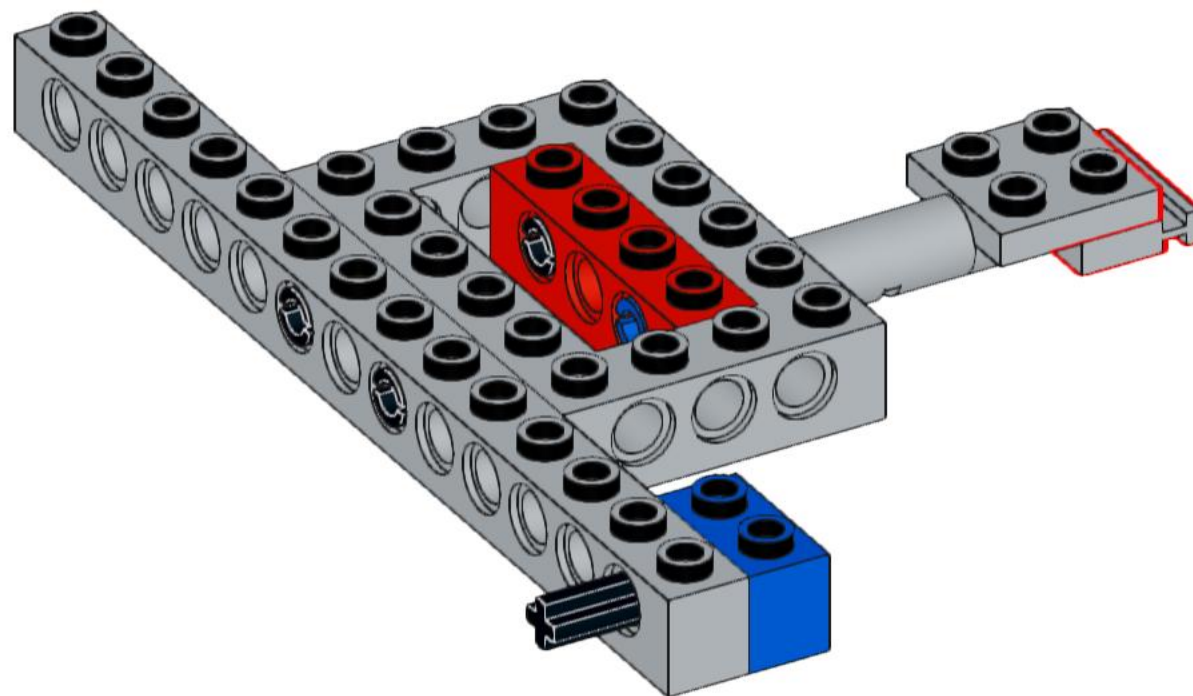
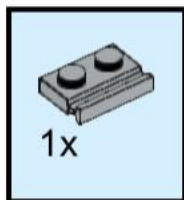

413

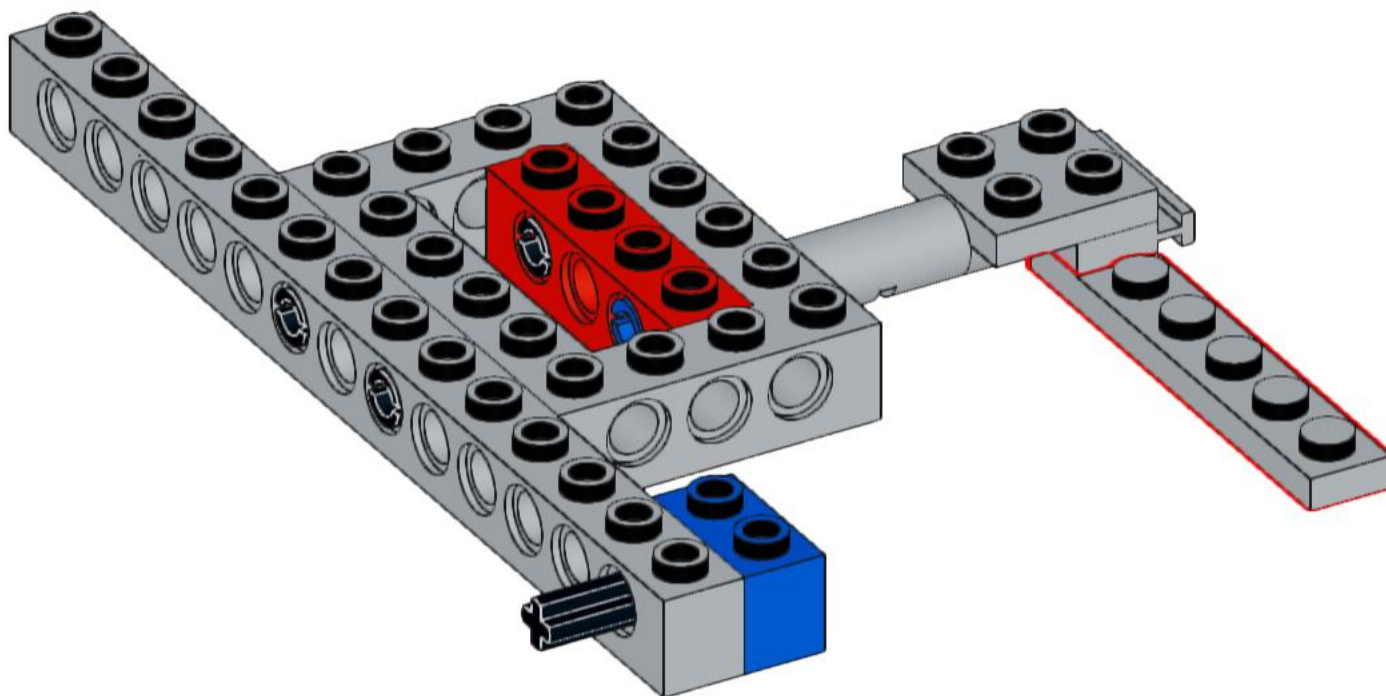
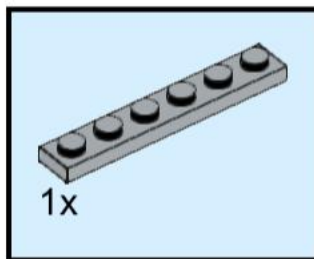

414

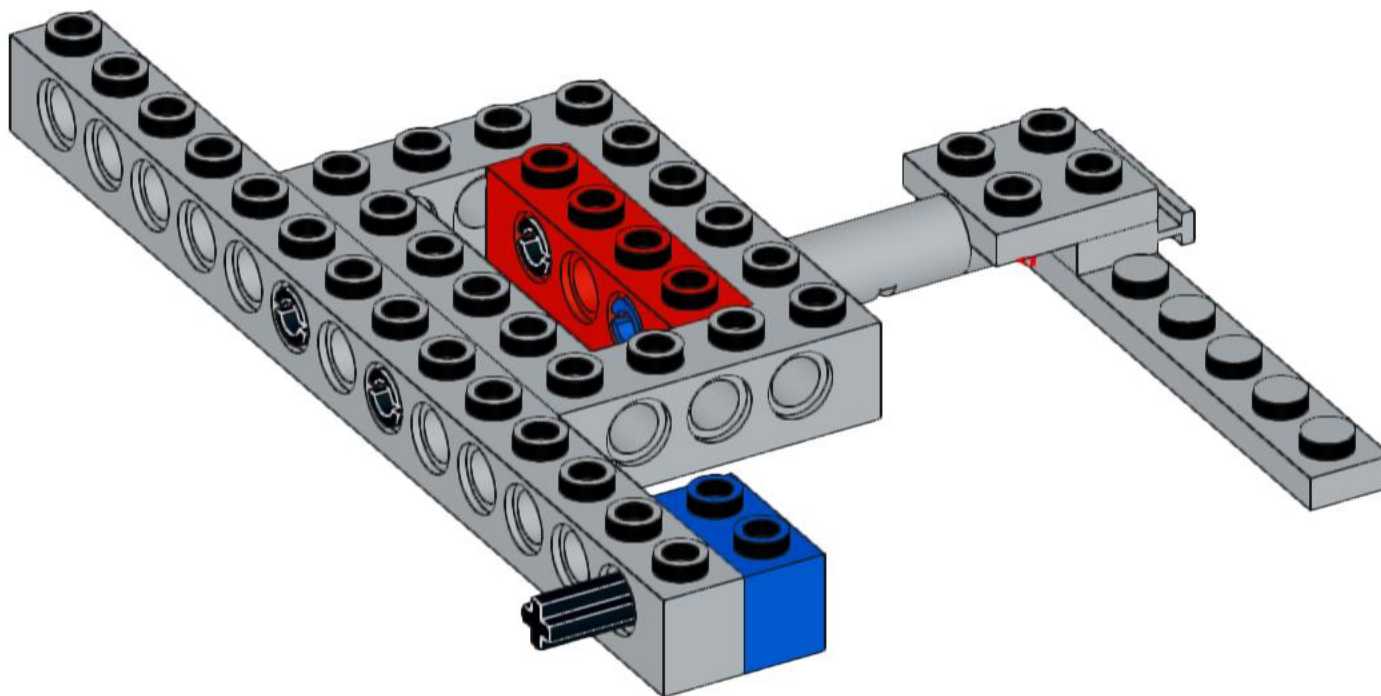
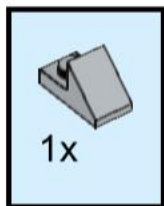

415

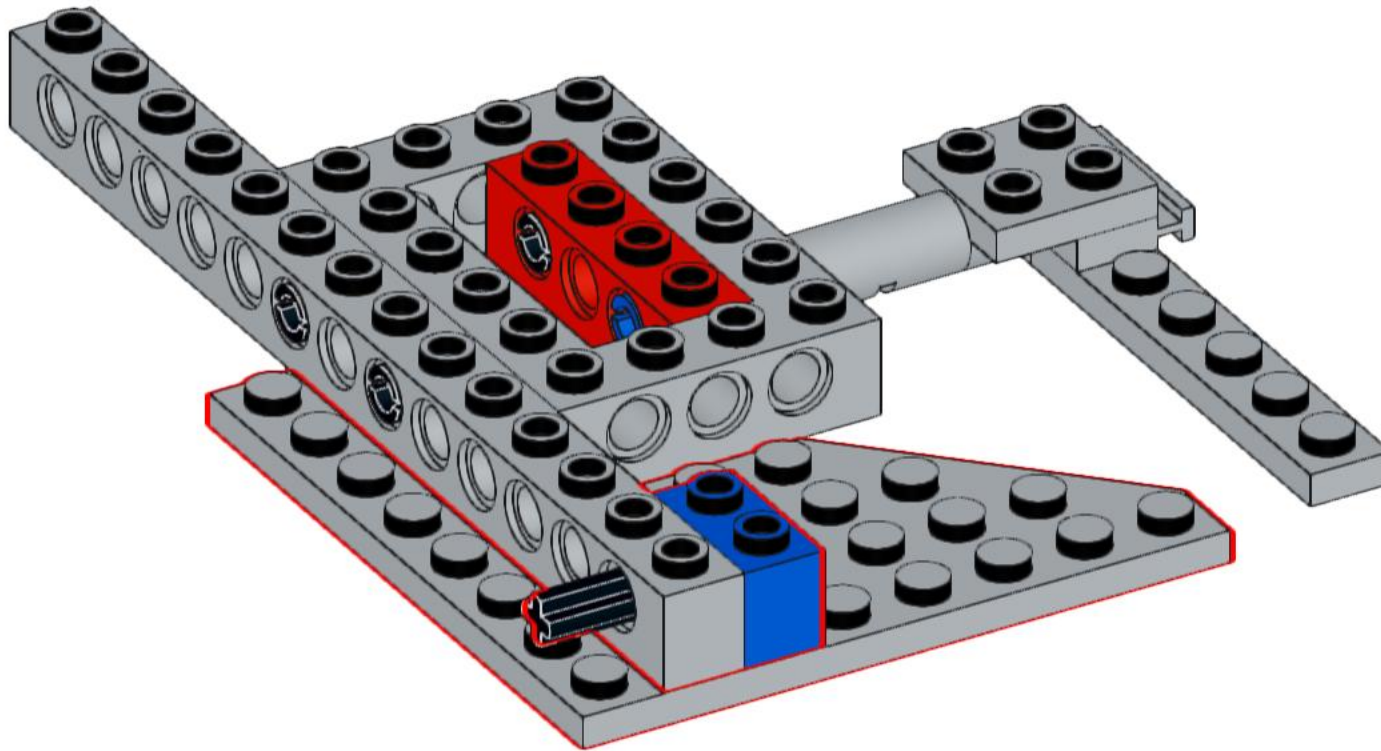
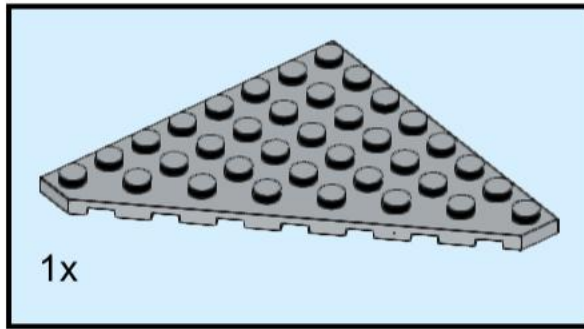

416

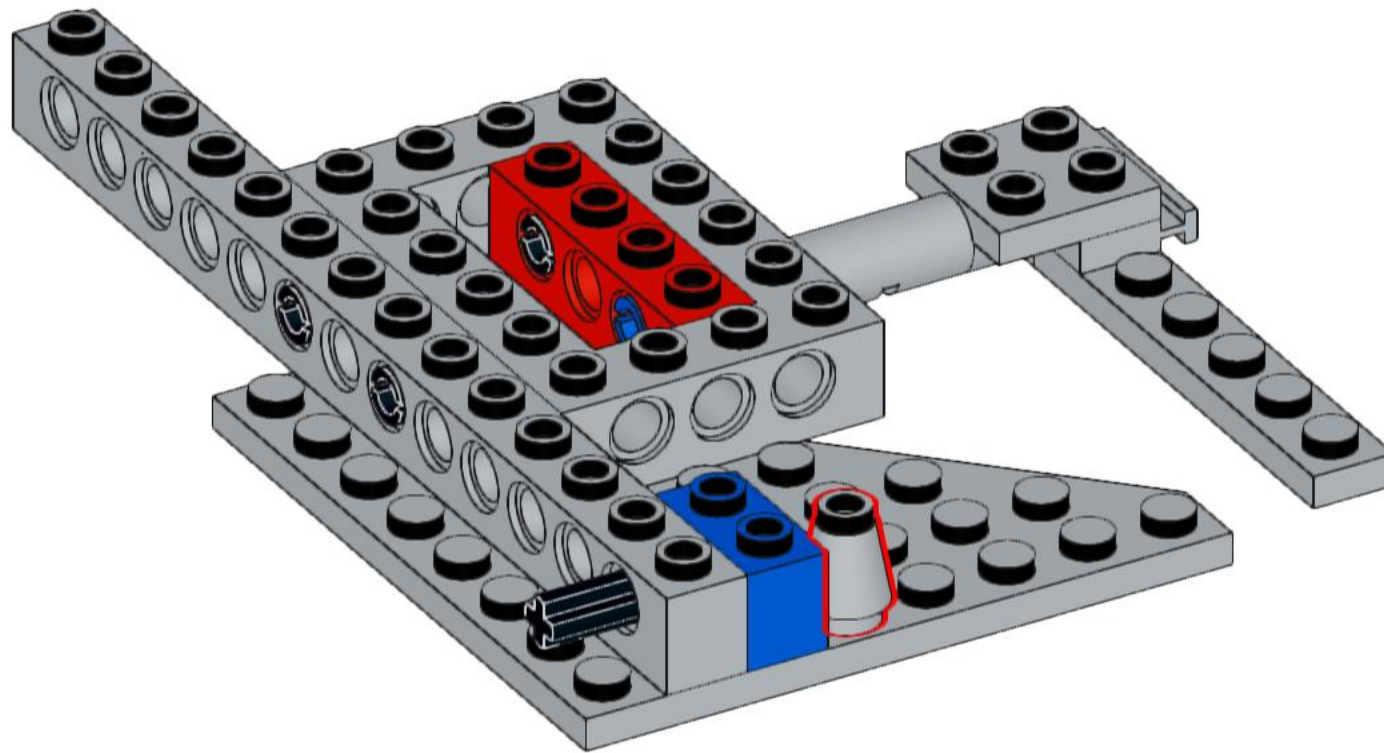
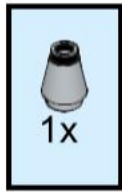

417

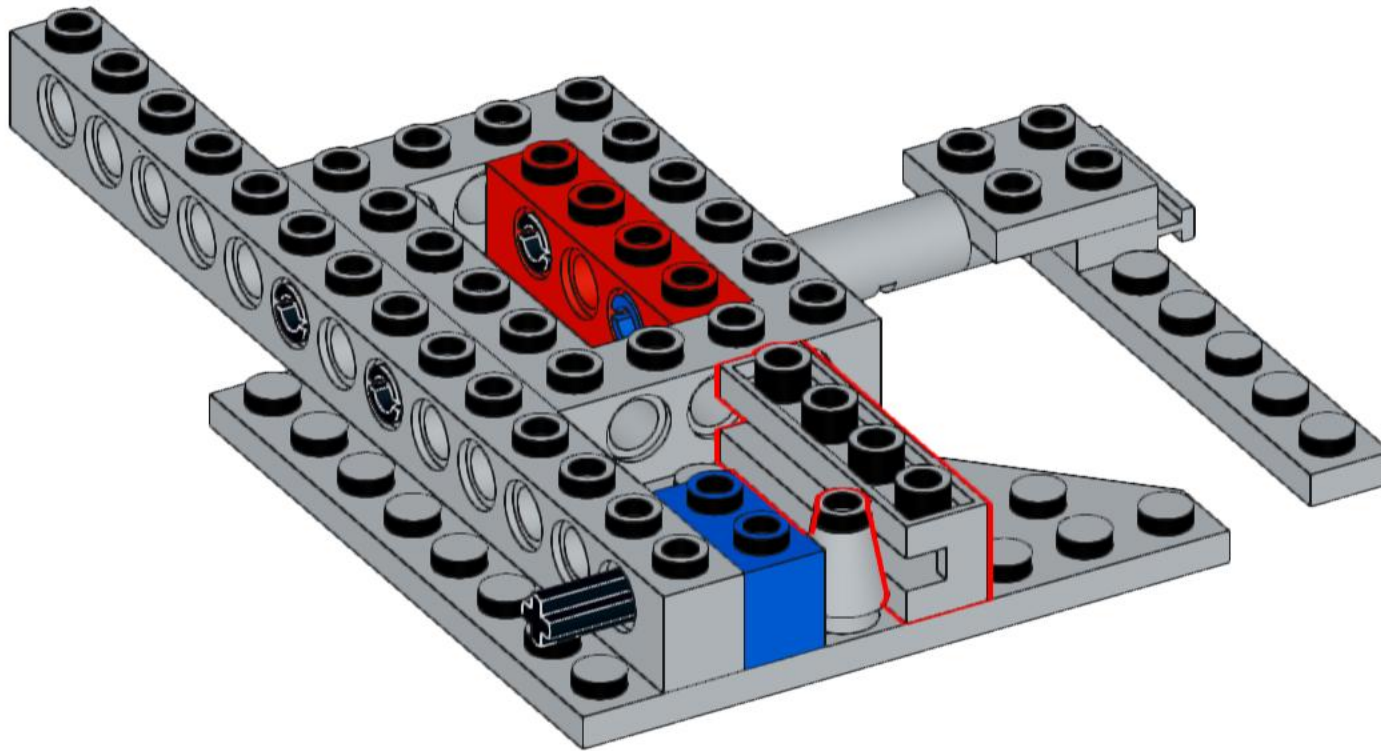
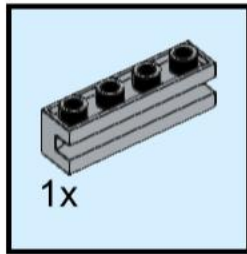

418

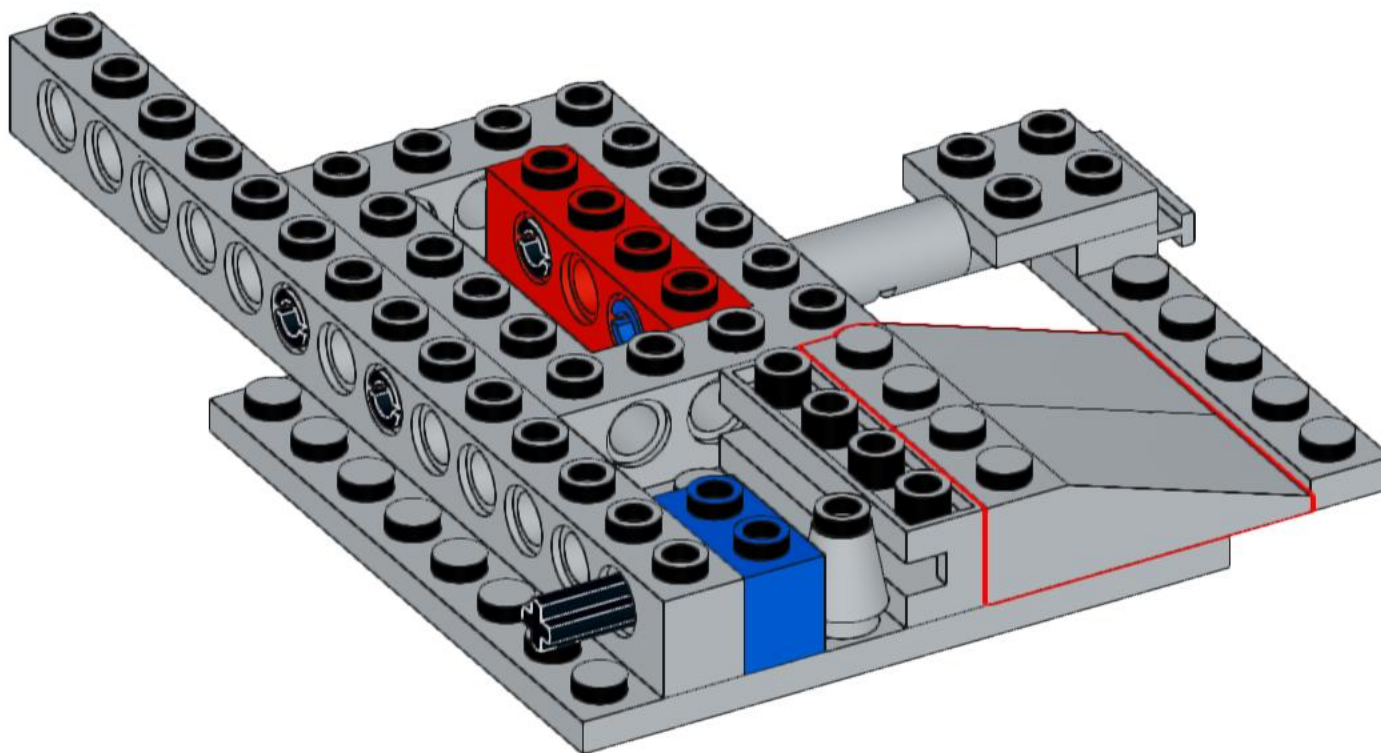
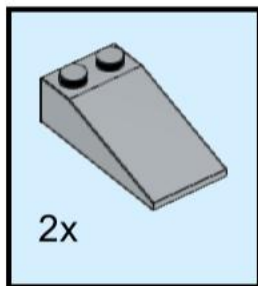

419

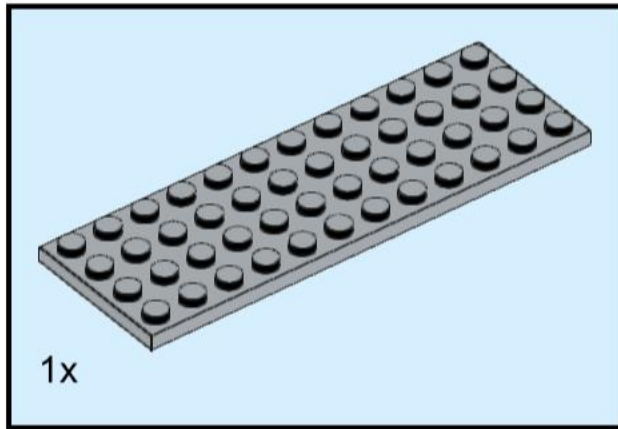

OR

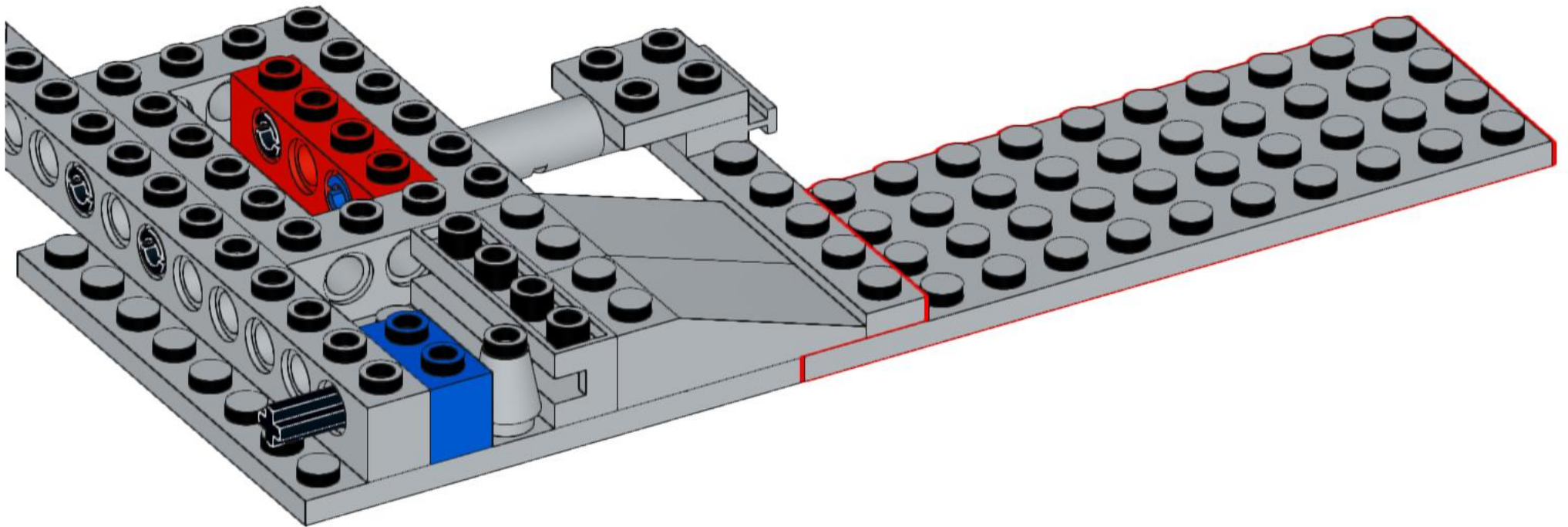
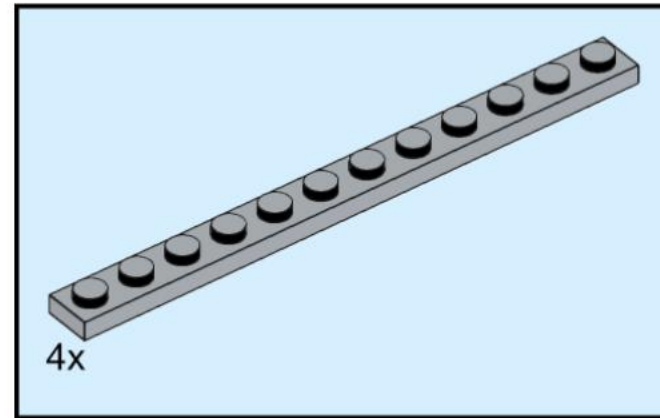

On this step your two wings will differ very slightly. One will use the single plate and the other will use the four smaller plates.

This is just due to the limited pieces in the Galaxy Explorer donor set. It is presented this way in the instructions so you can still build both of these wings at the same time.

420

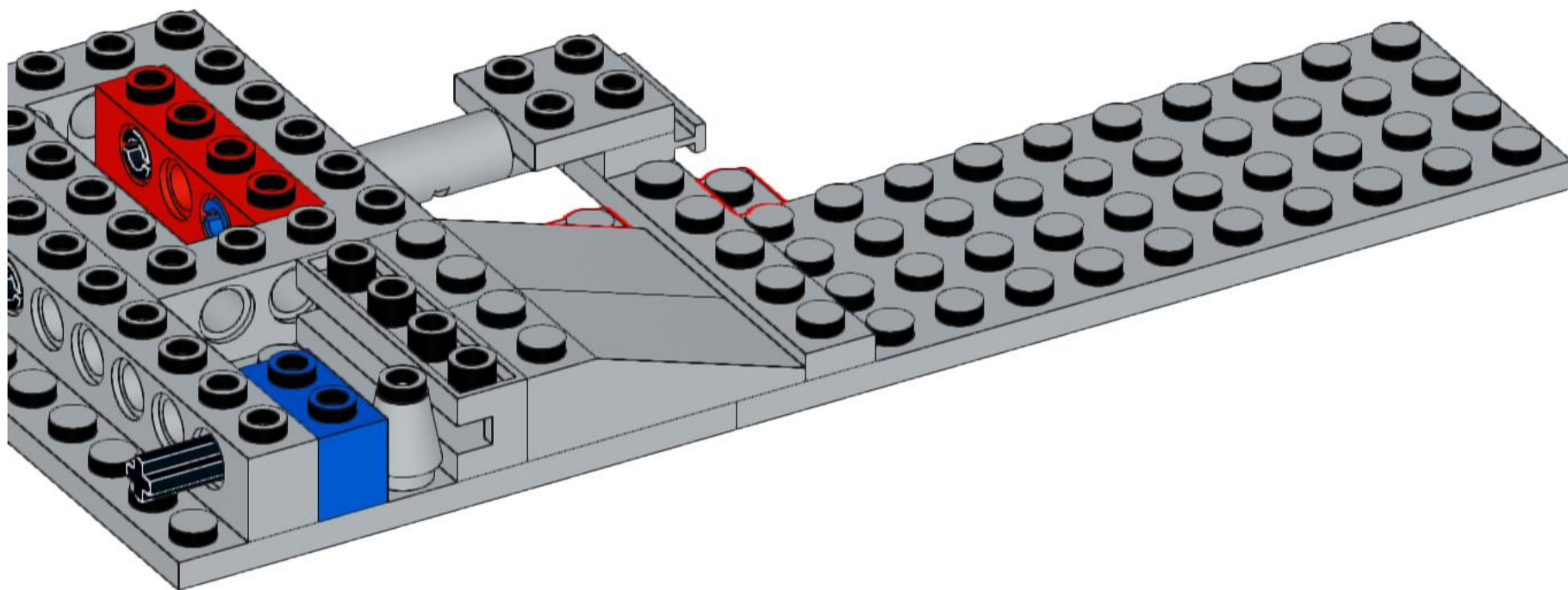
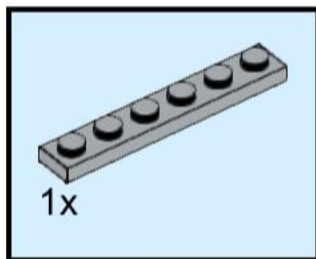

421

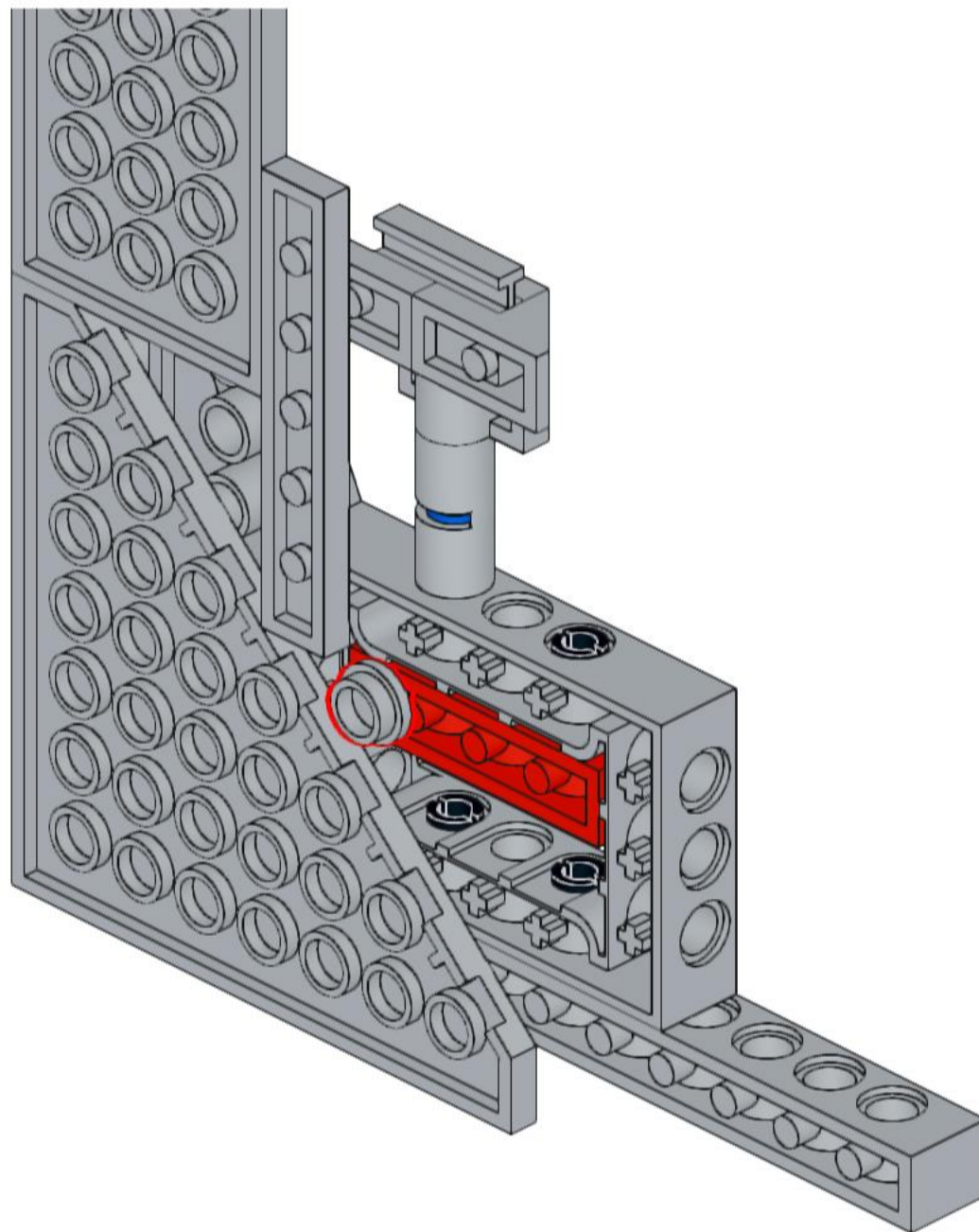

422

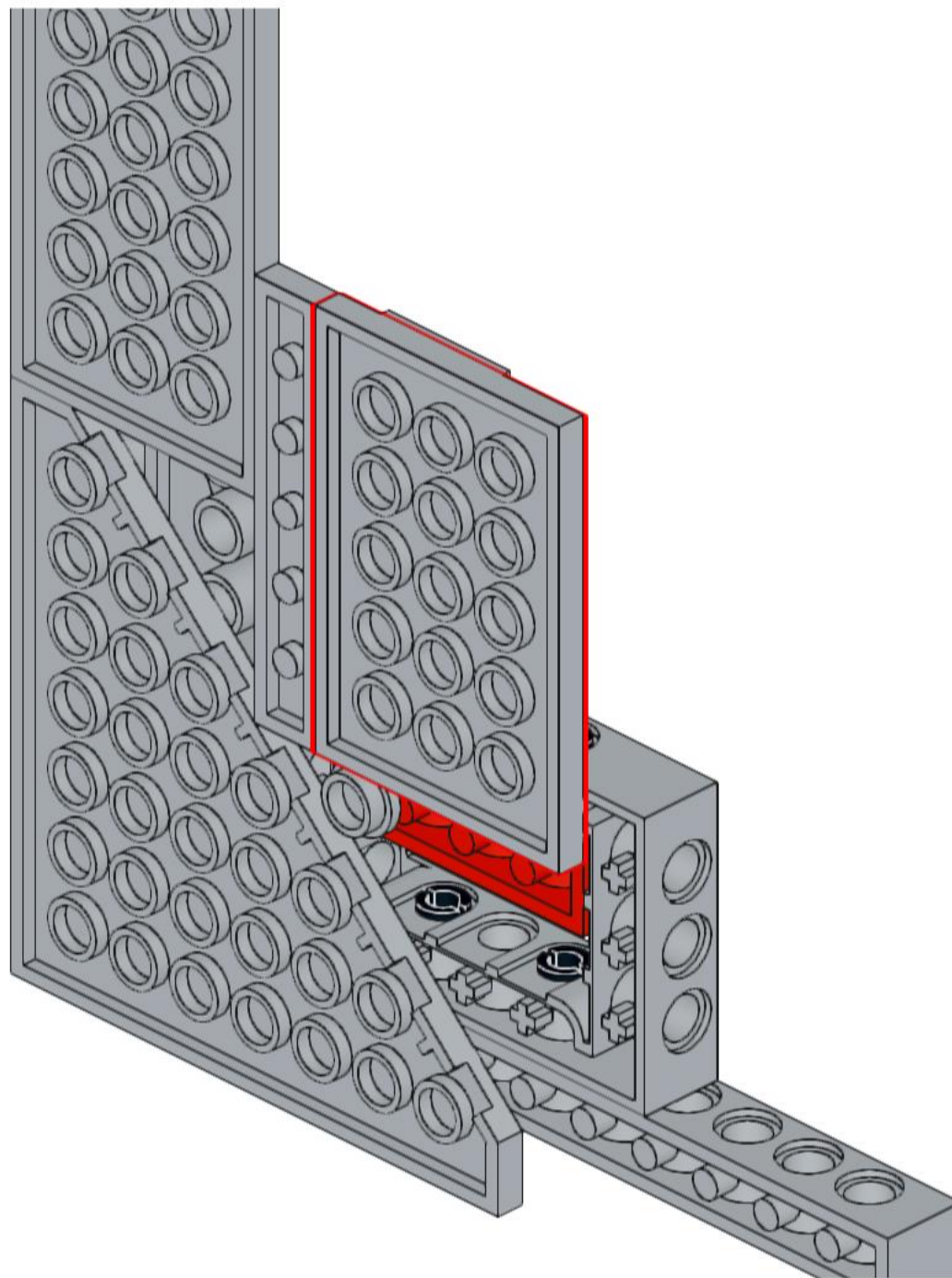
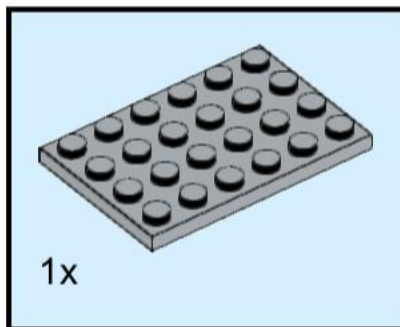

423

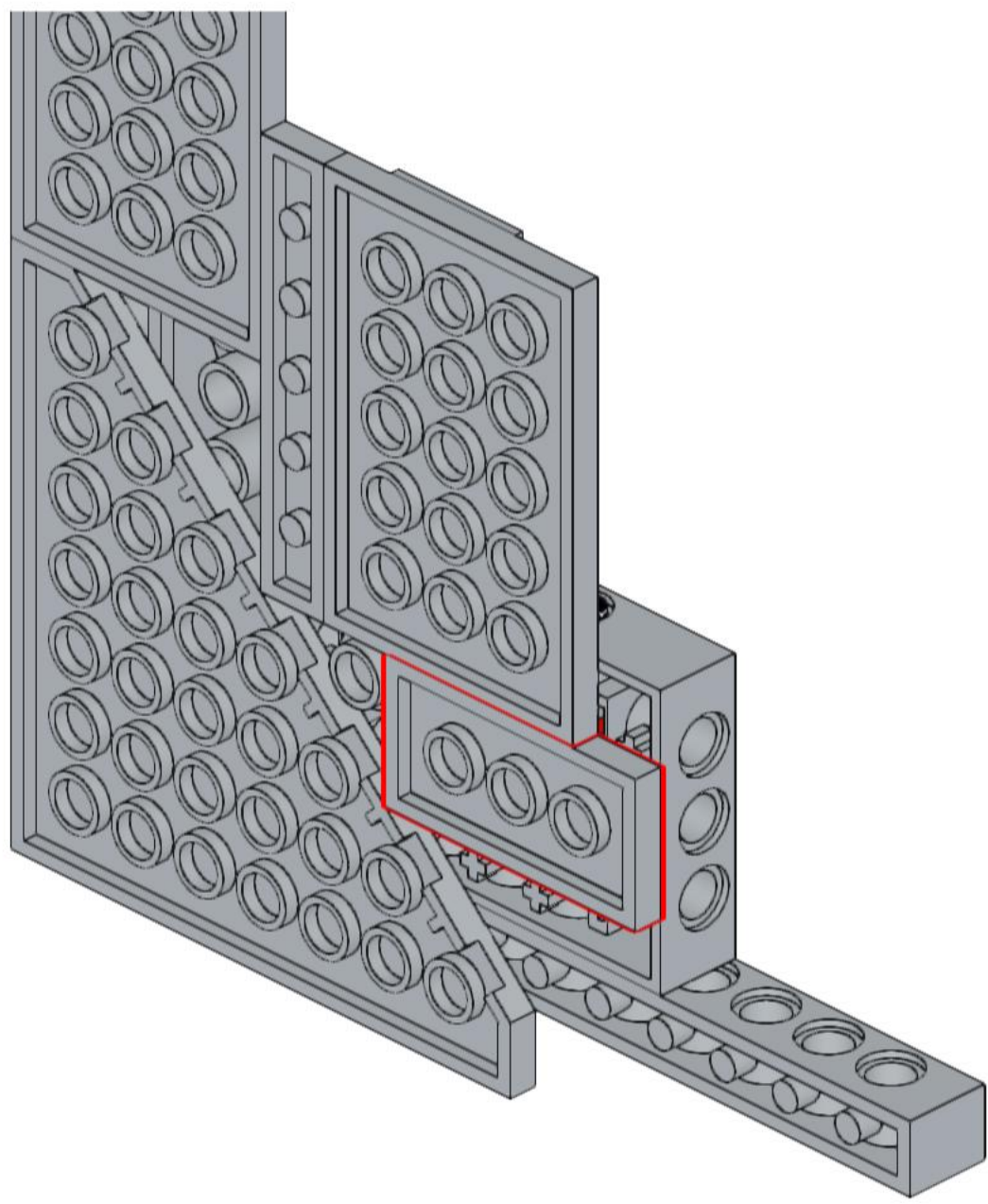
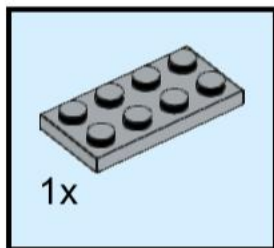

424

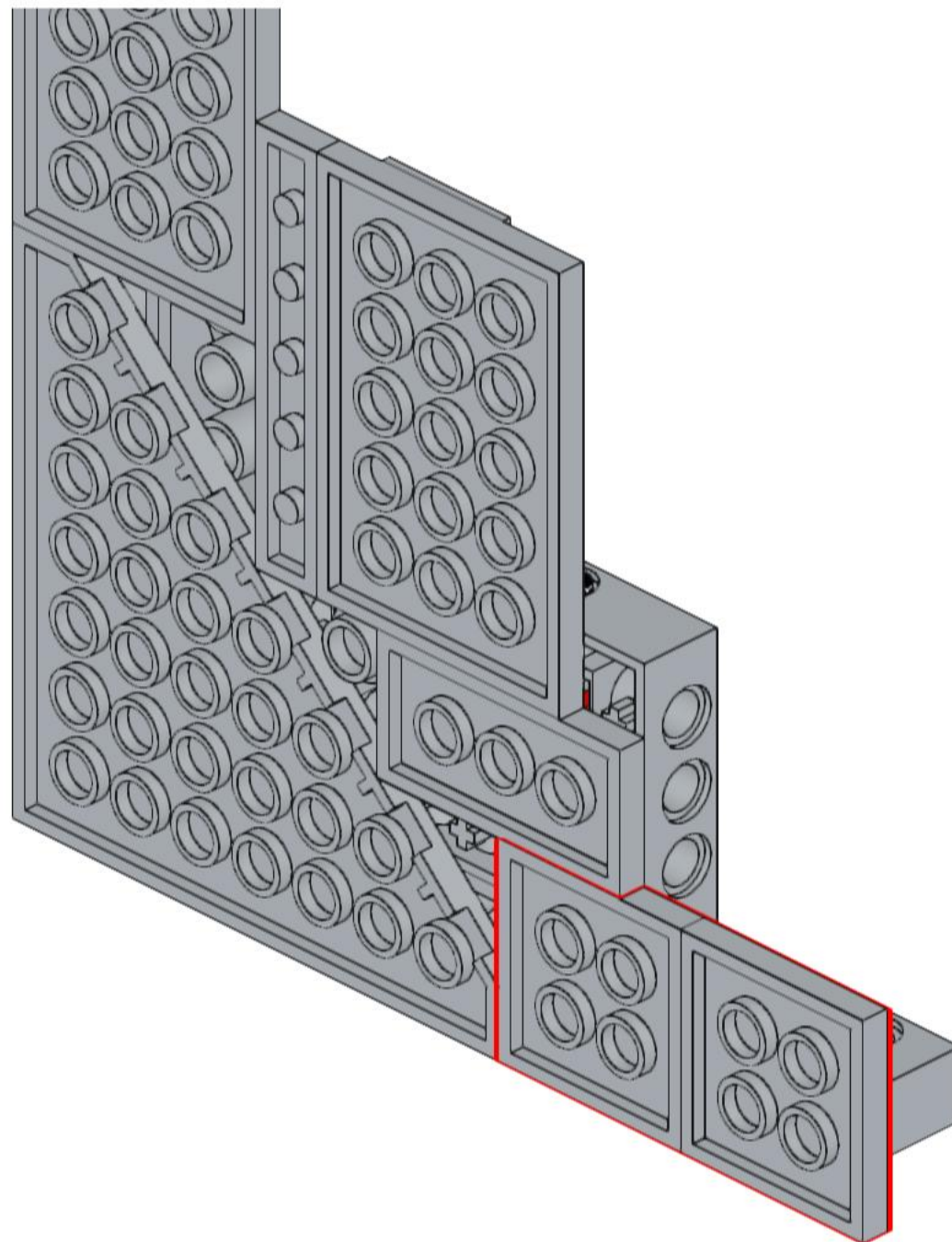
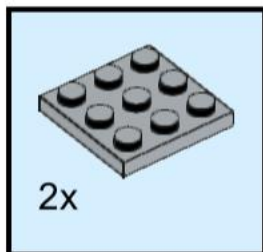

425

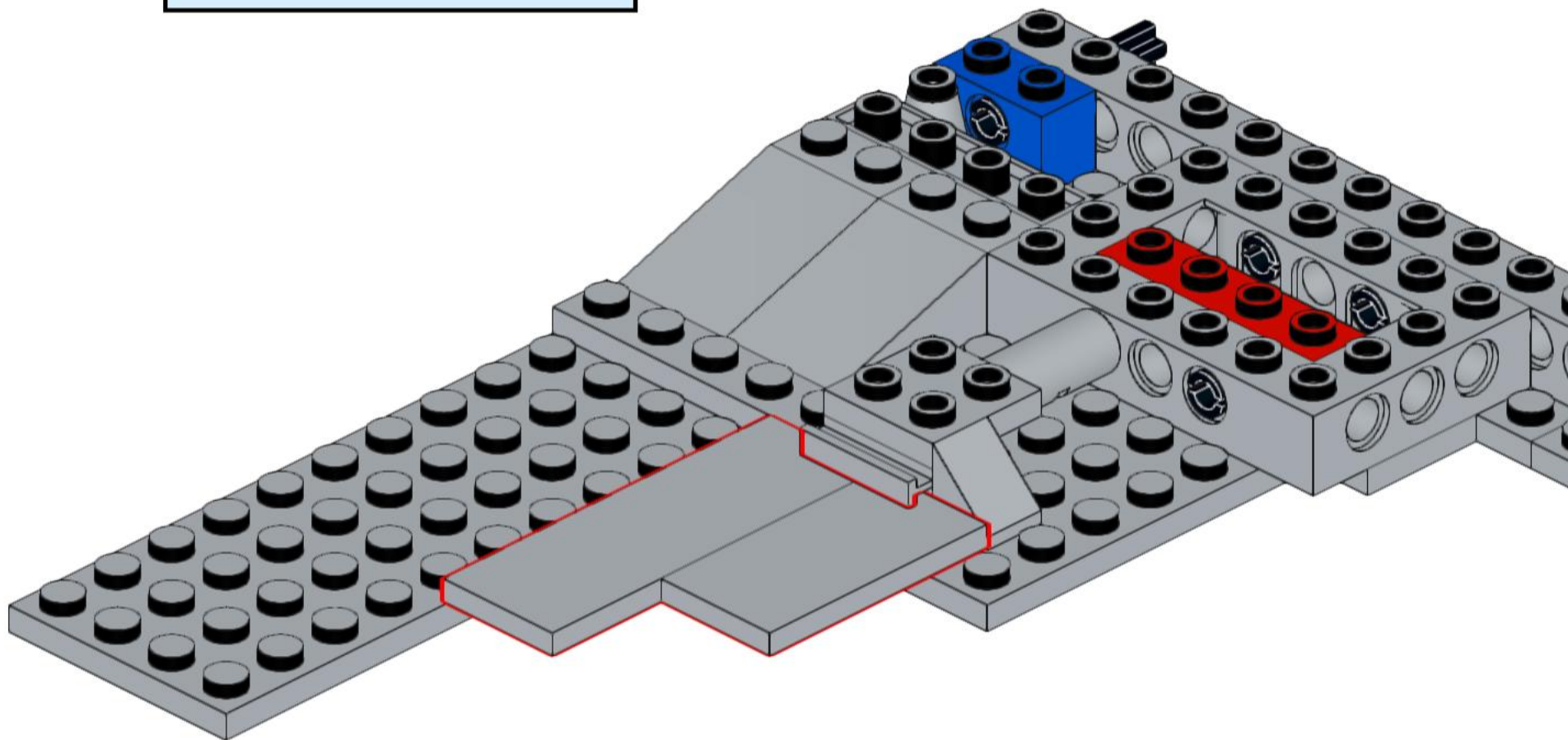
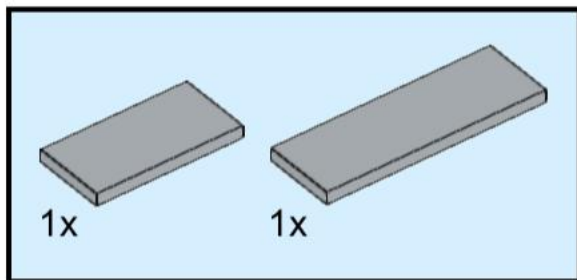

426

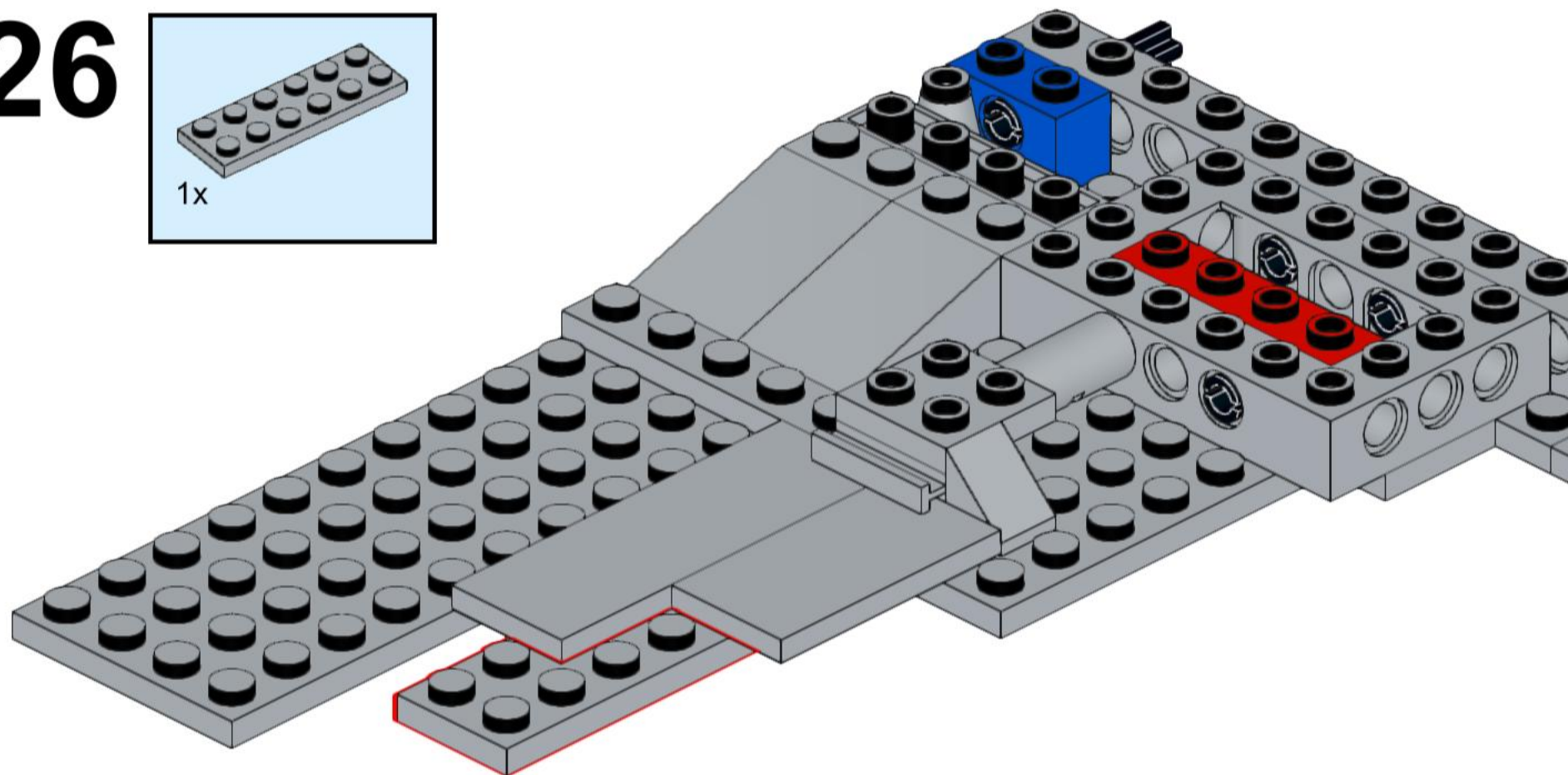
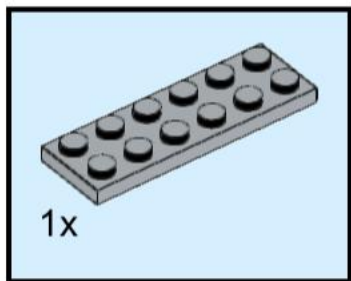

427

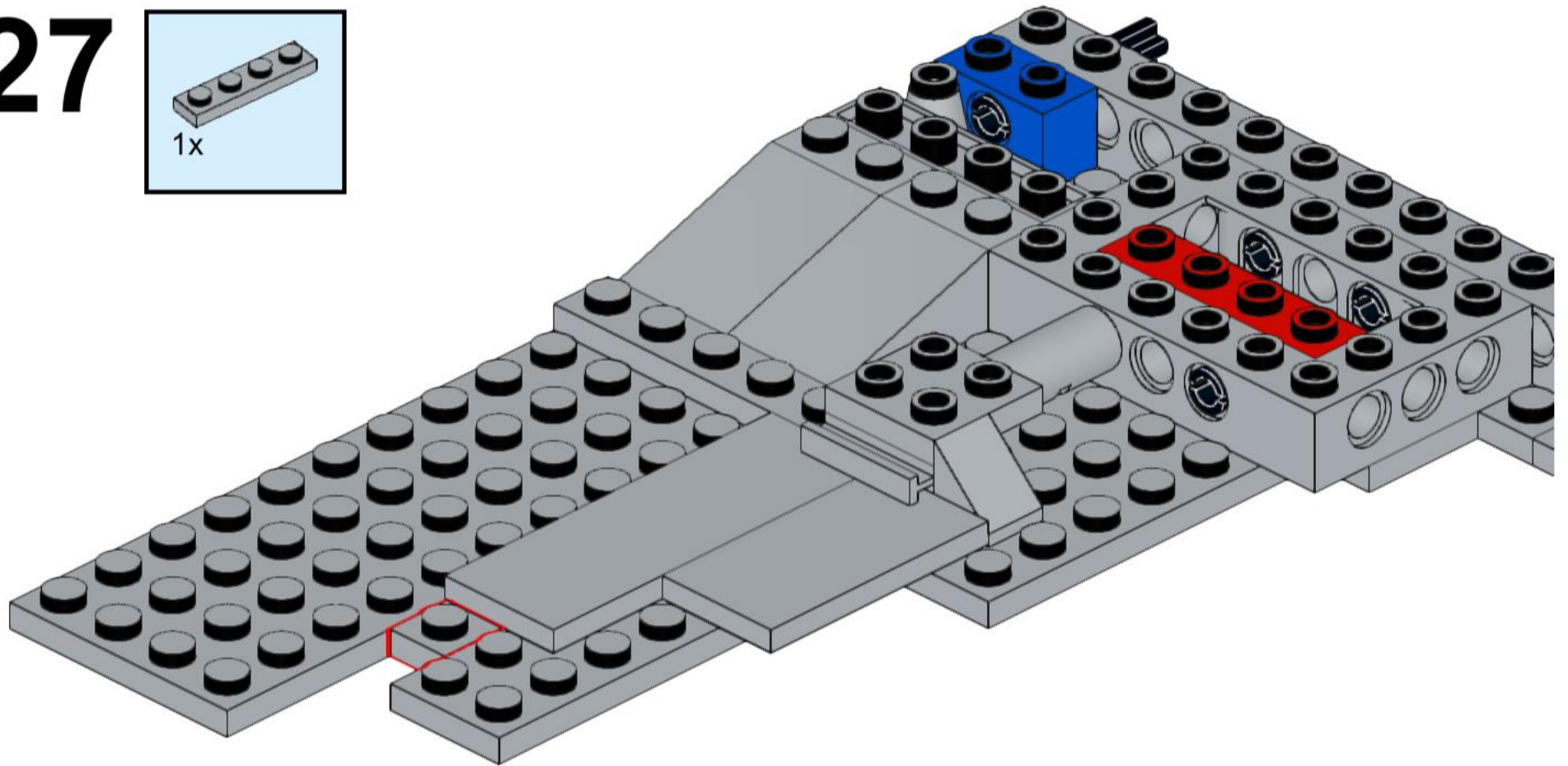
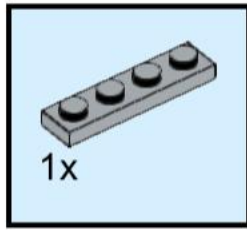

428

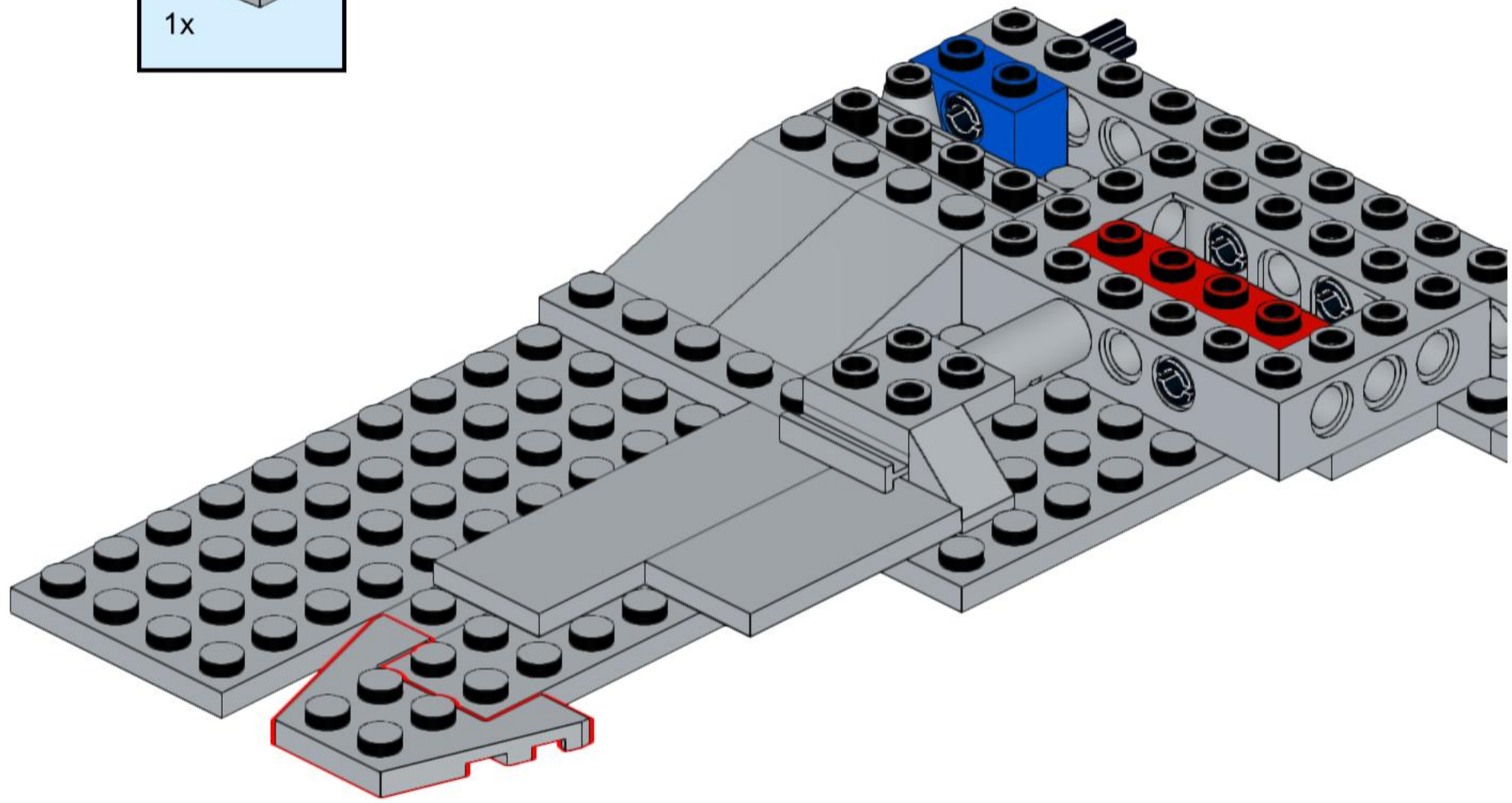
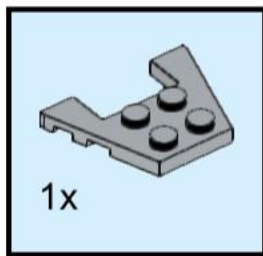

429

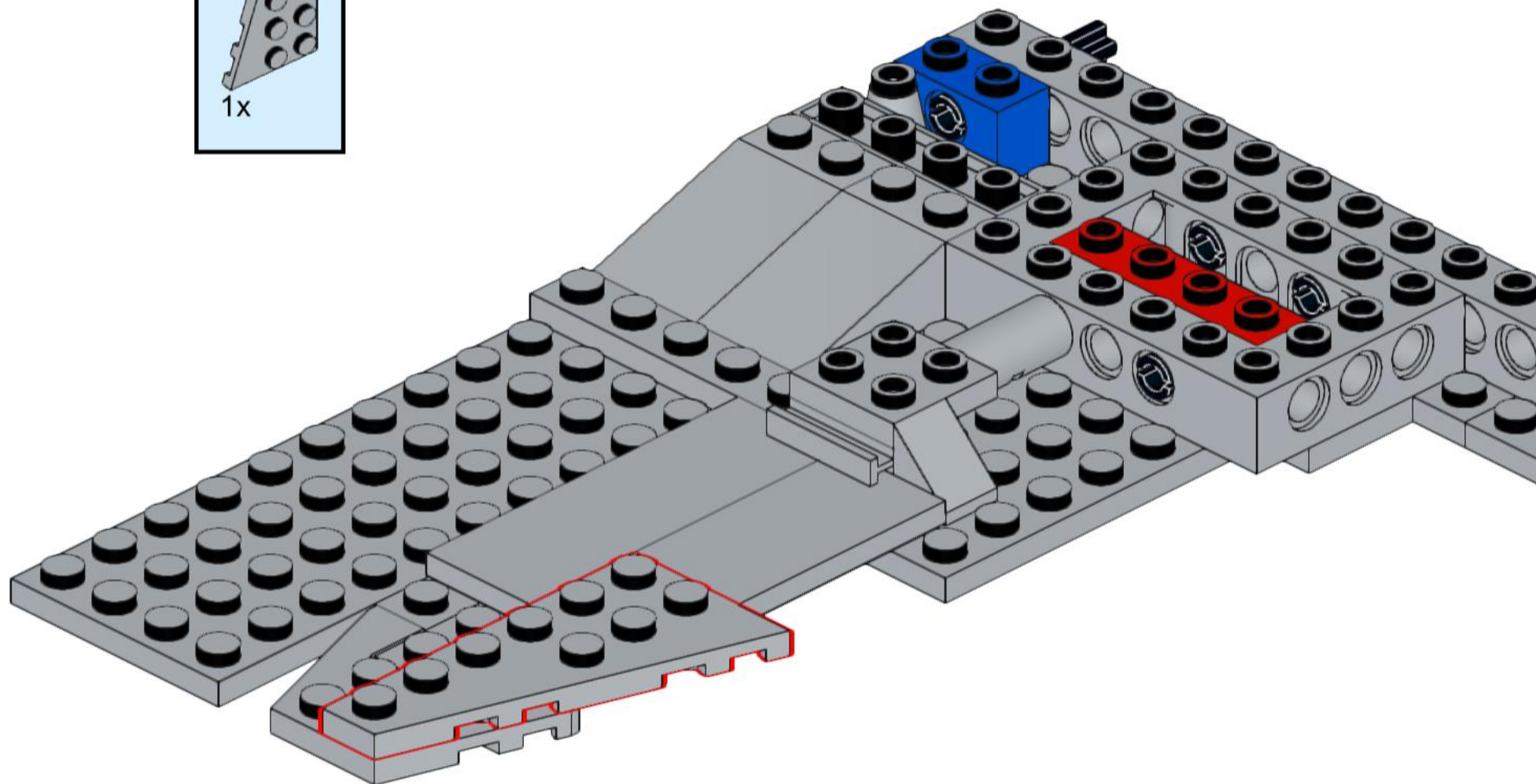
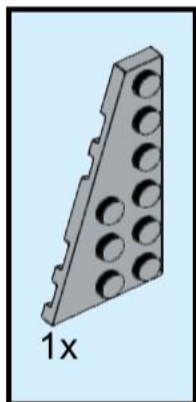

430

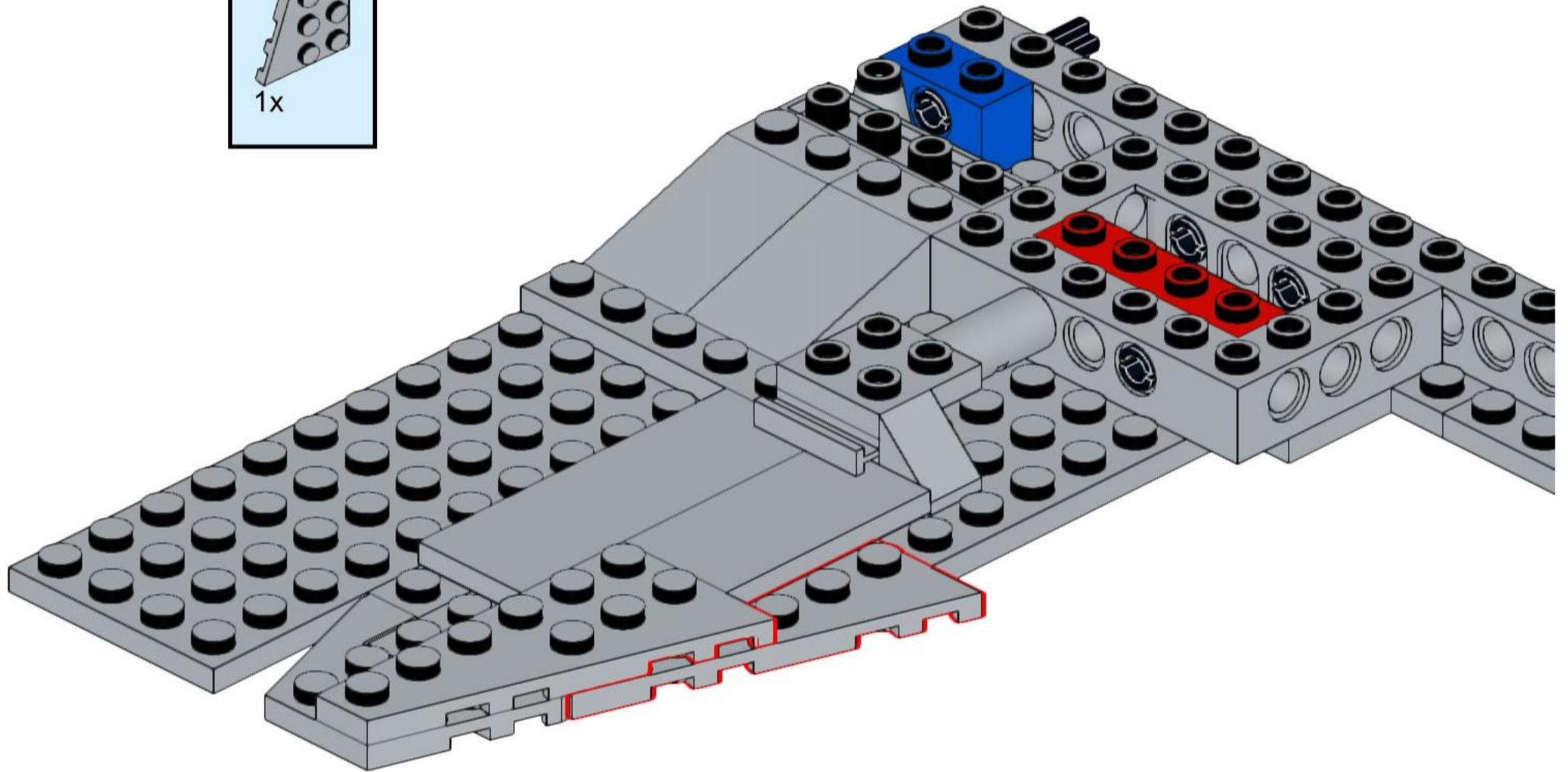
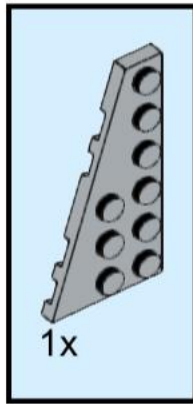

431

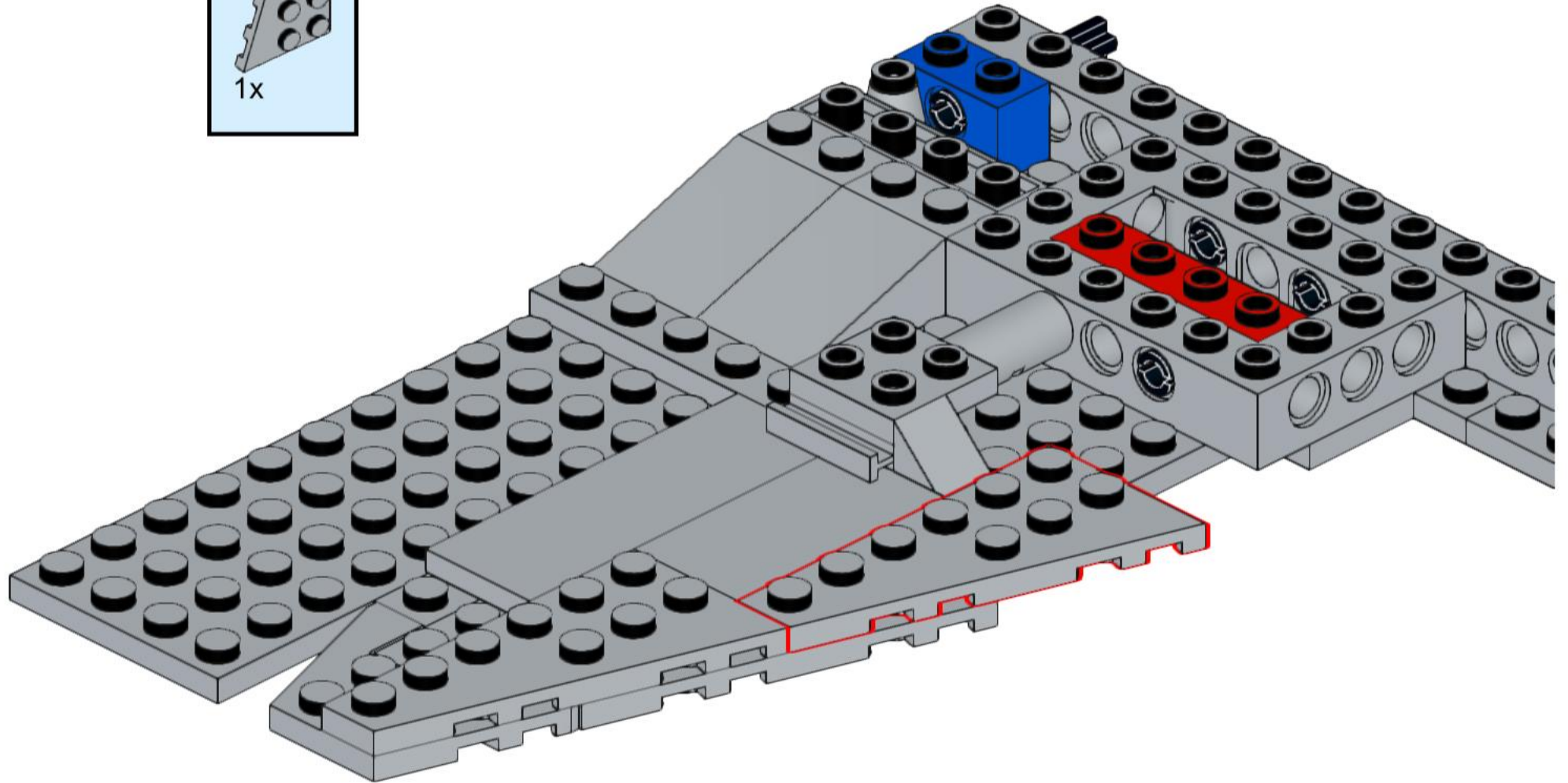
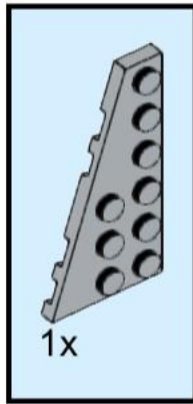

432

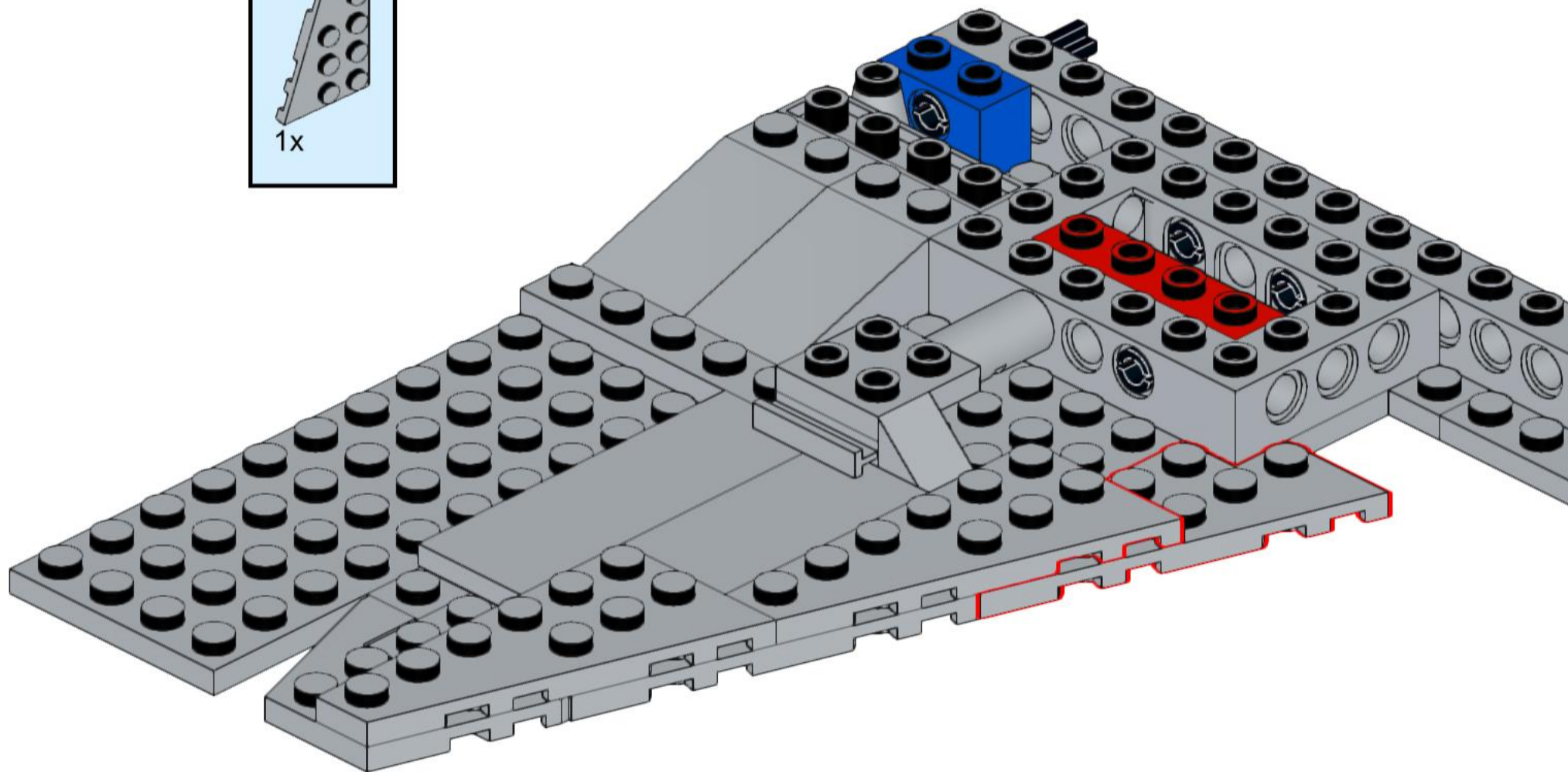
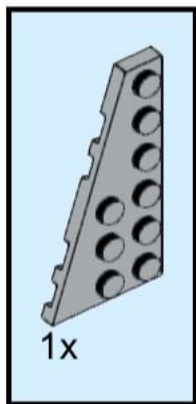

433

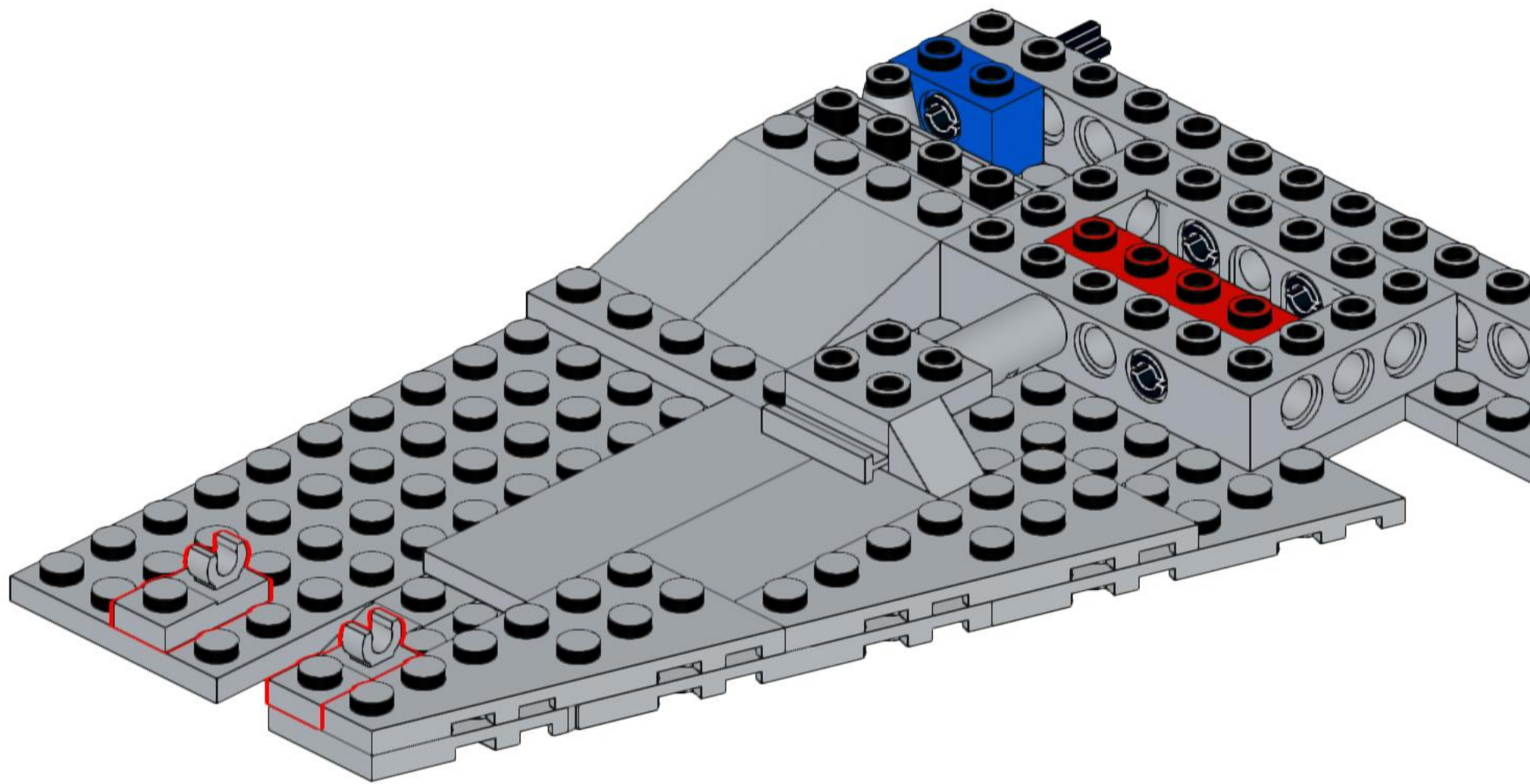
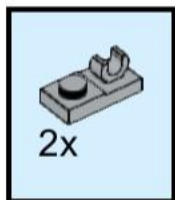

434

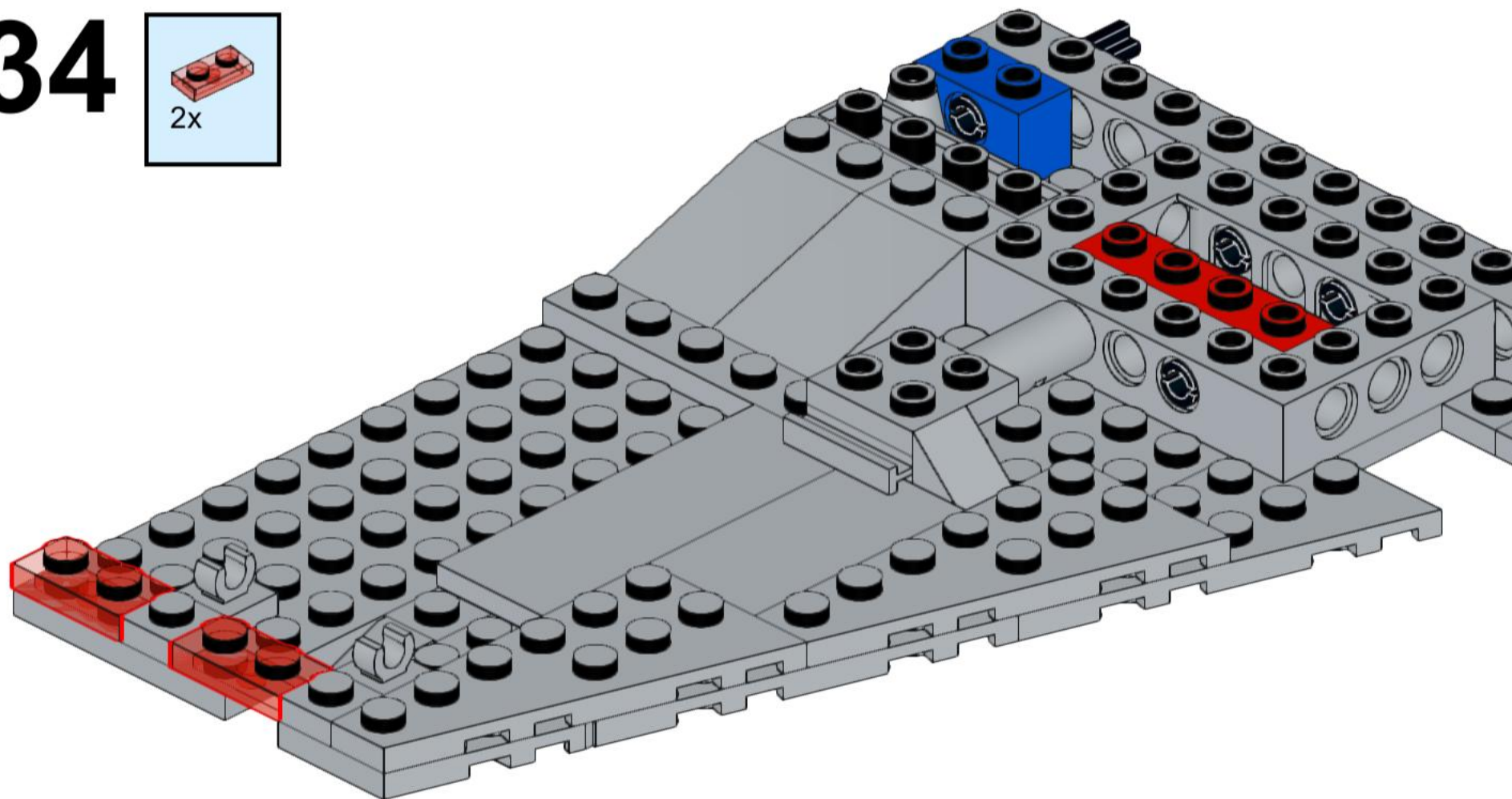
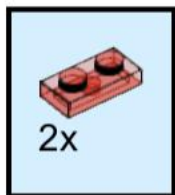

435

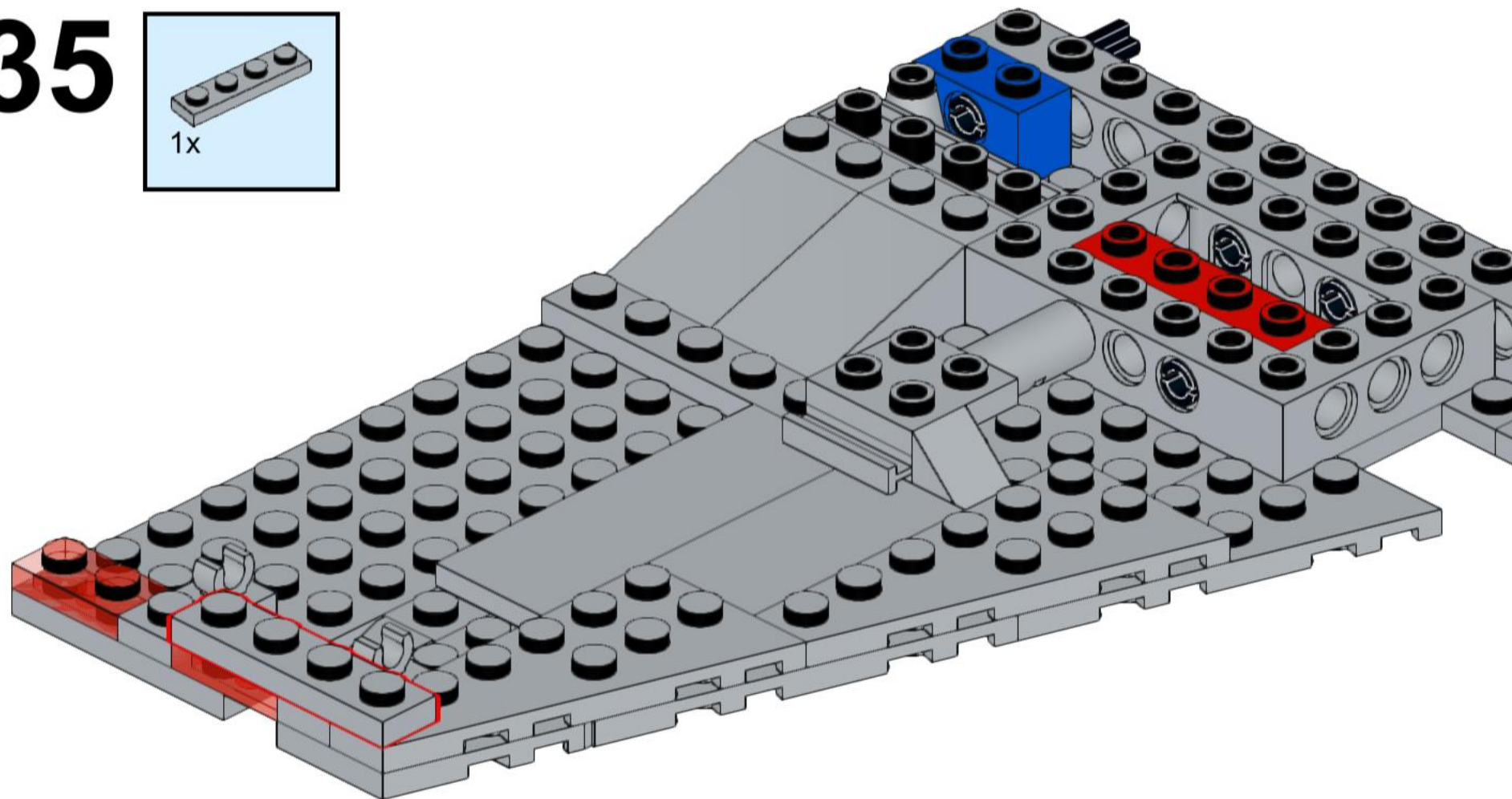
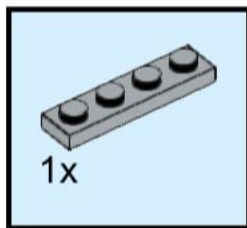

436

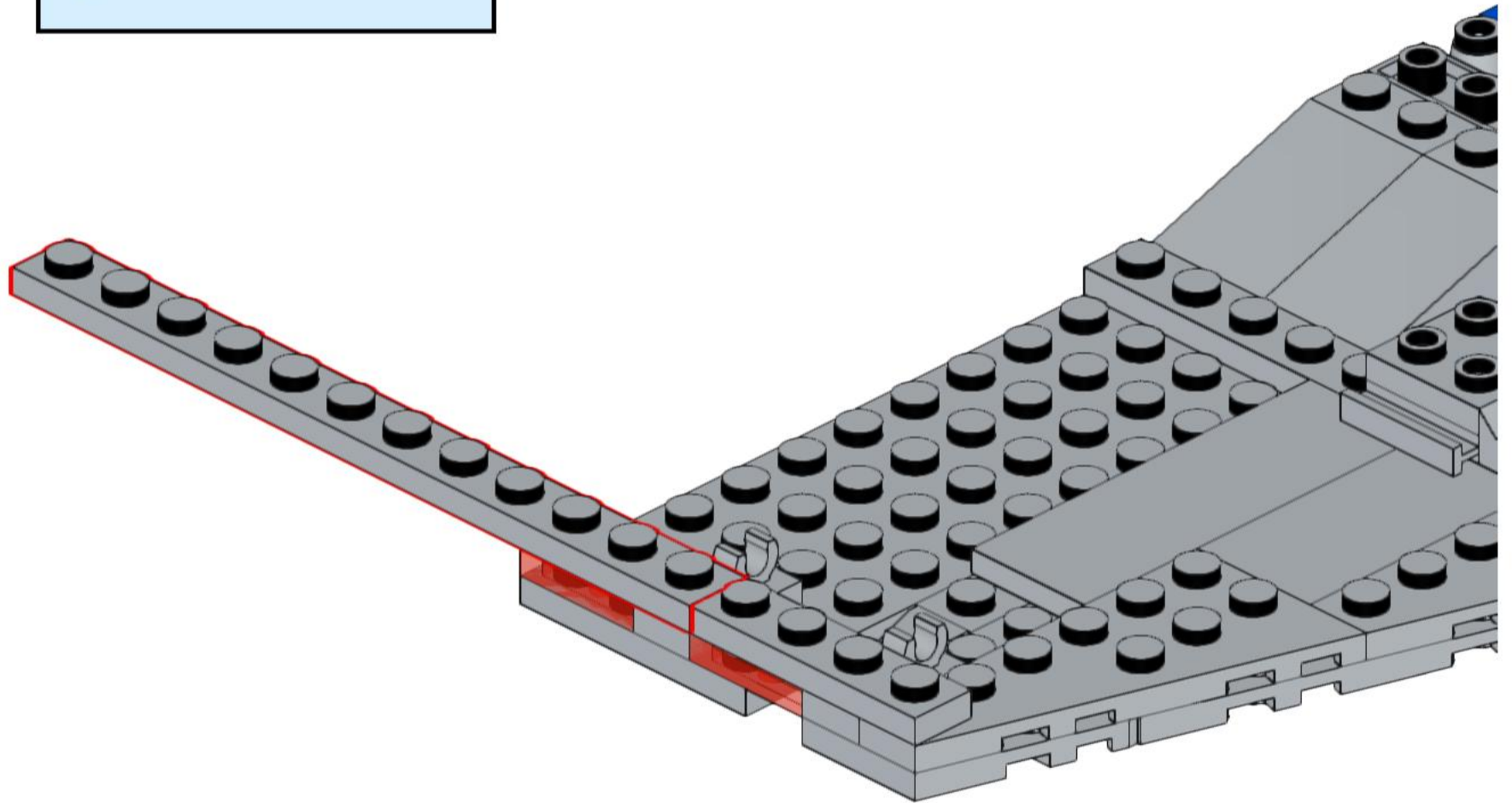
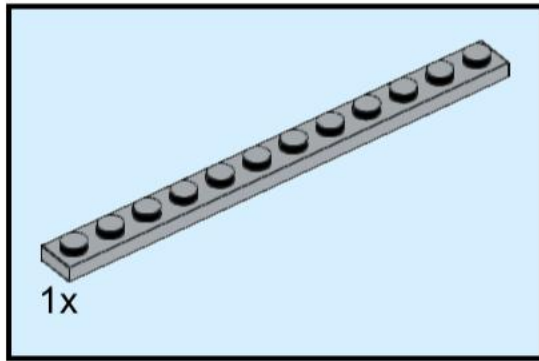

437

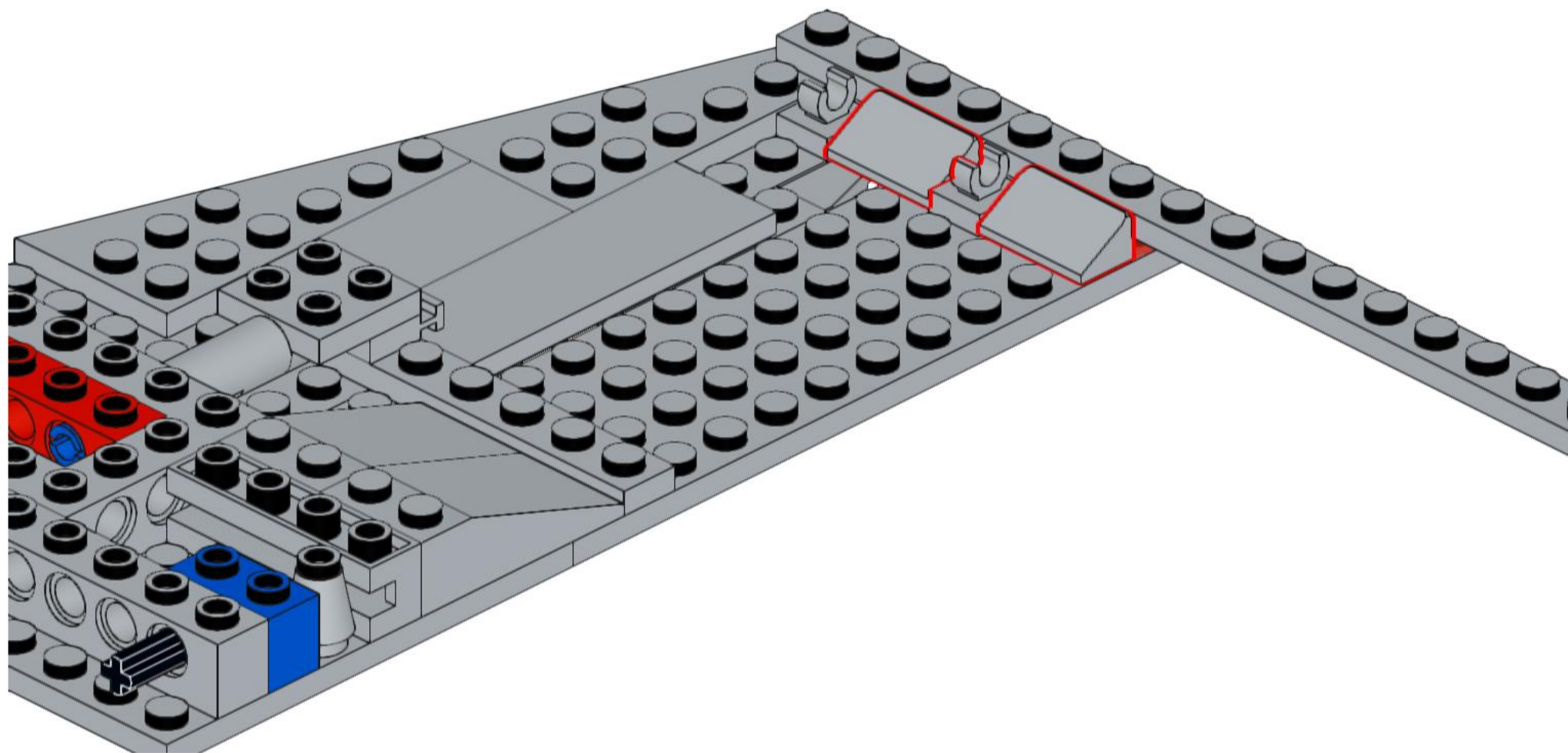
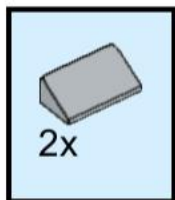

438

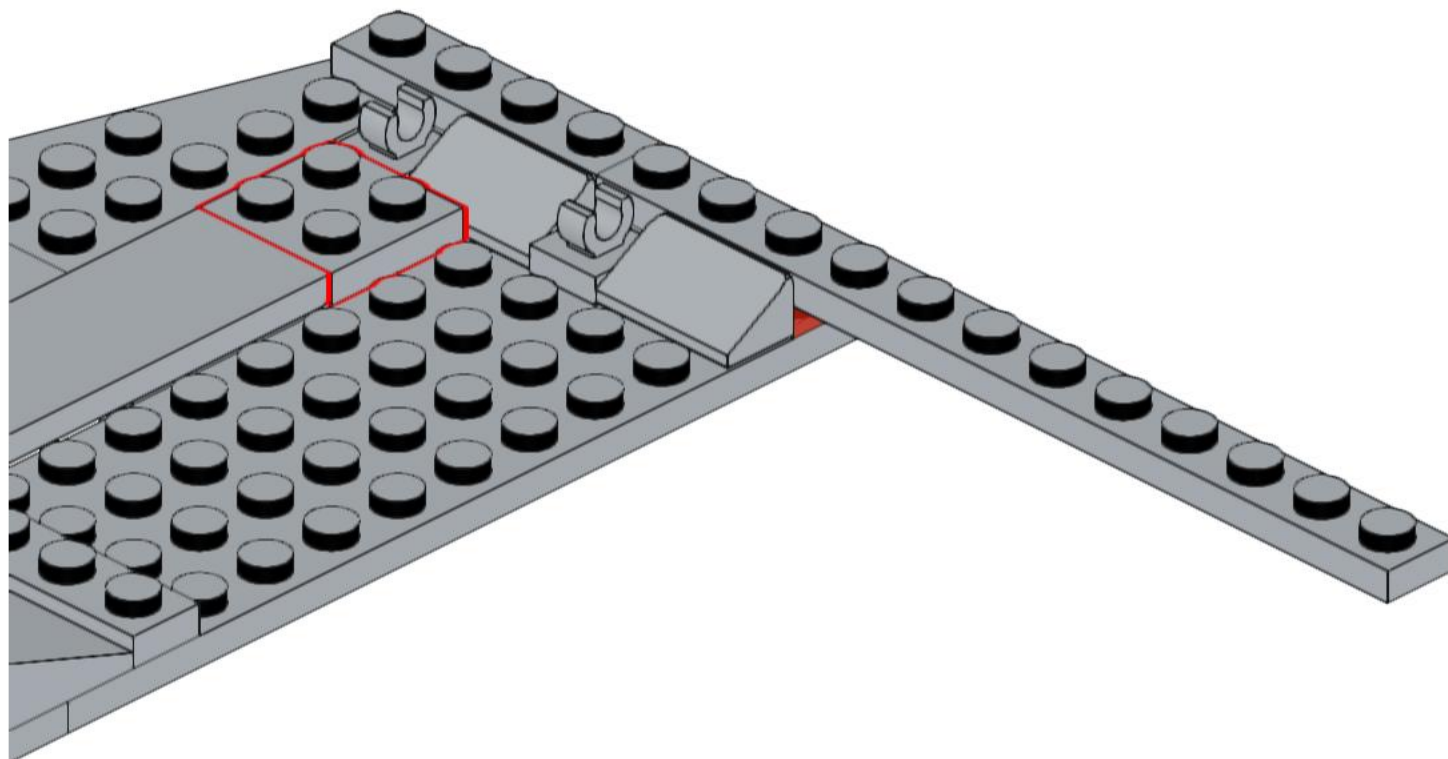
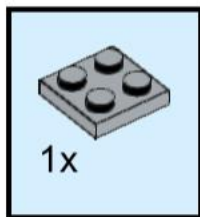

439

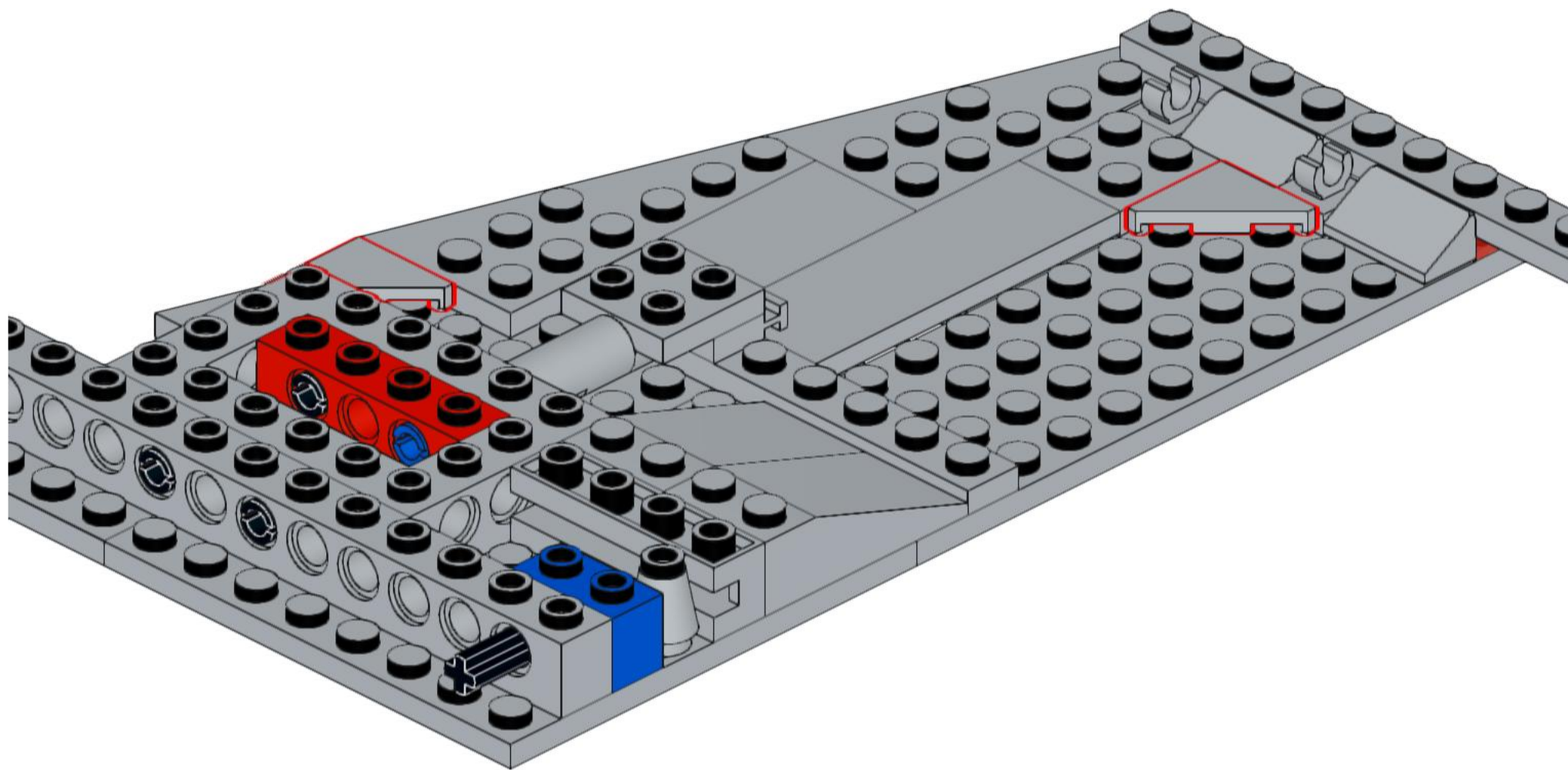
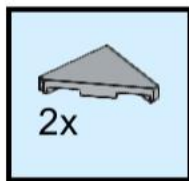

440

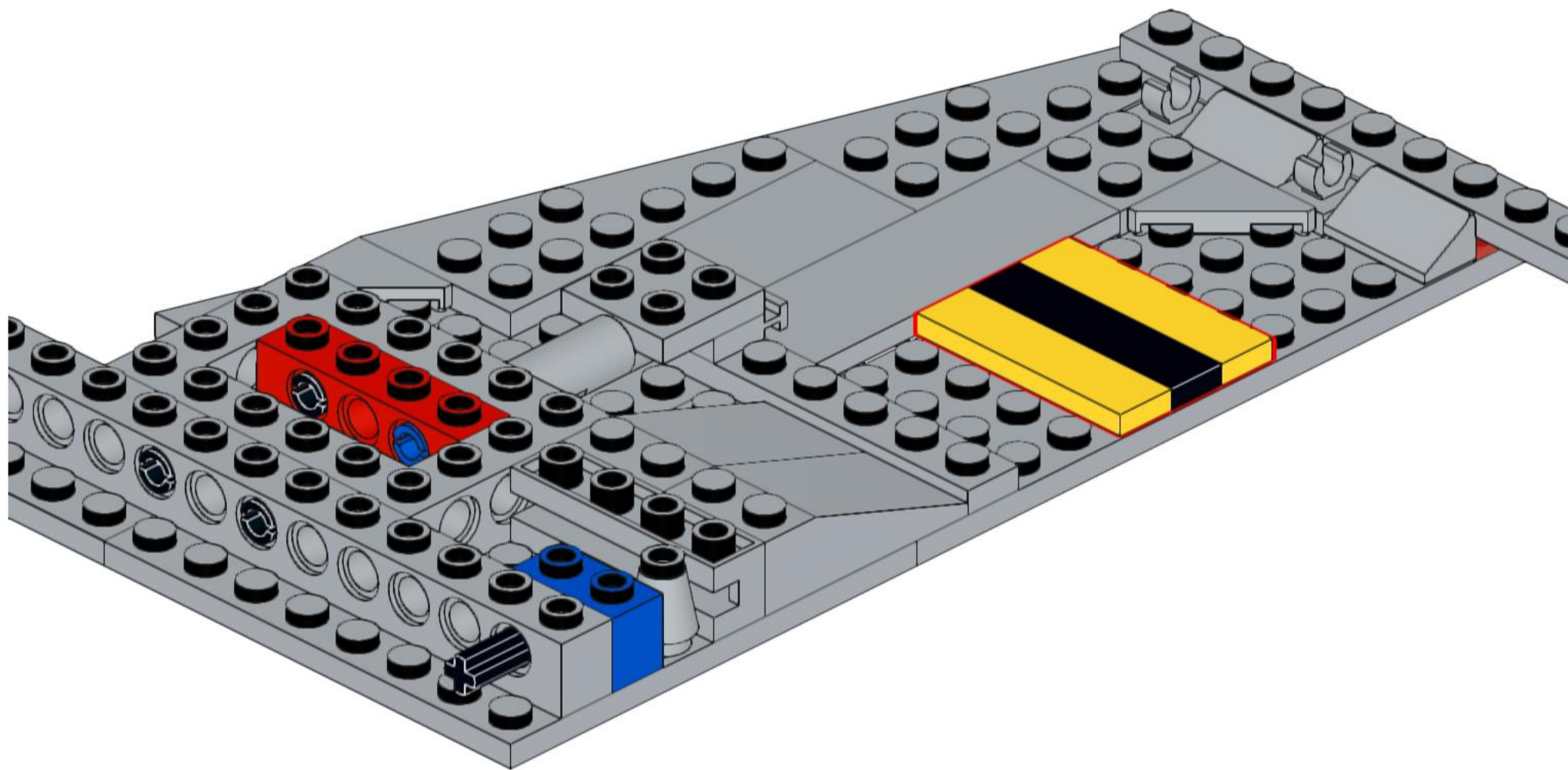
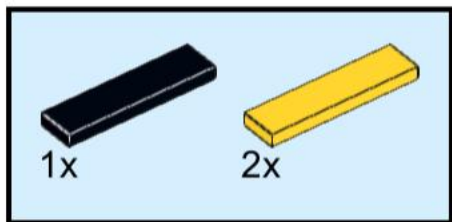

441

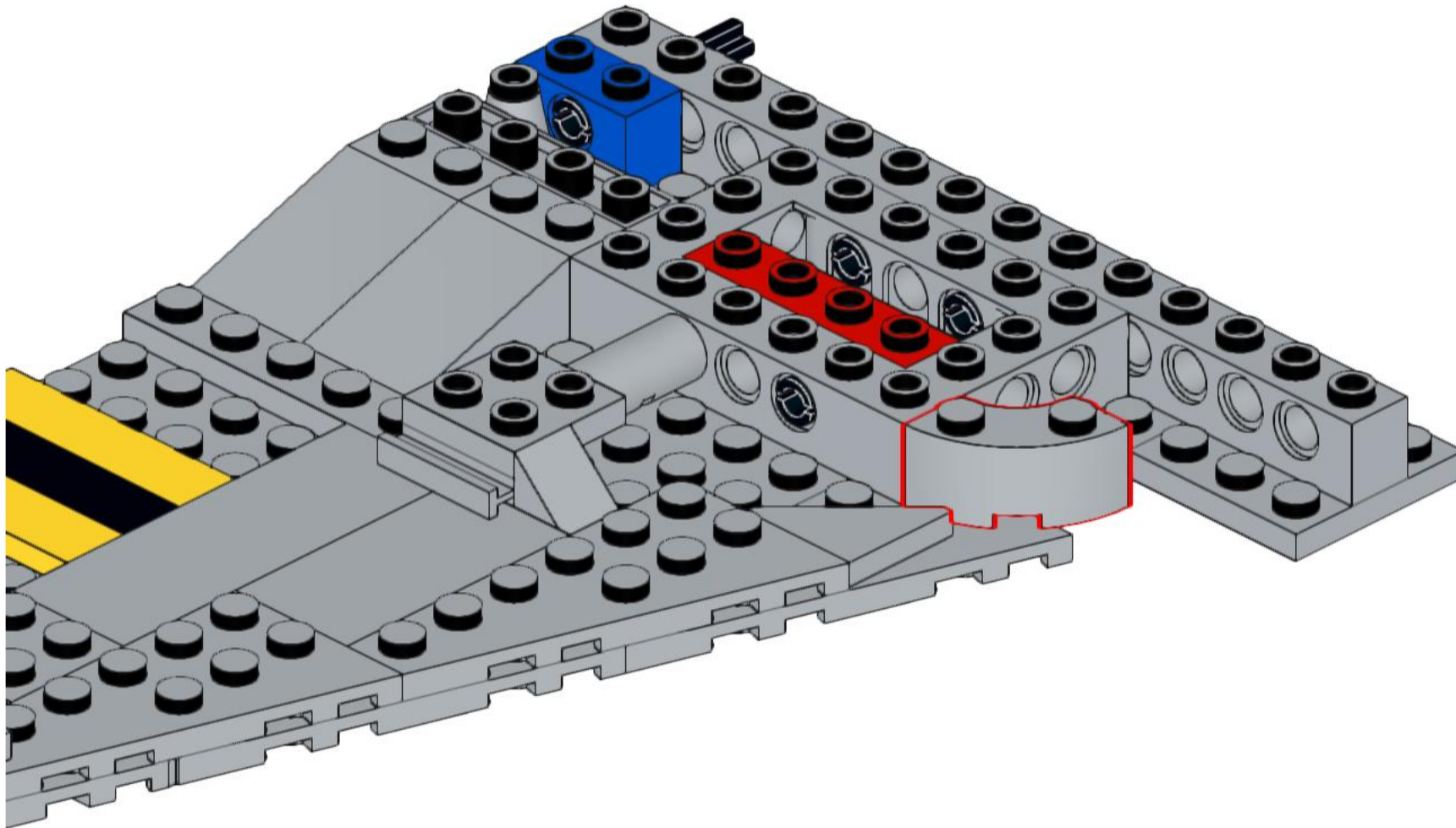
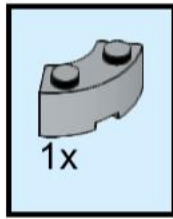

442

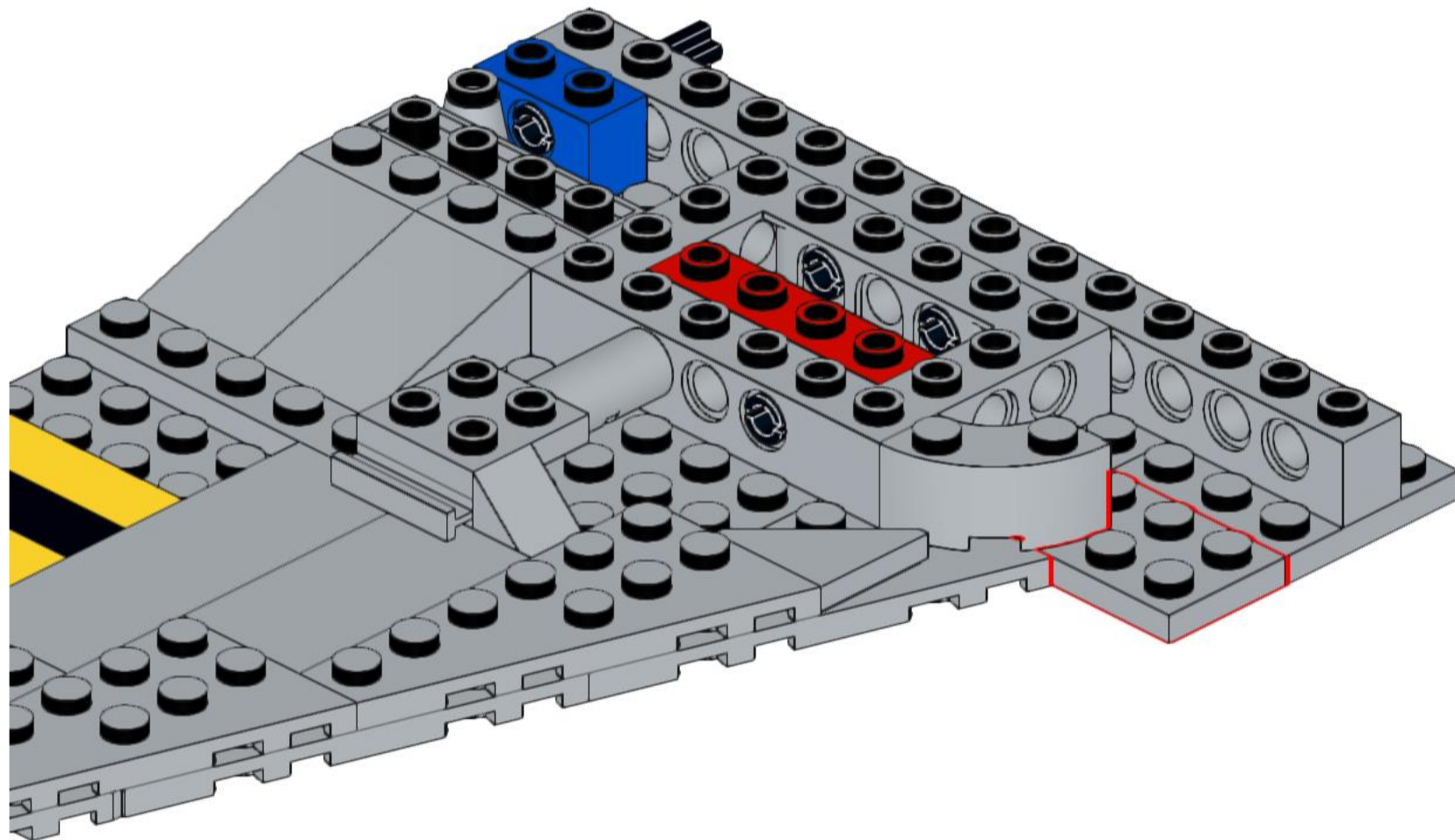
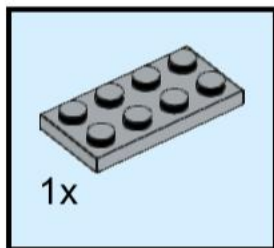

443

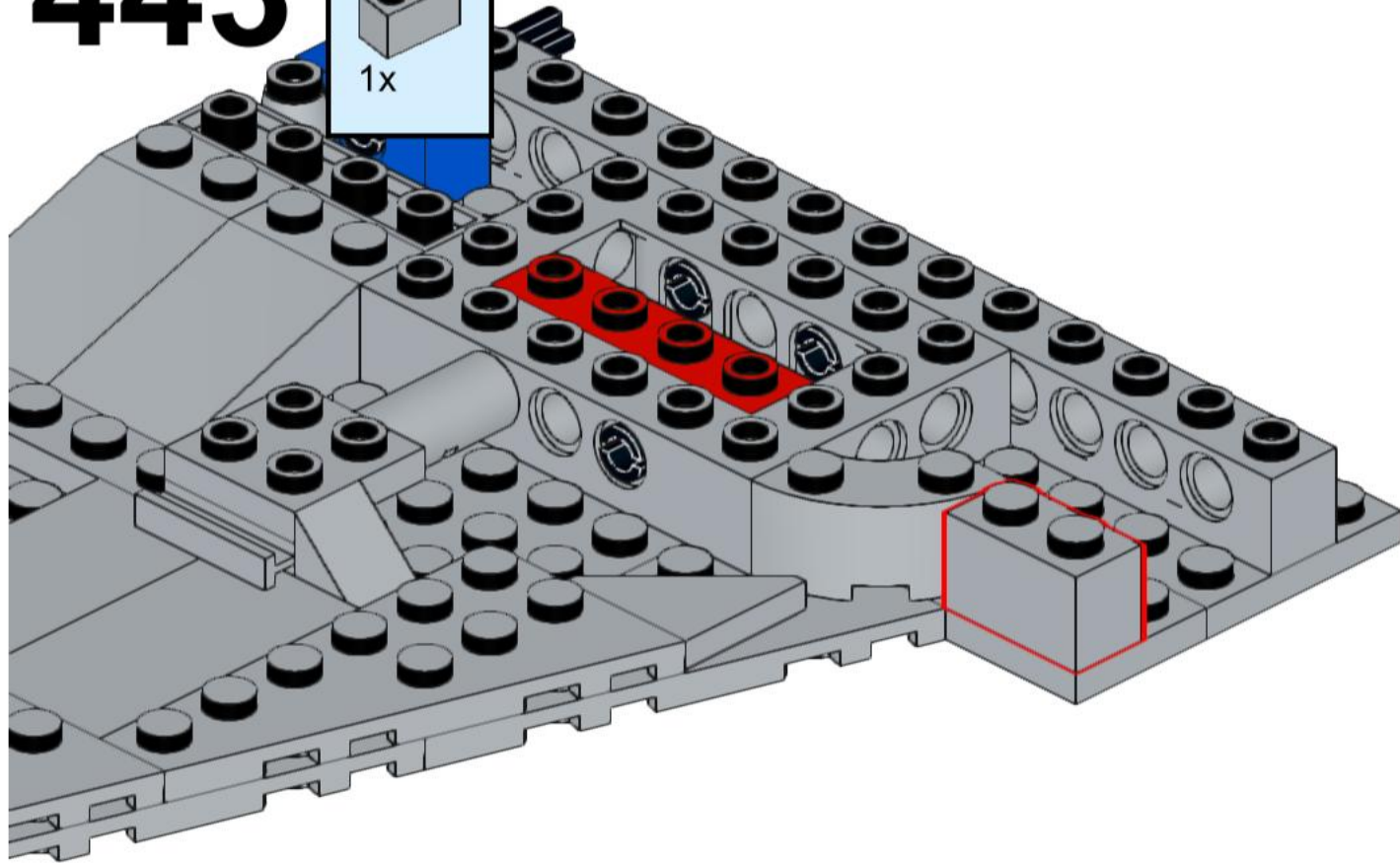
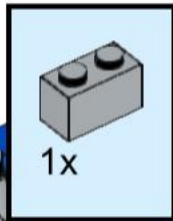

444

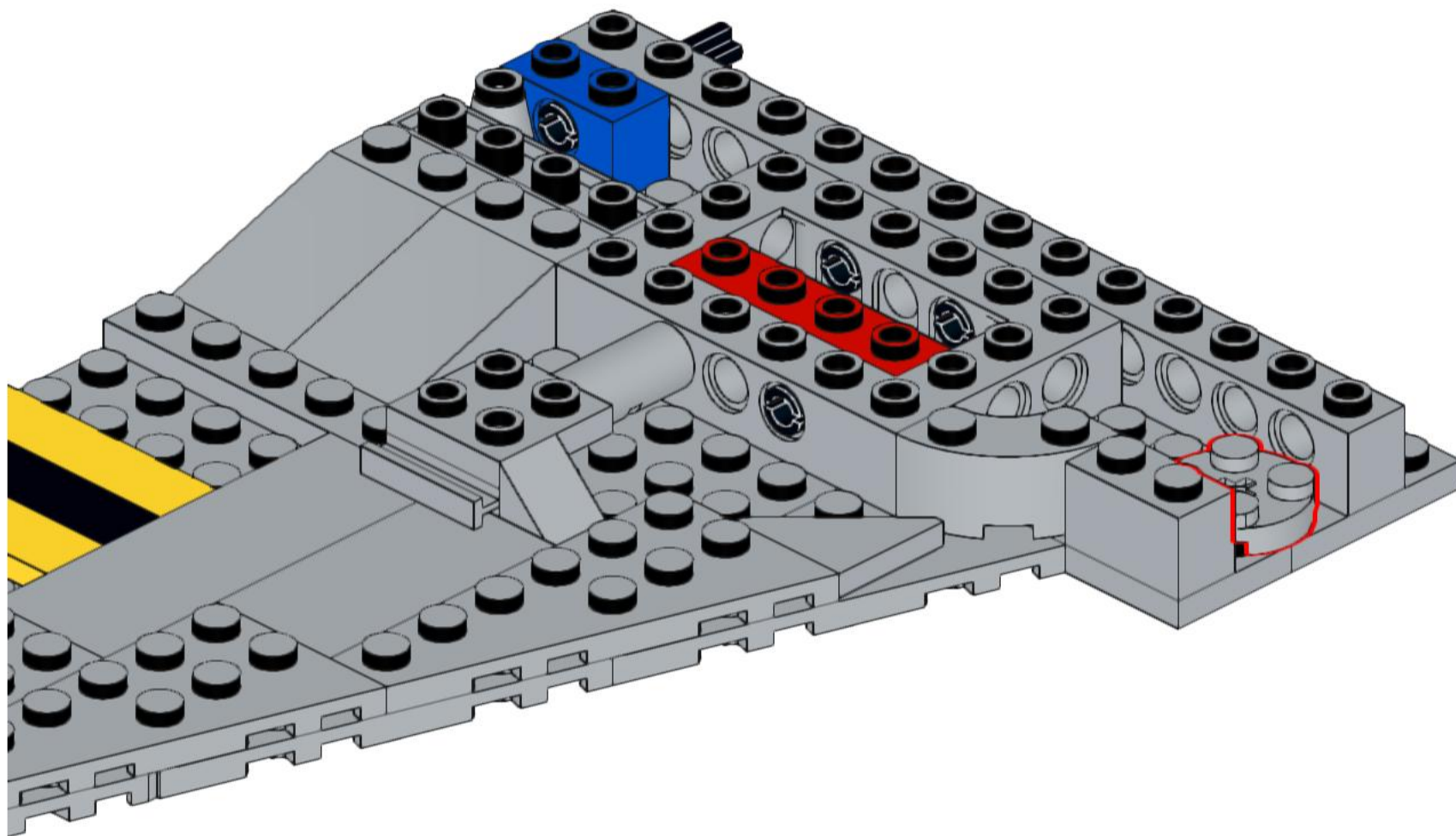
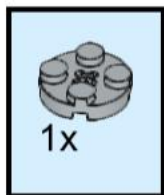

445

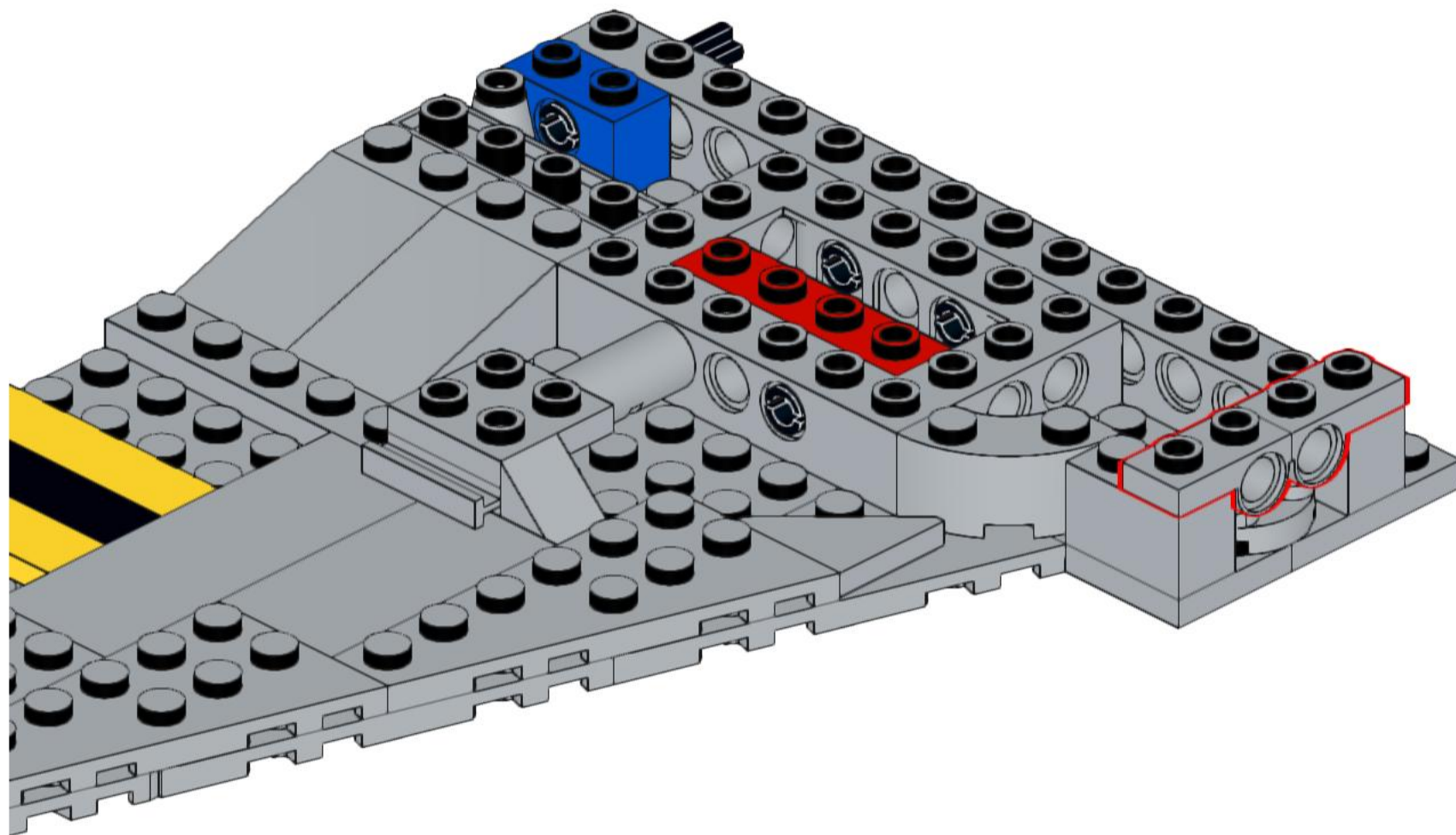
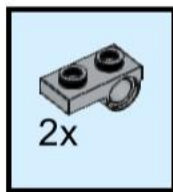

446

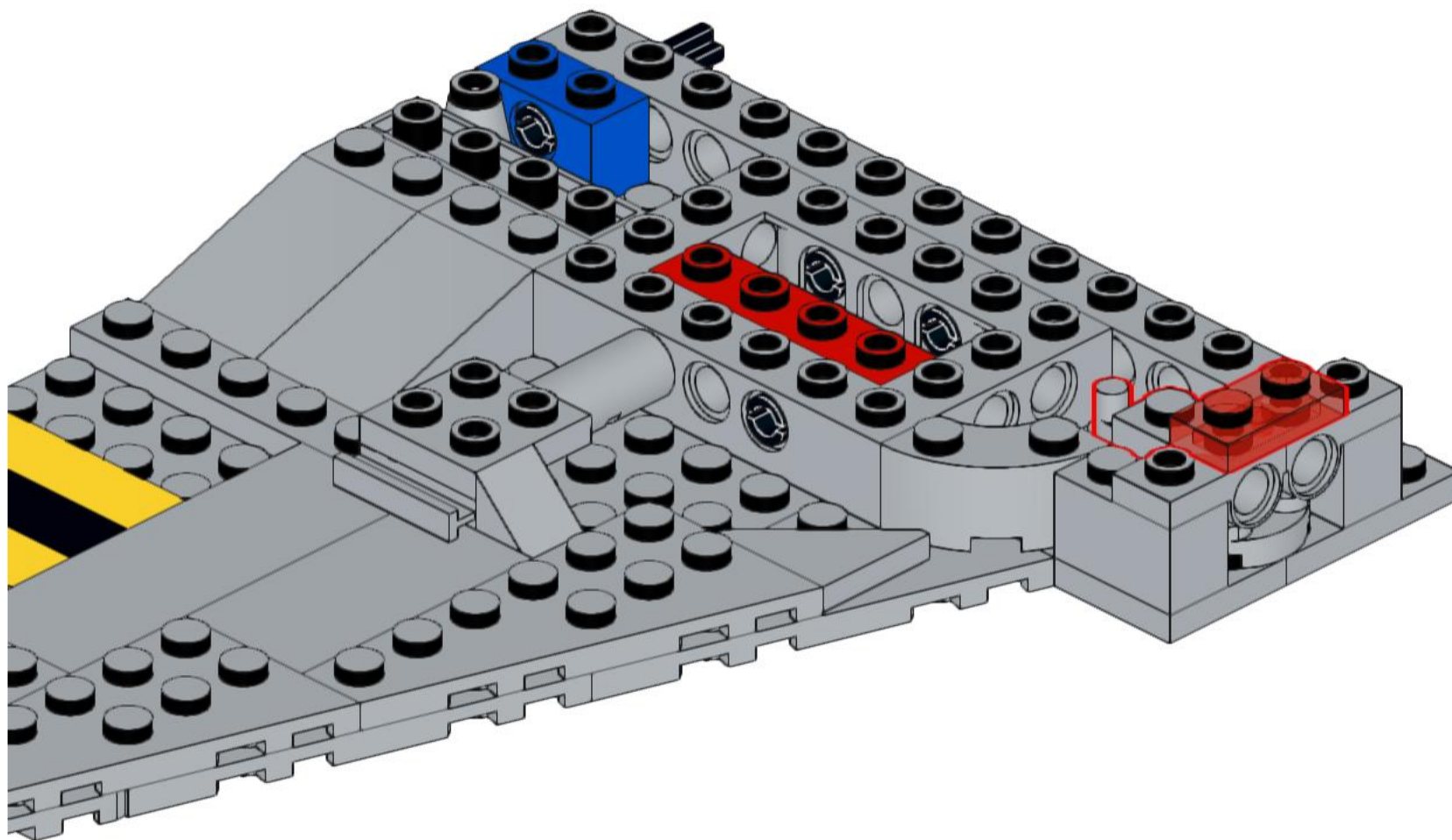
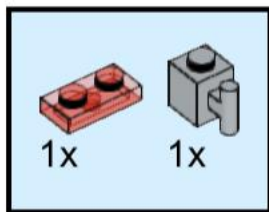

447

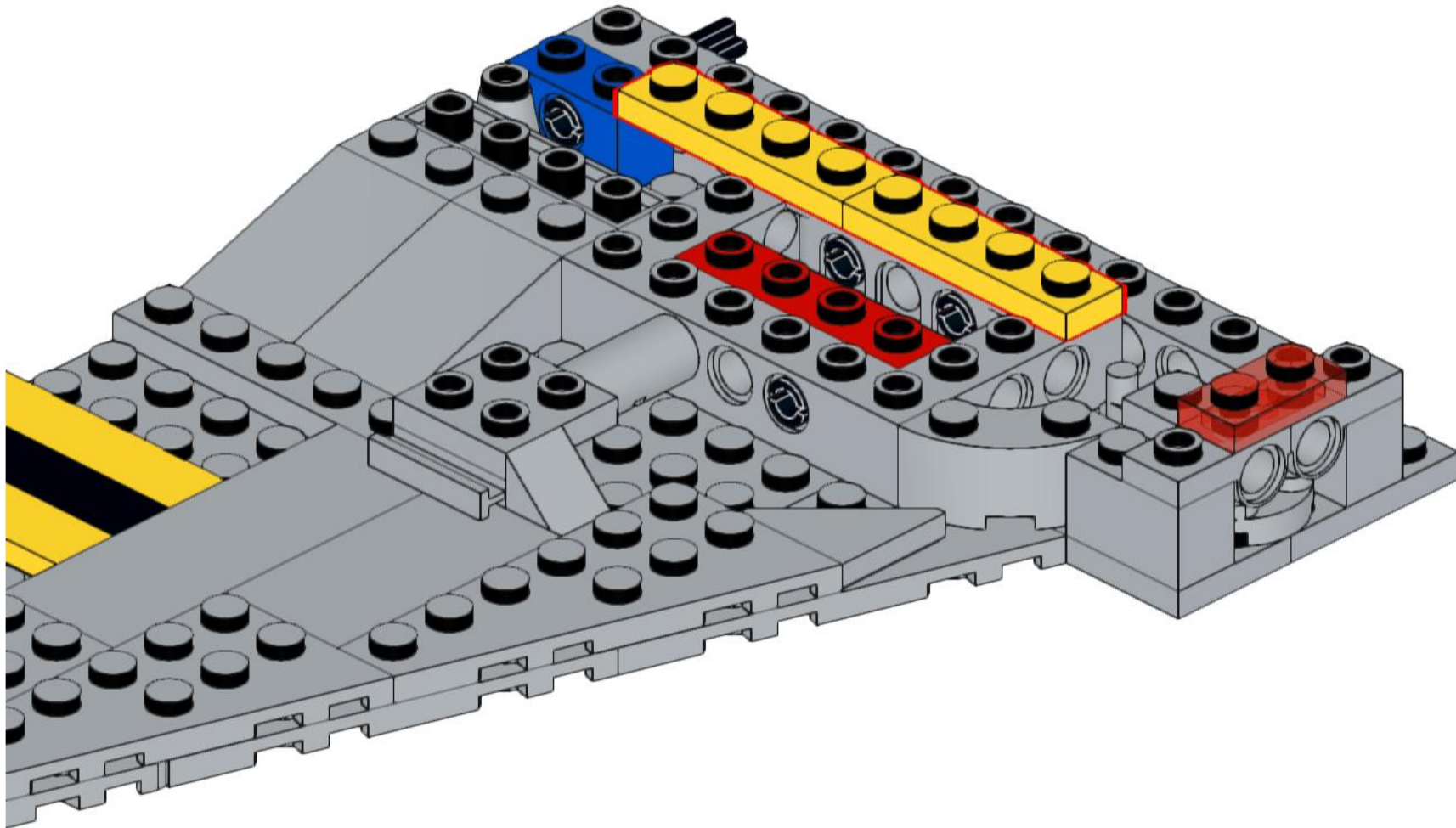
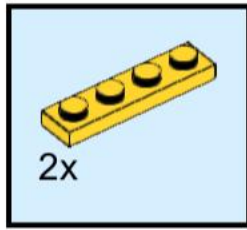

448

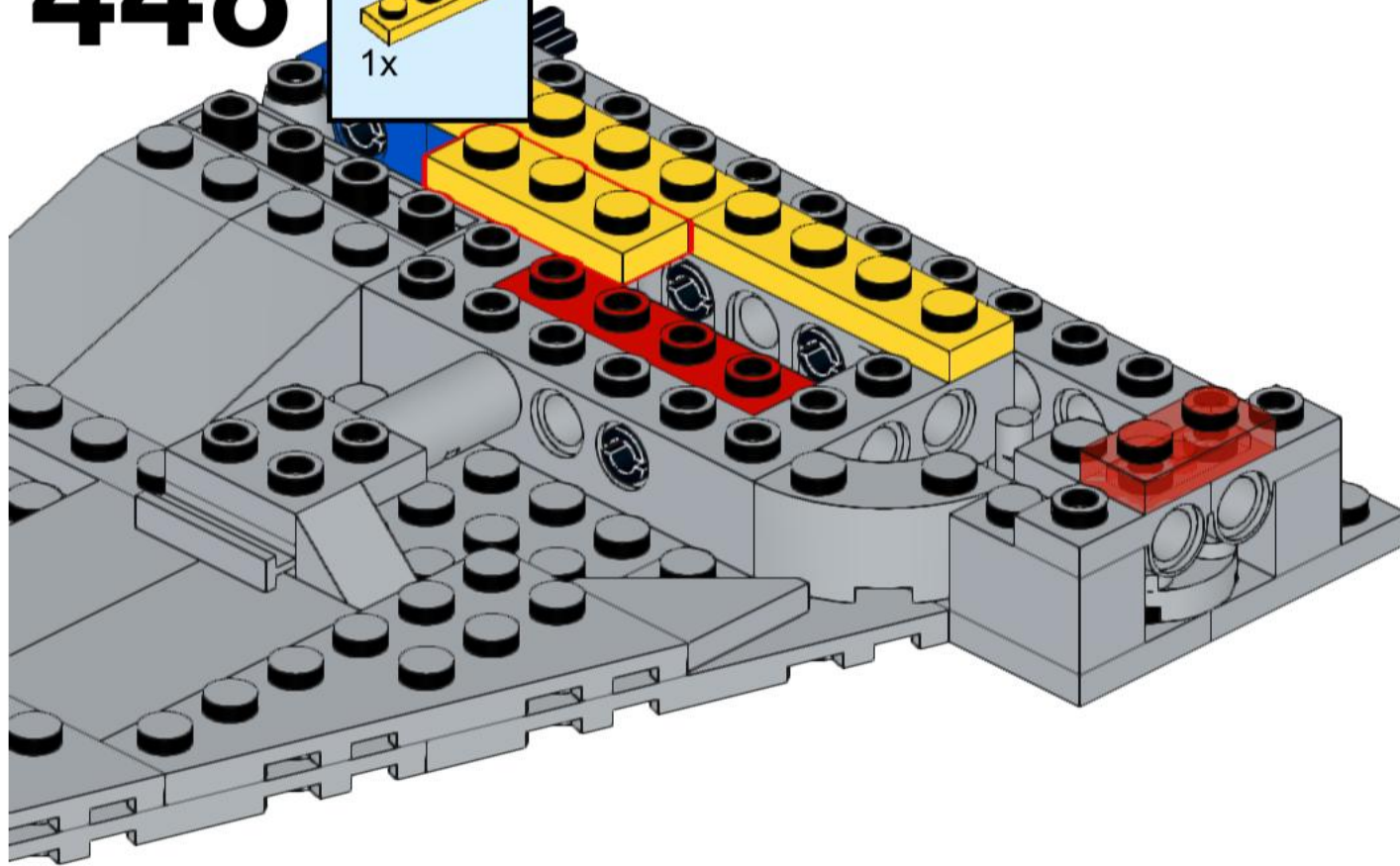
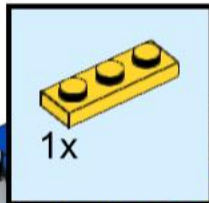

449

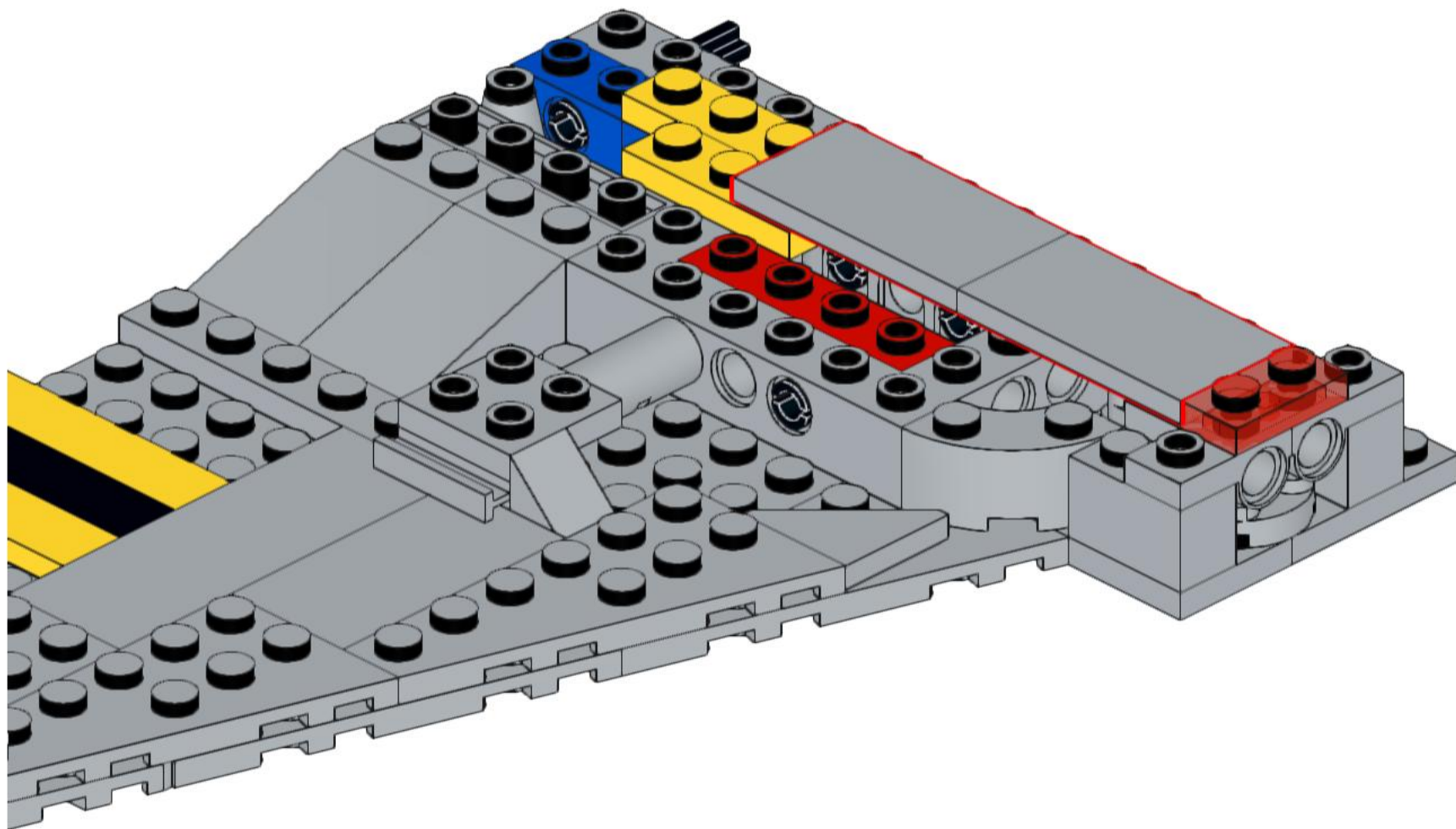
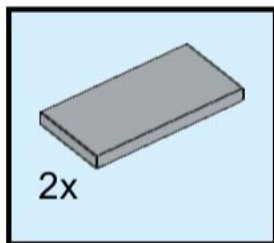

450

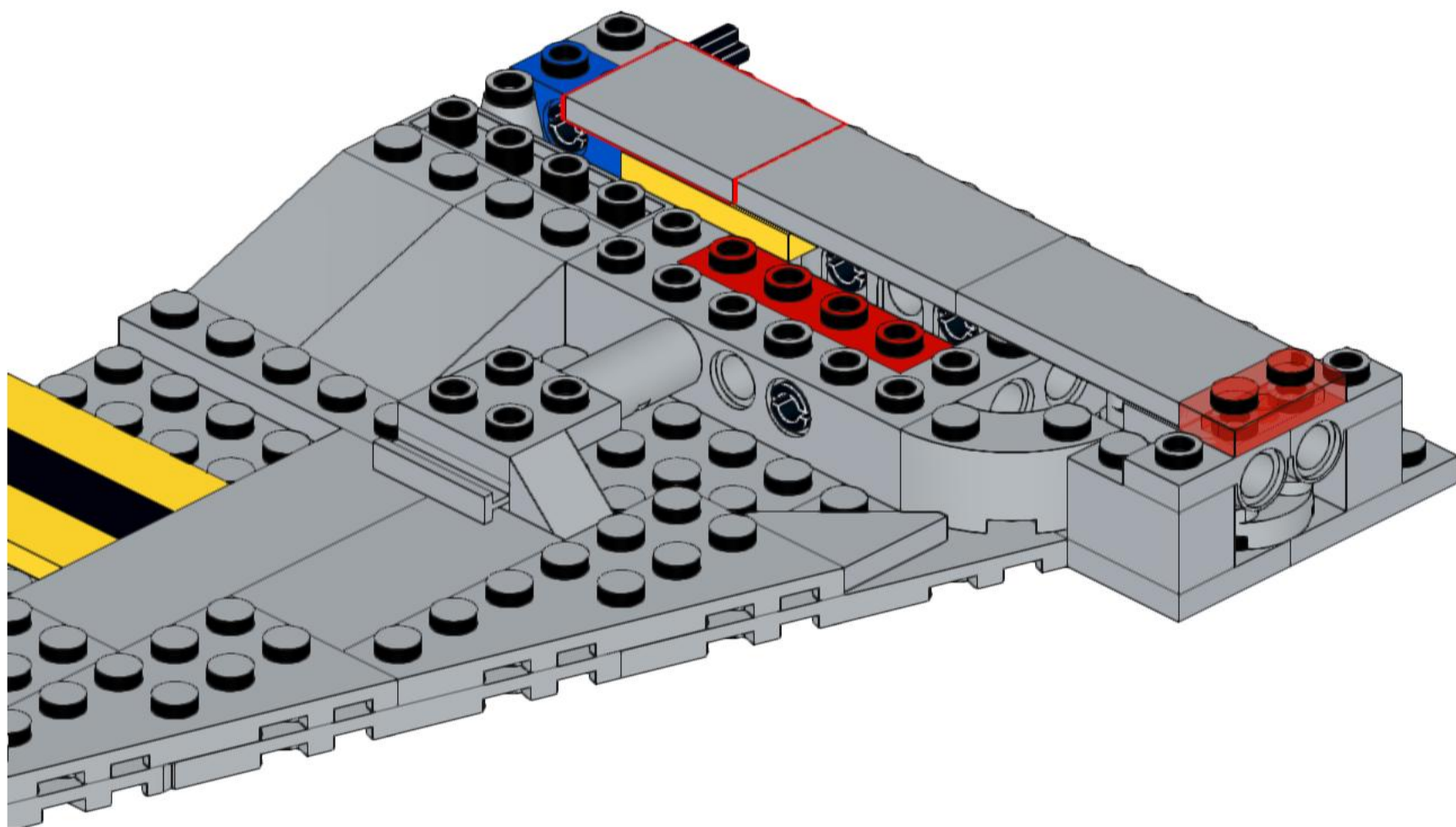
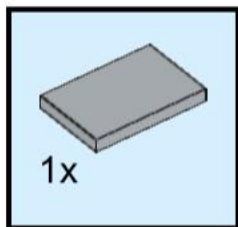

451

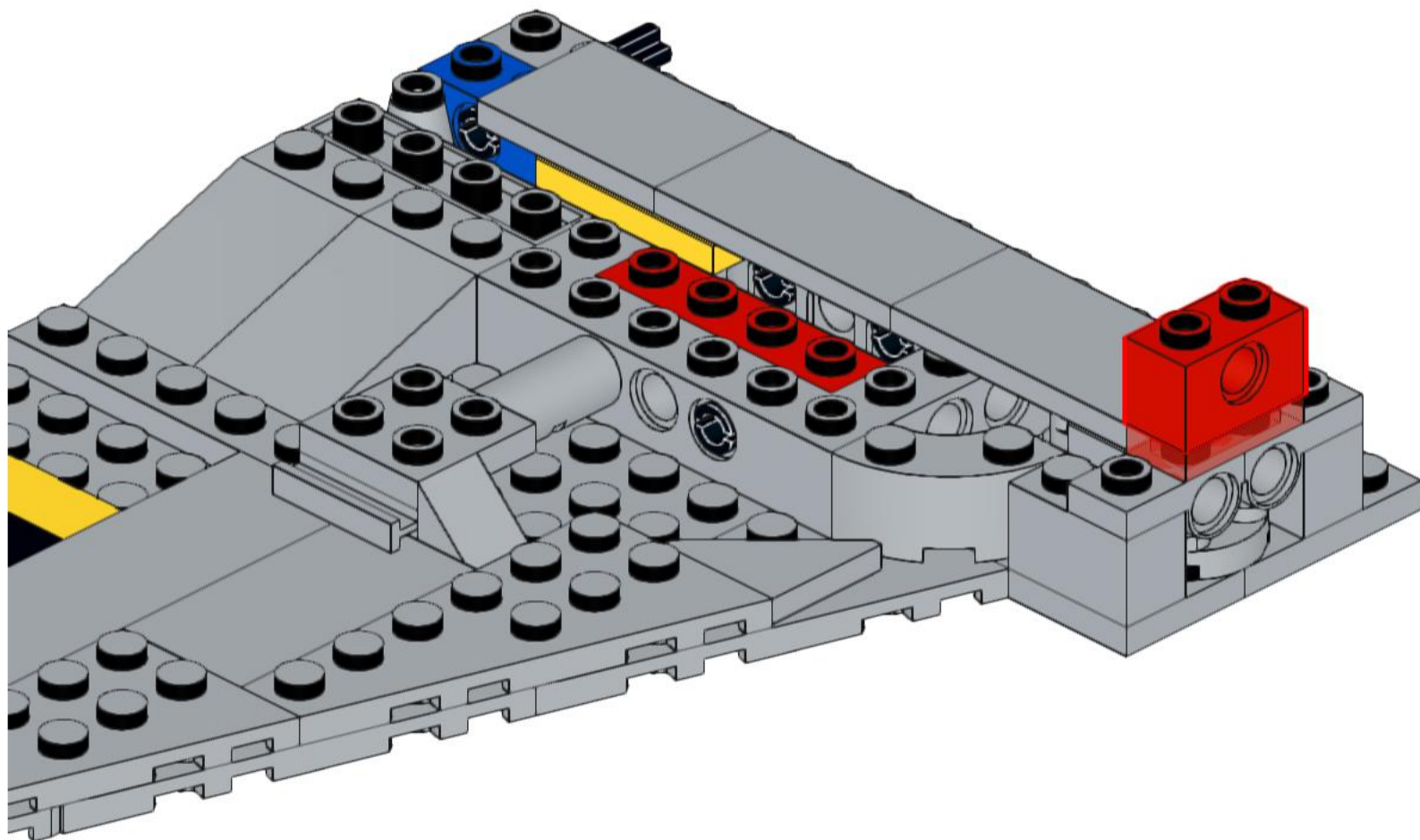
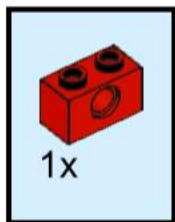

452

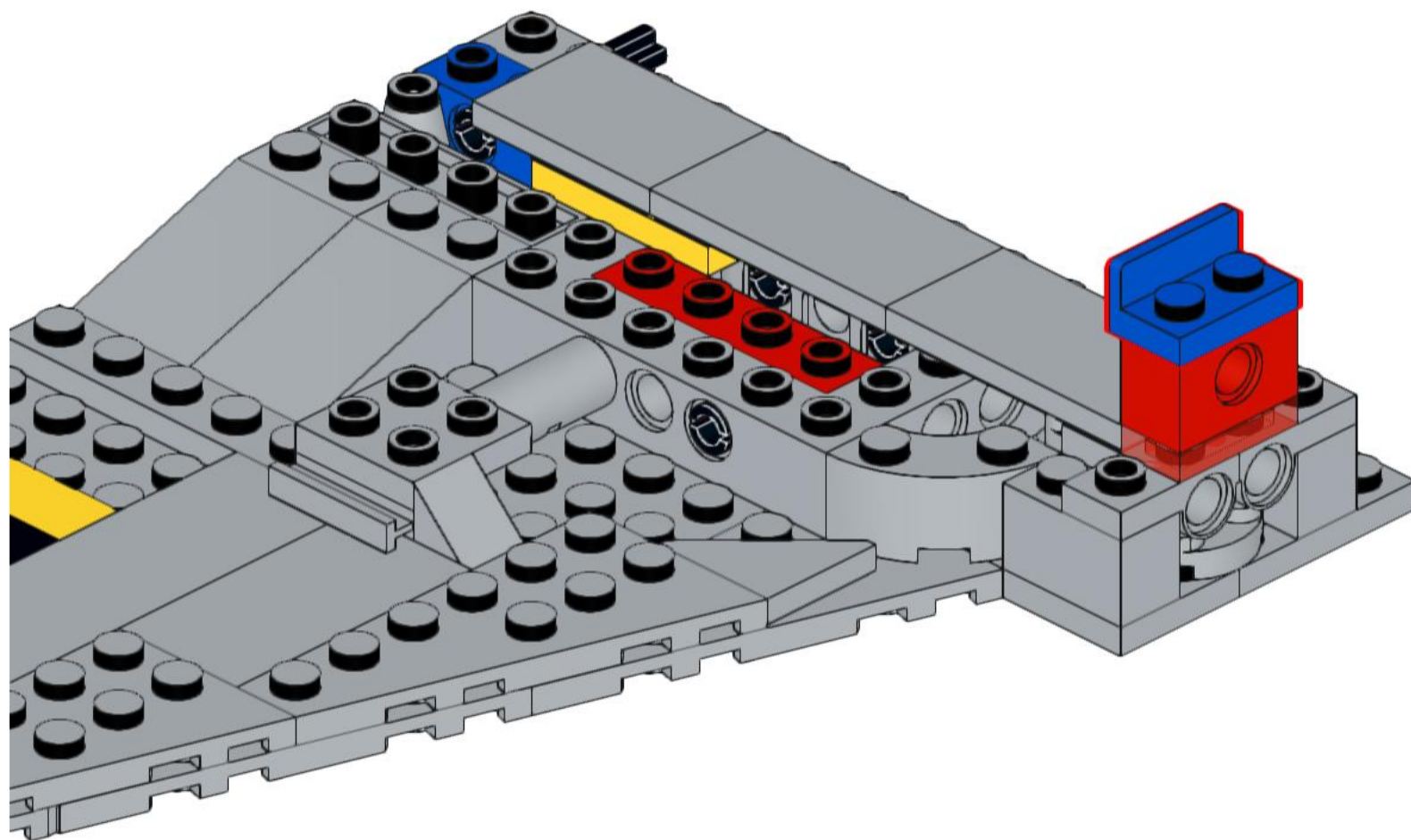
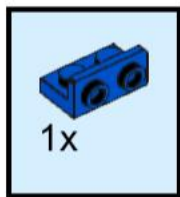

453

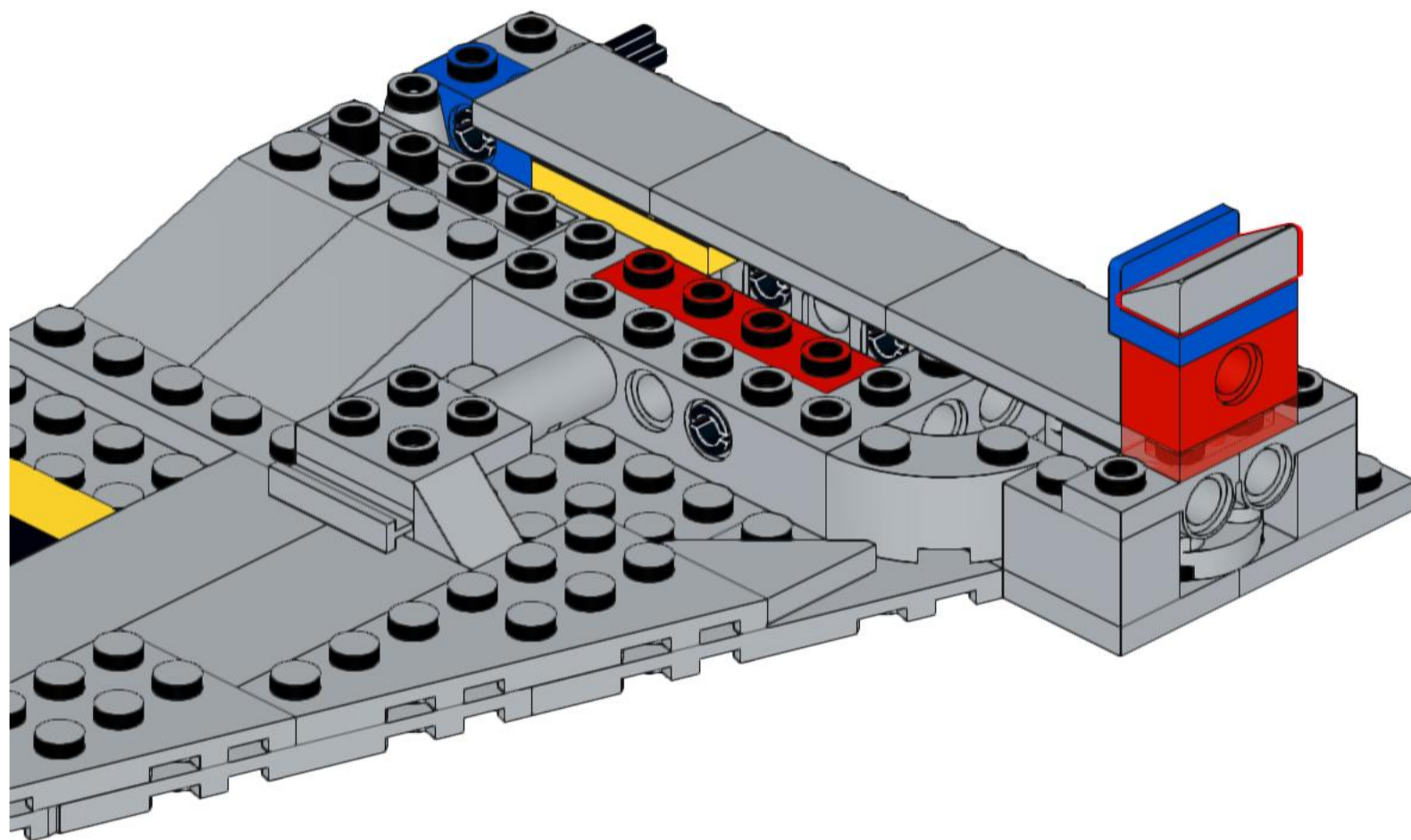
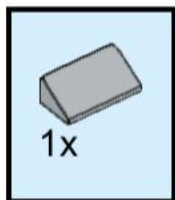

454

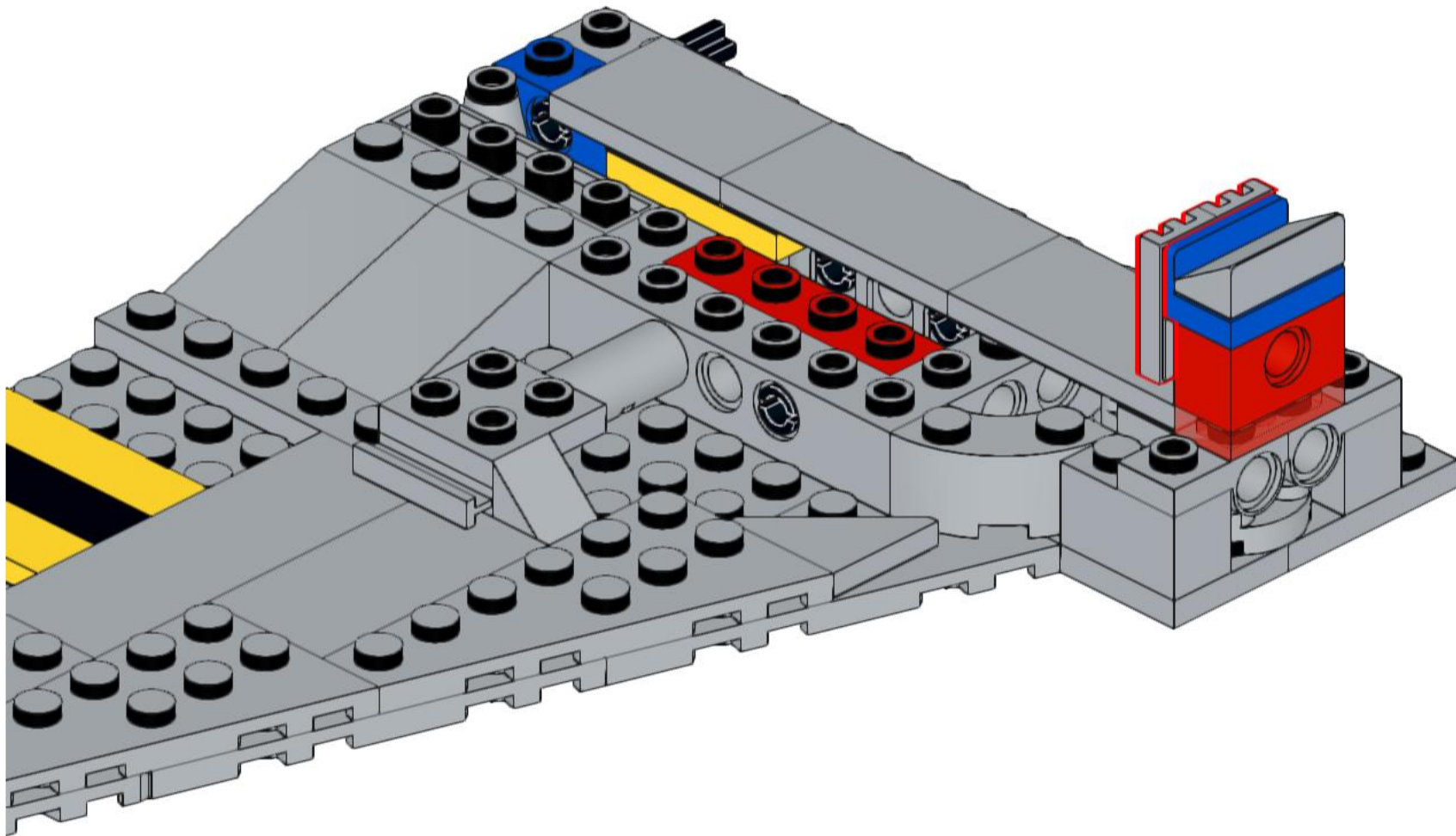
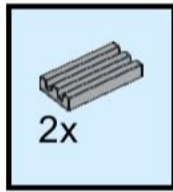

455

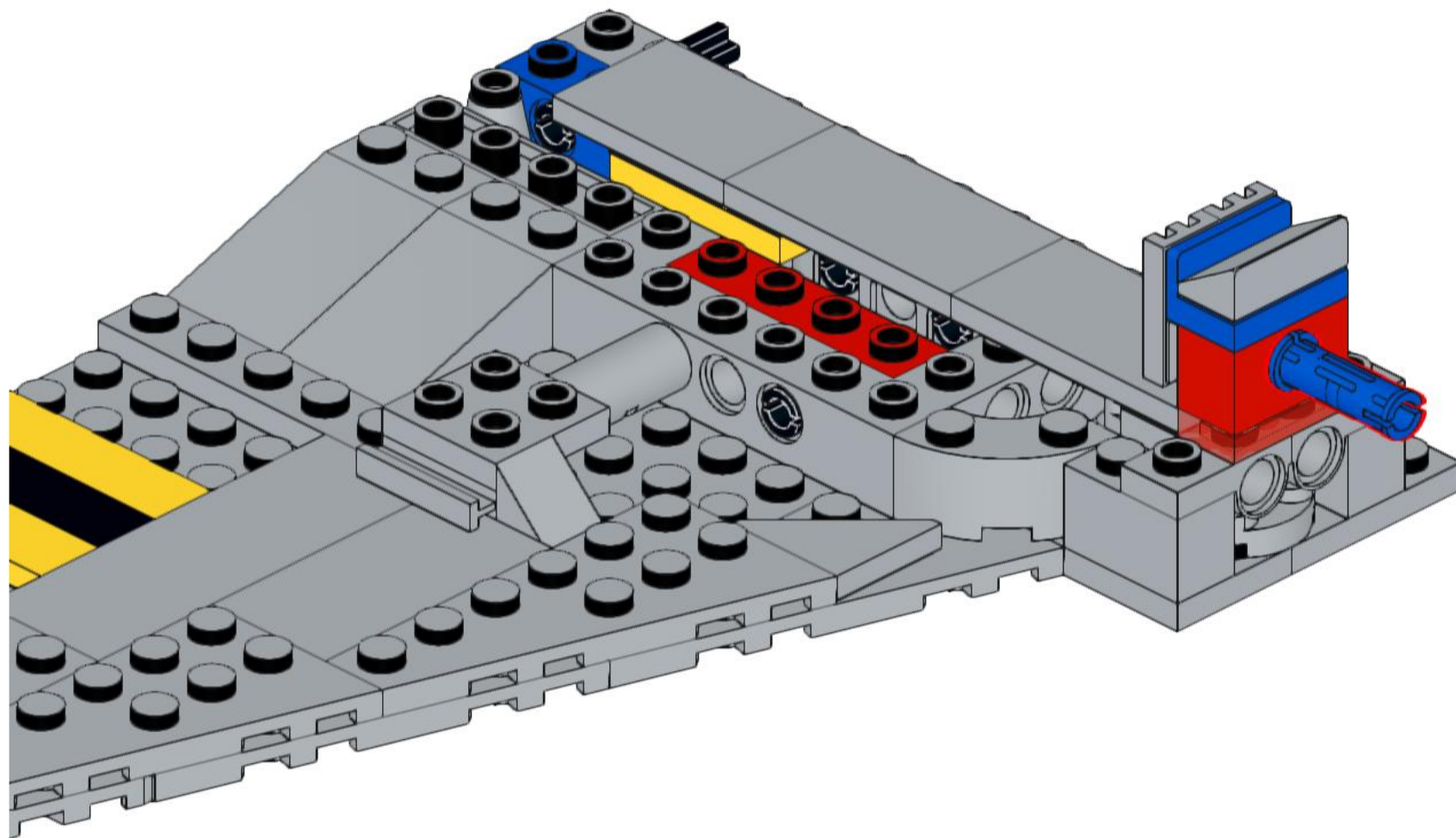
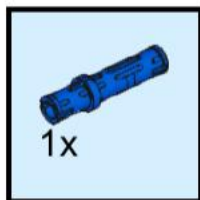

456

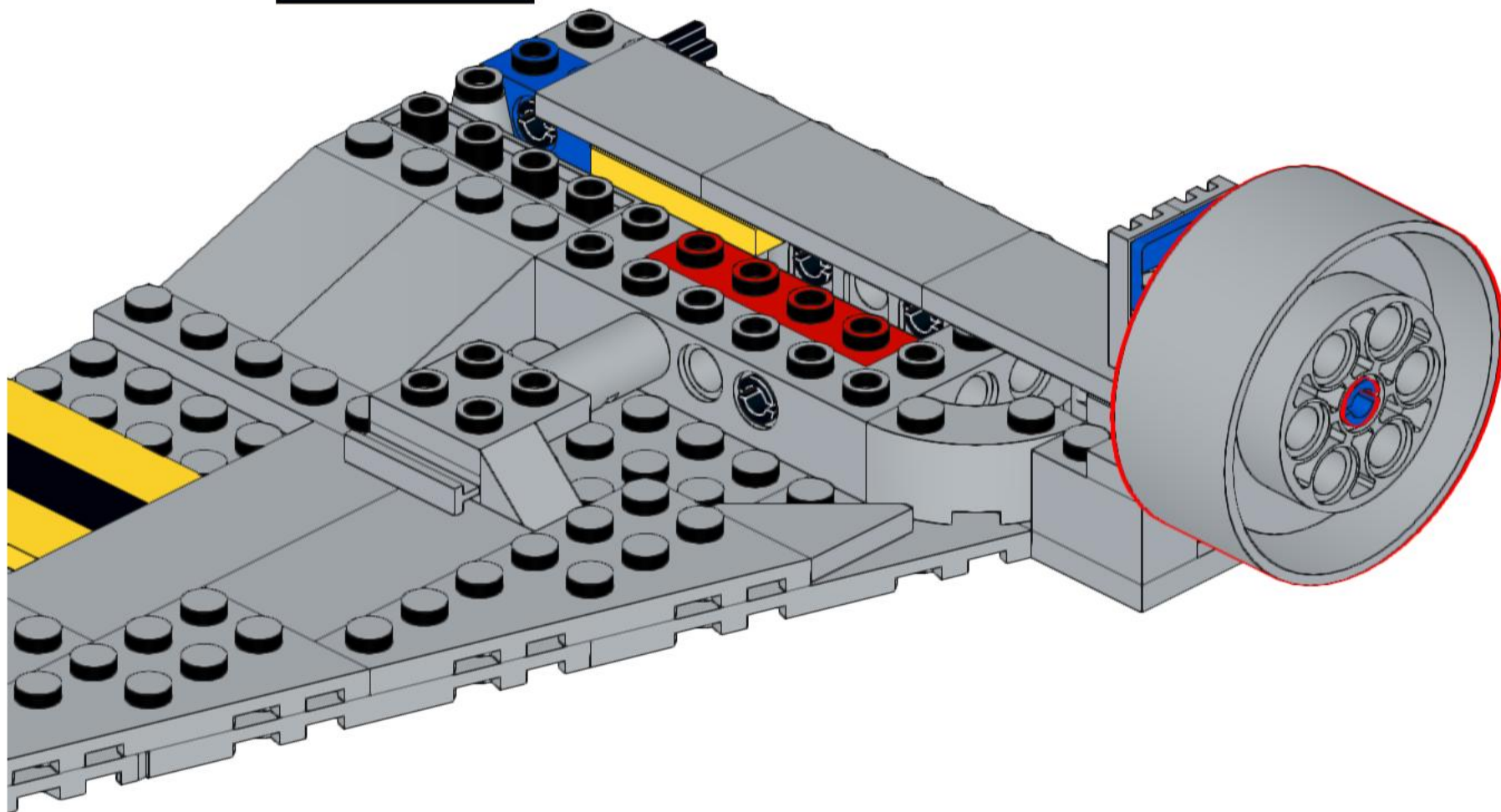
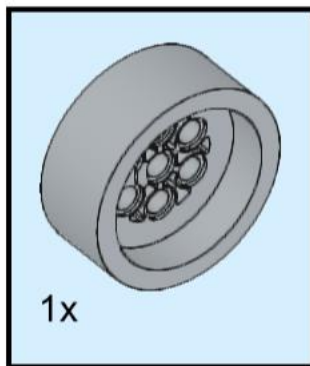

457

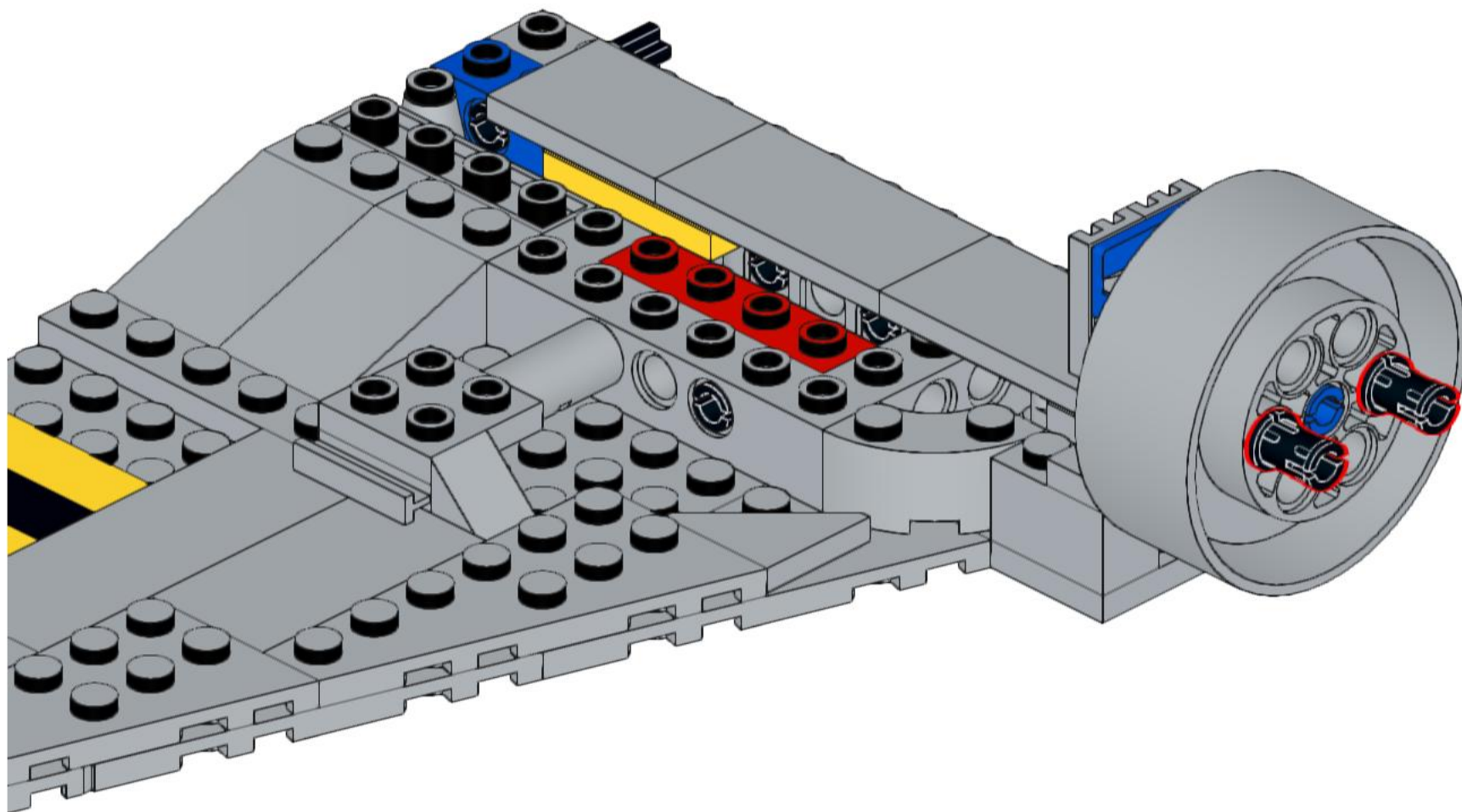

458

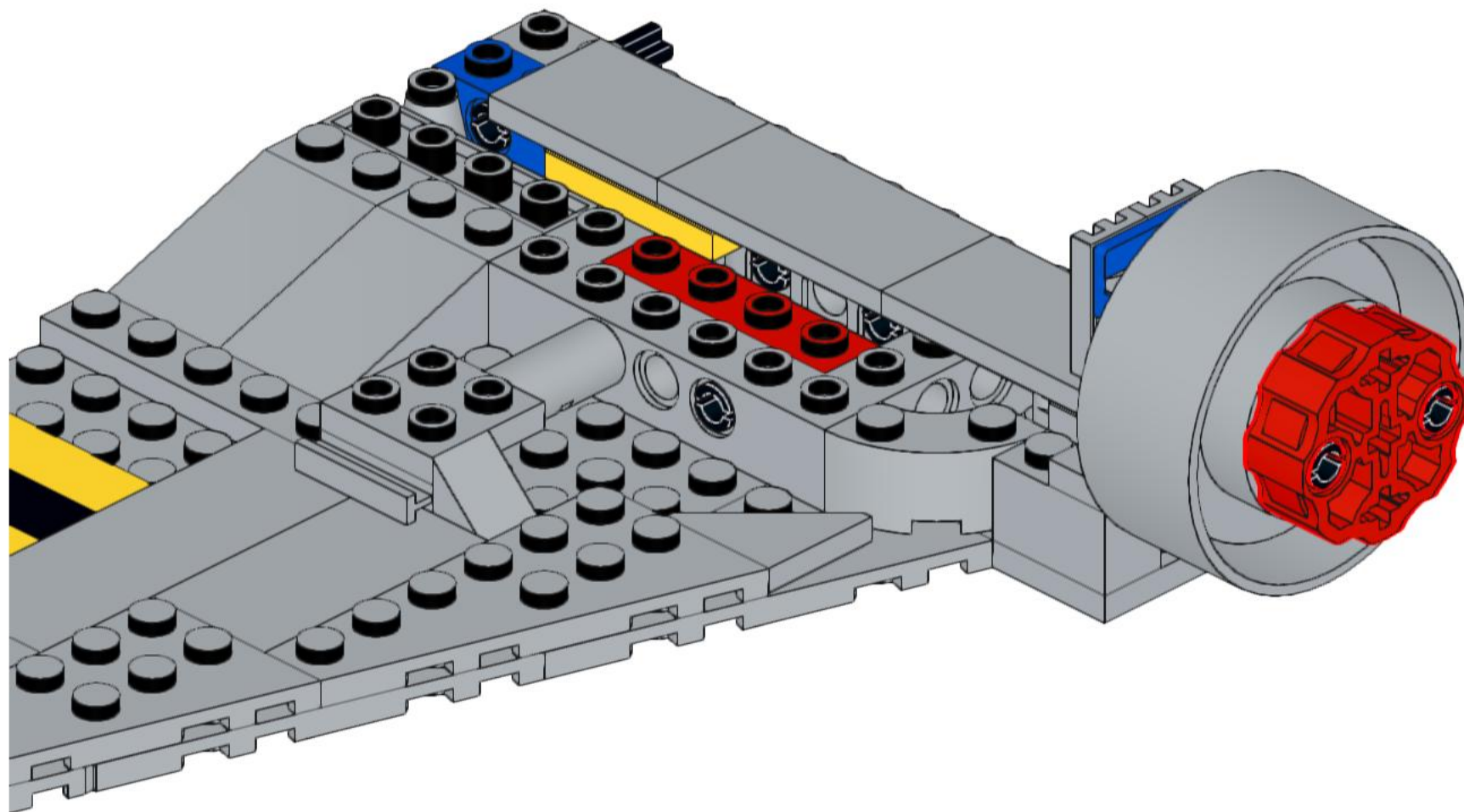
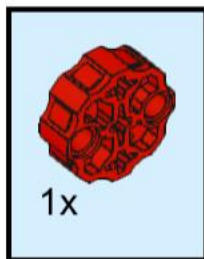

459

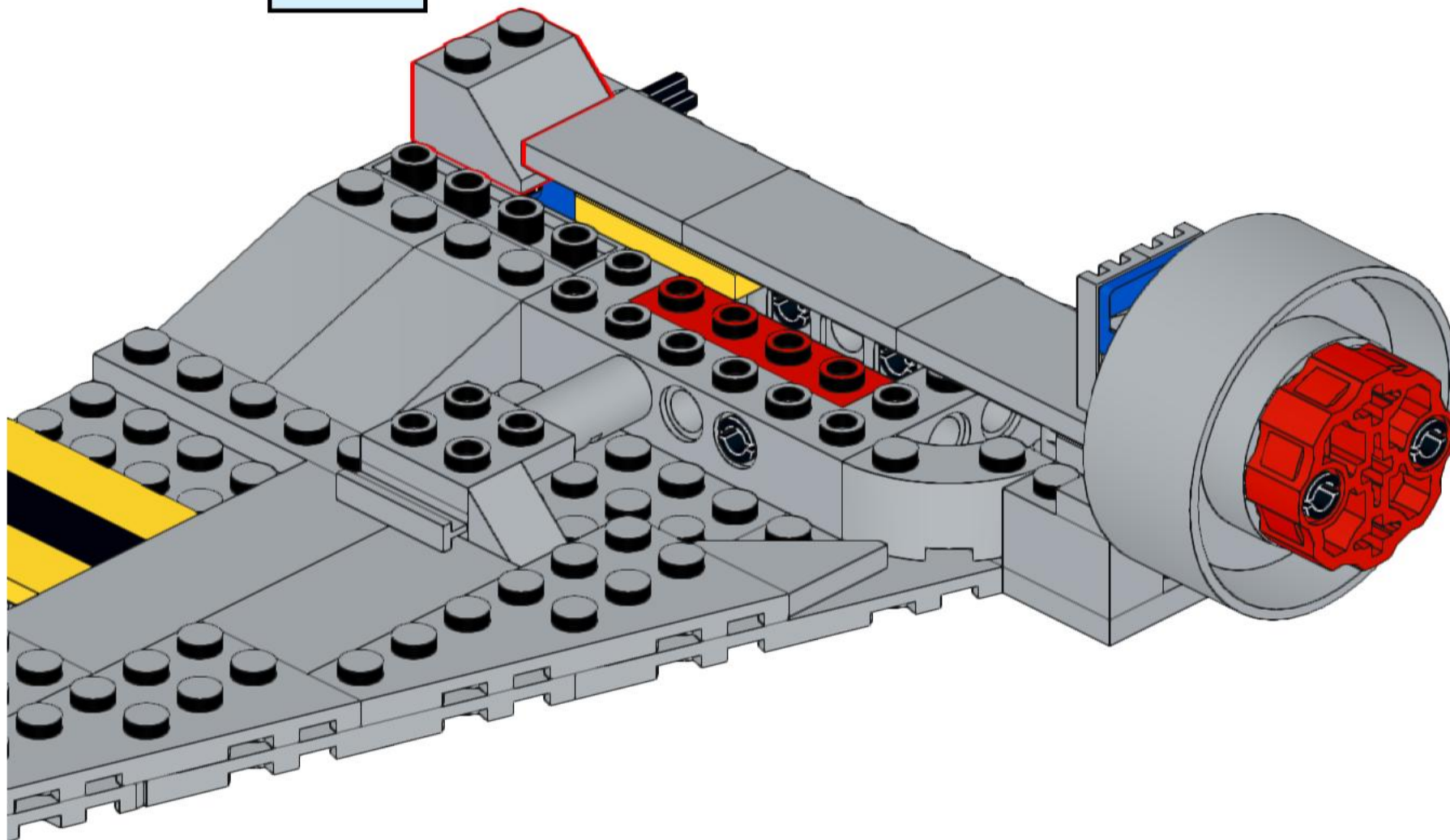
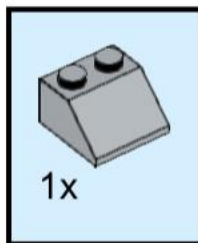

460

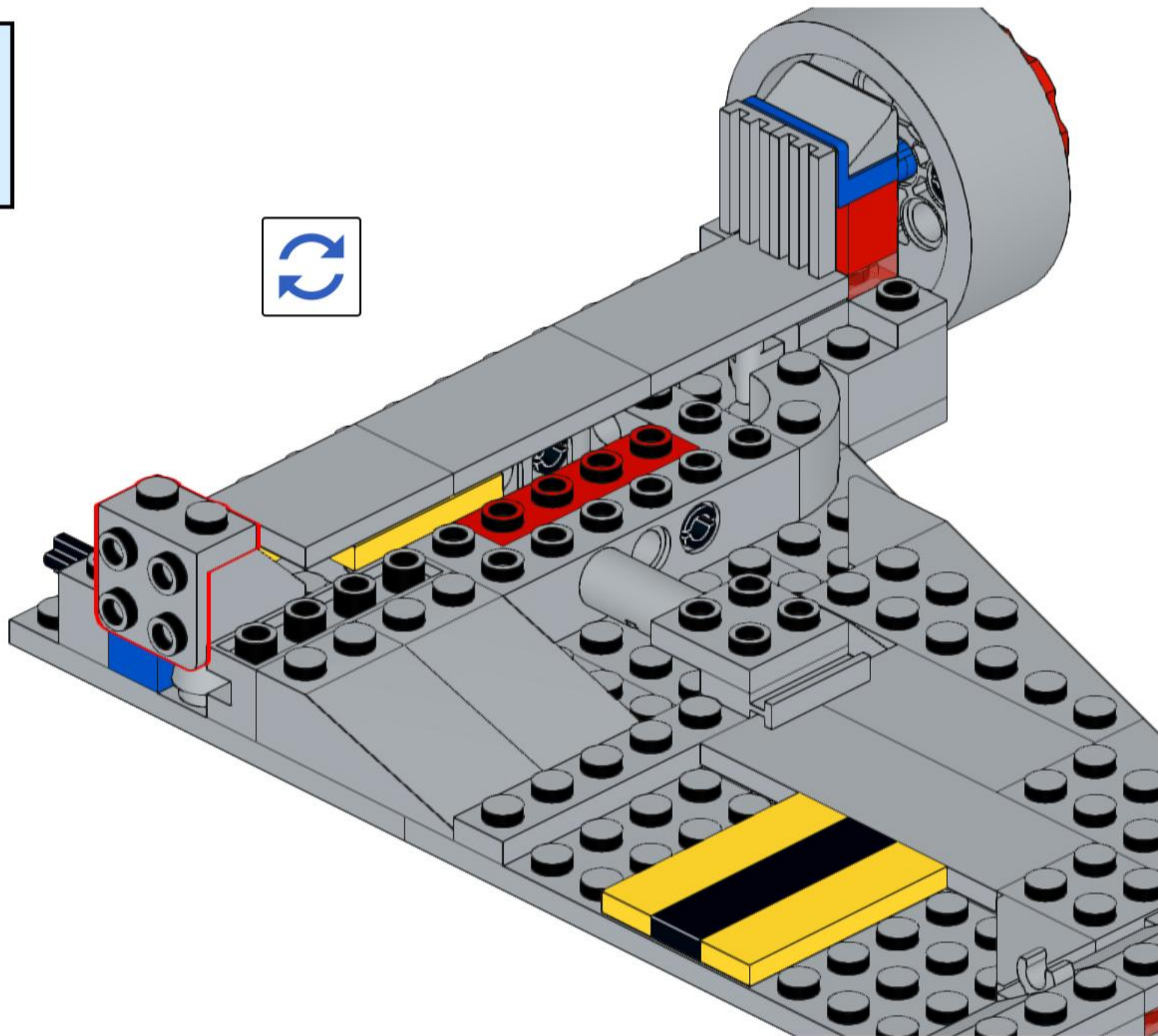
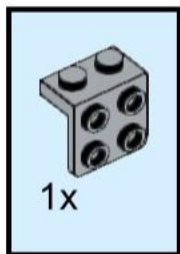

461

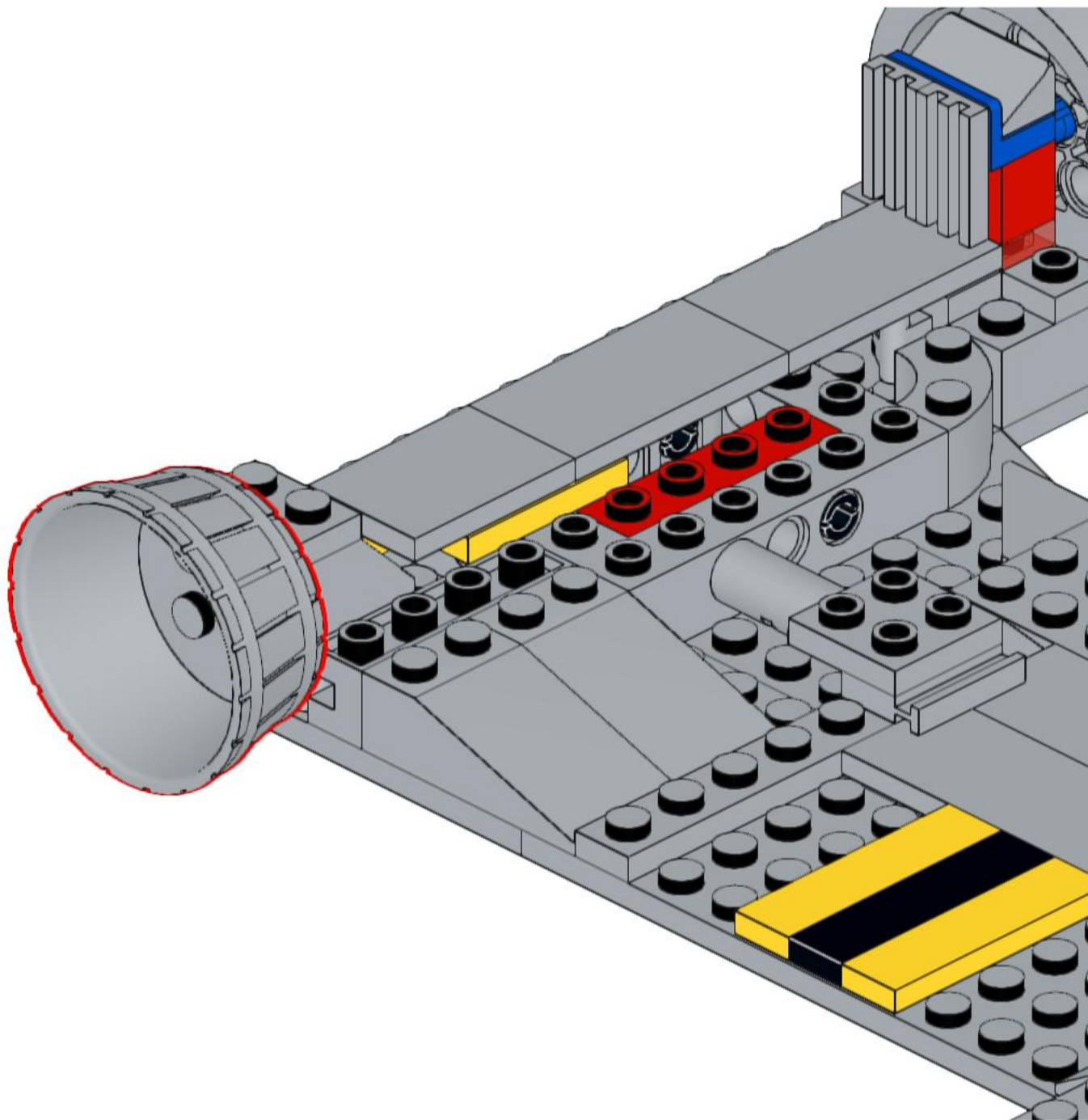
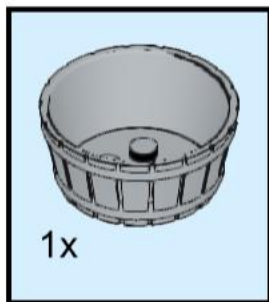

462

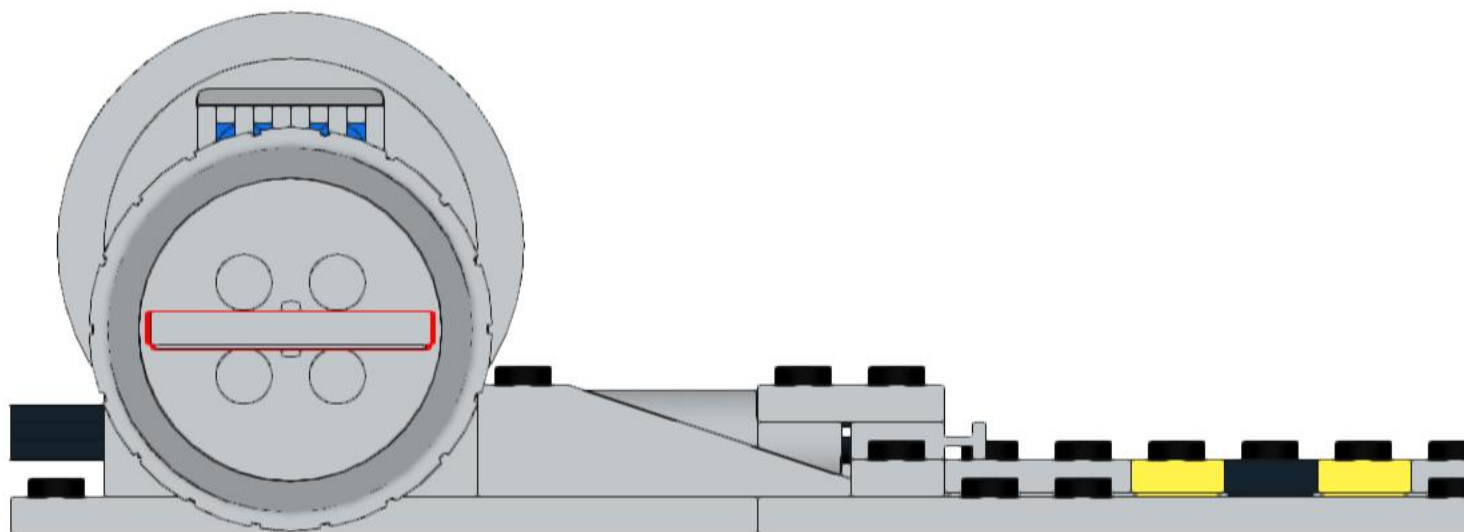
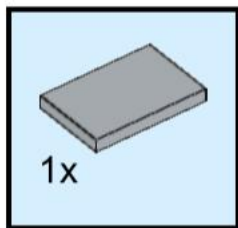

463

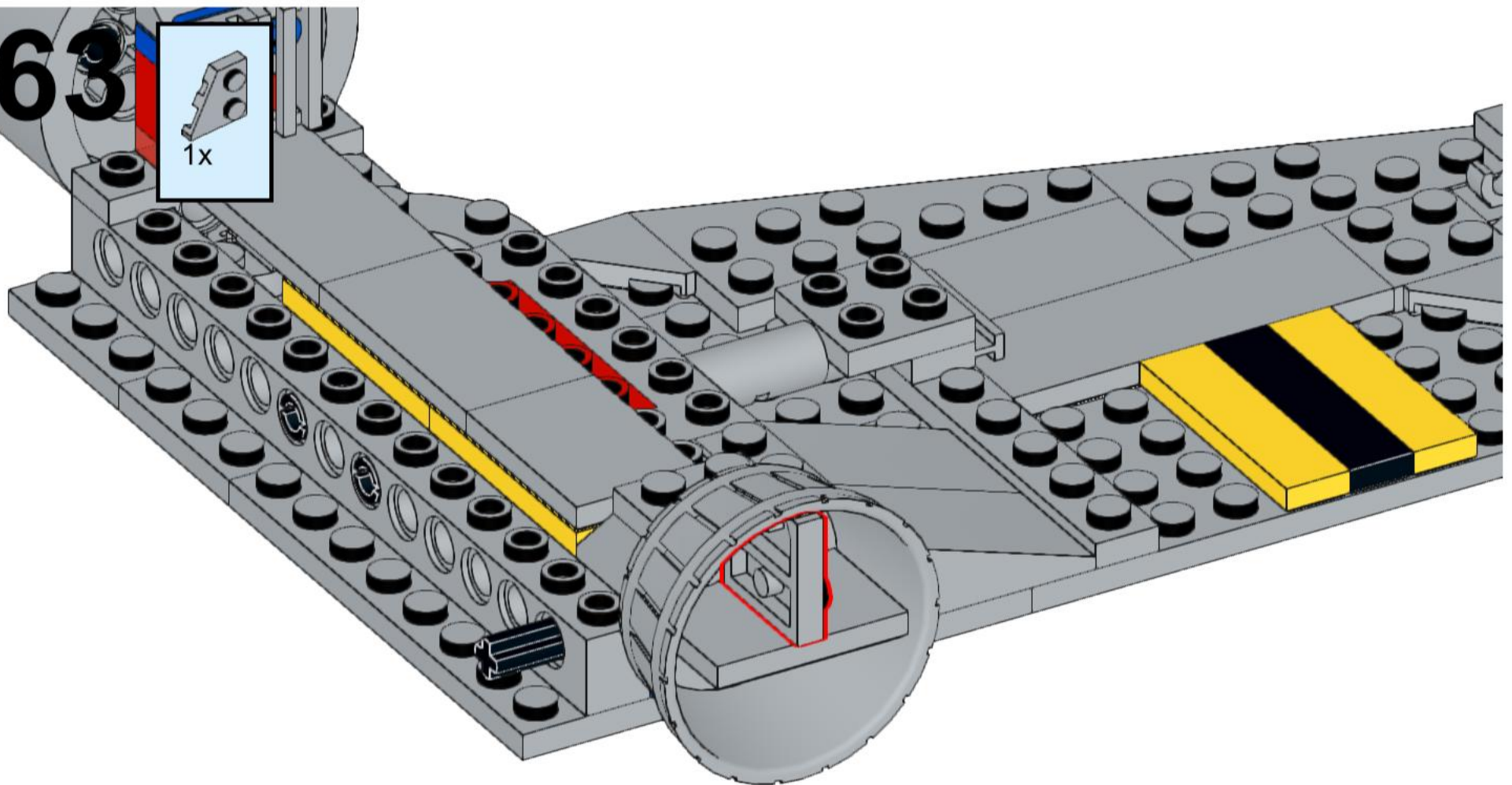
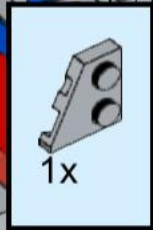

464

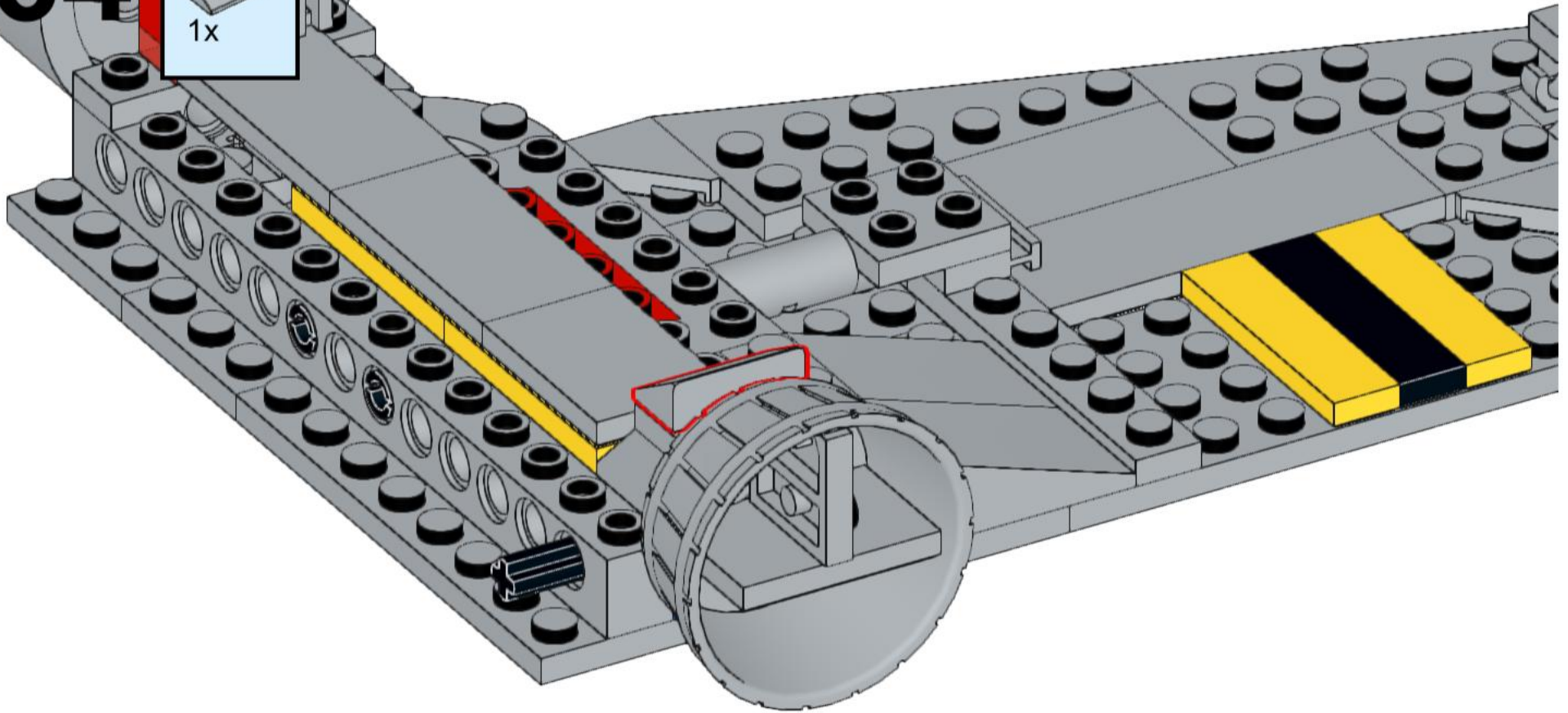
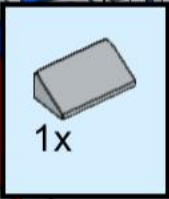

465

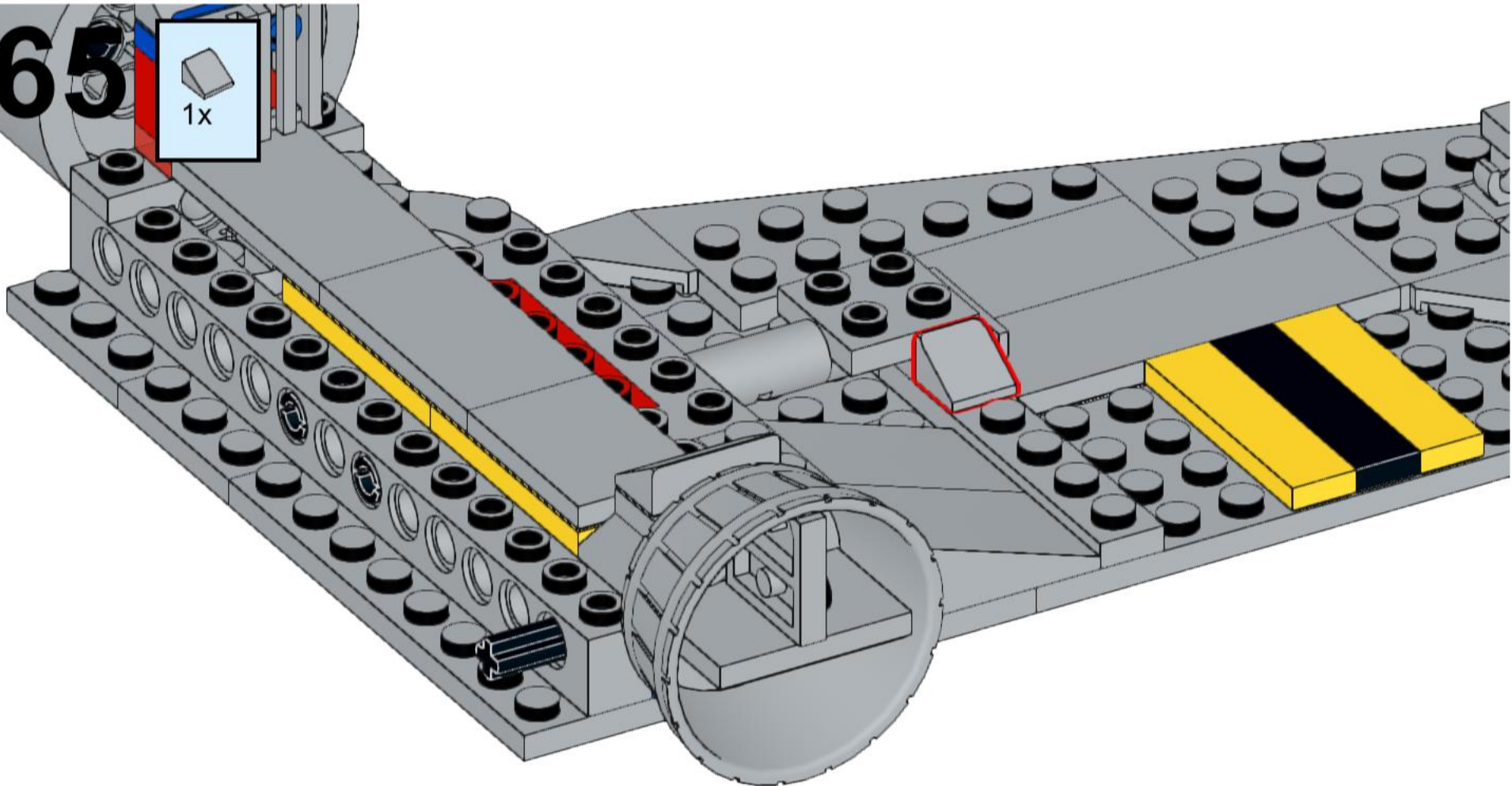
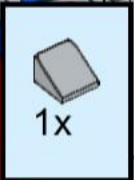

466

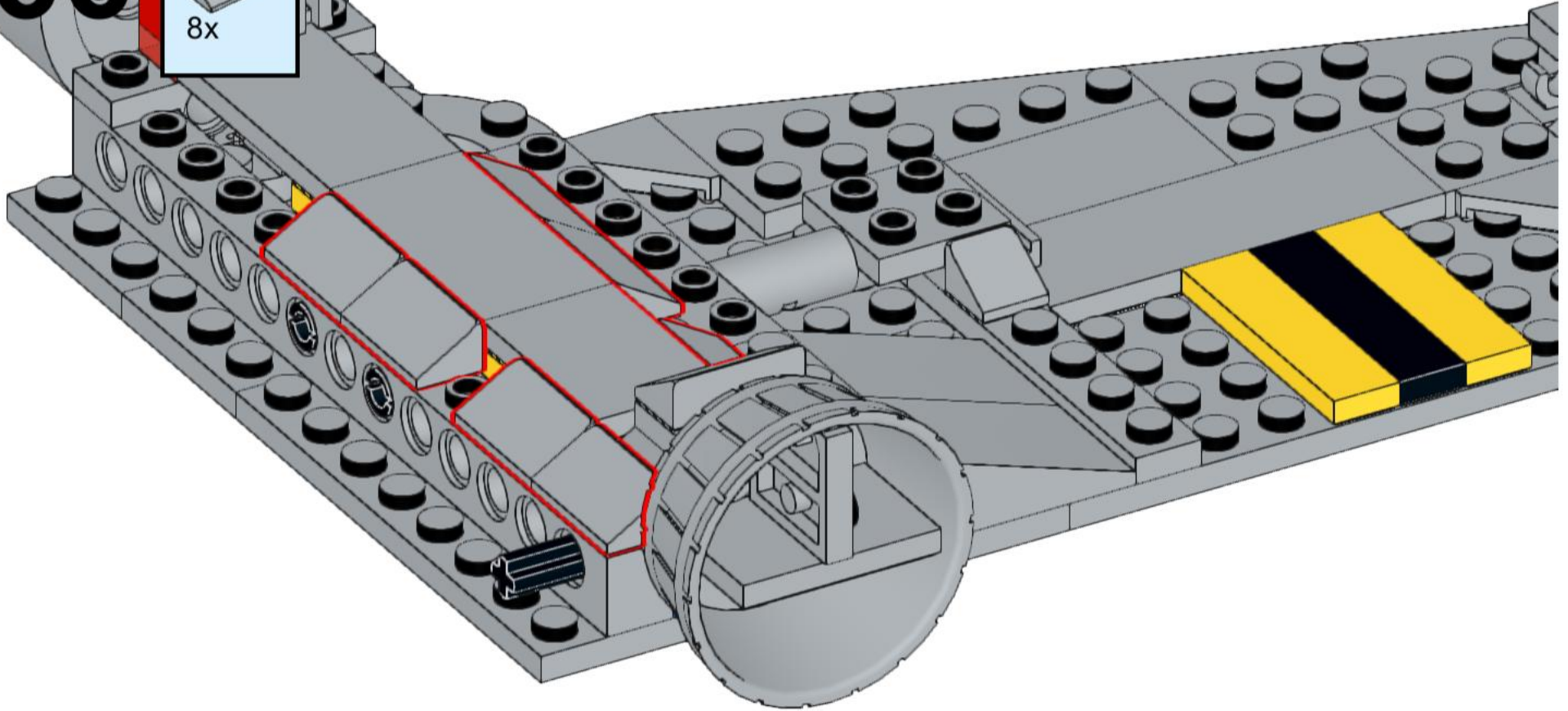
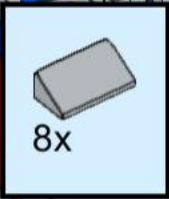

467

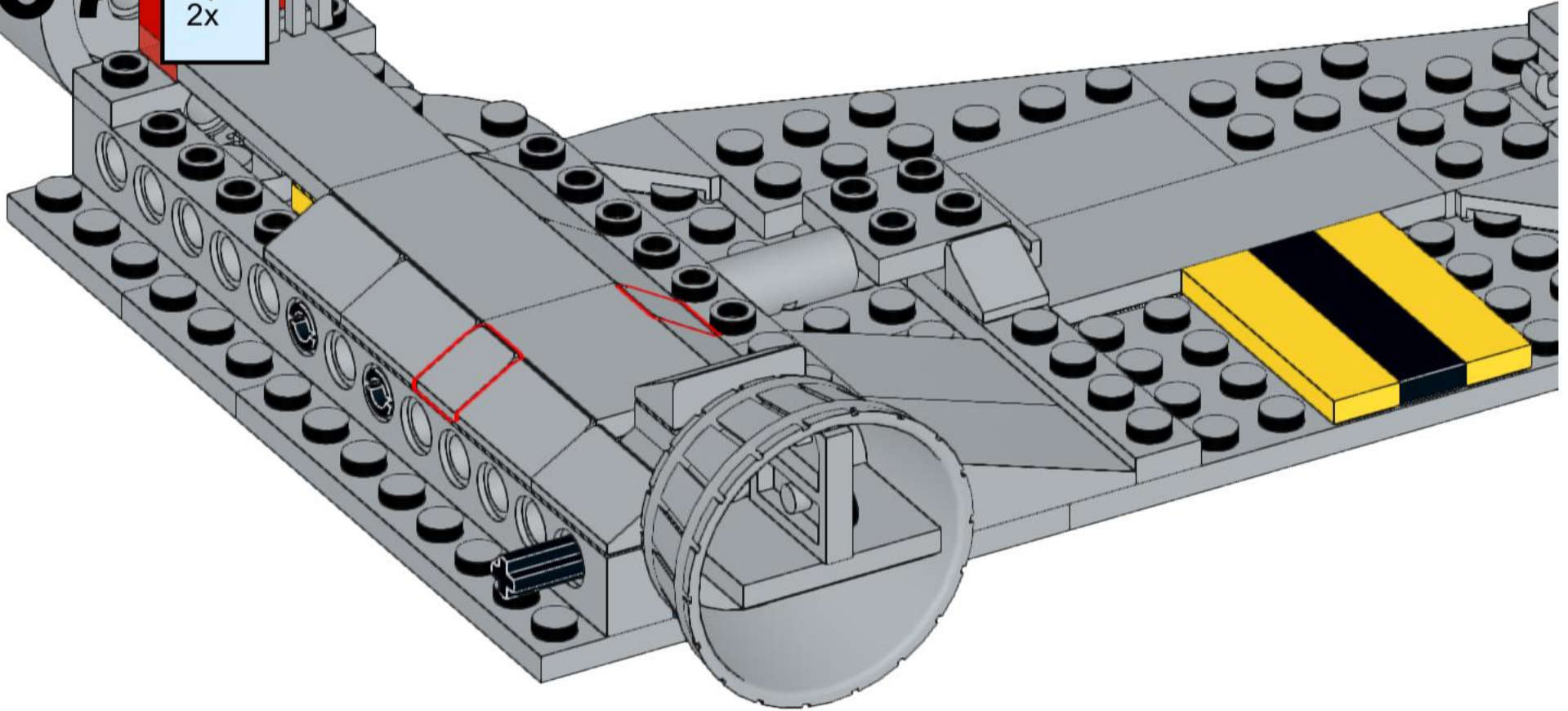
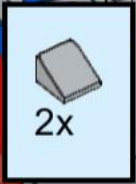

468

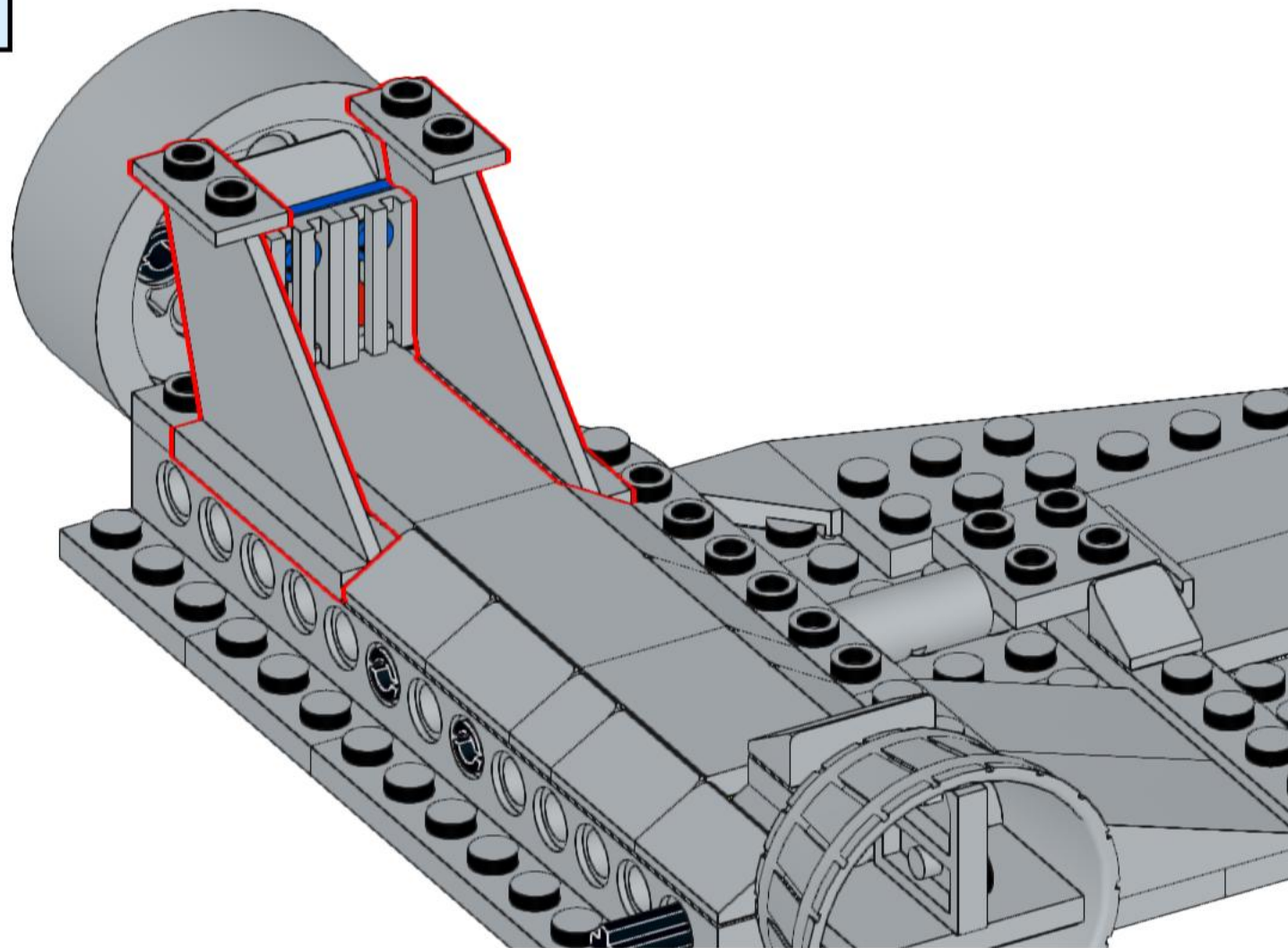
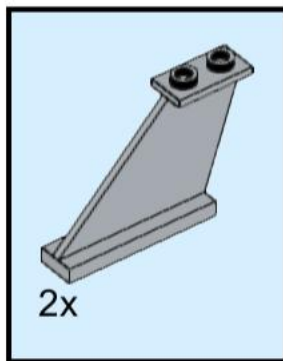

469

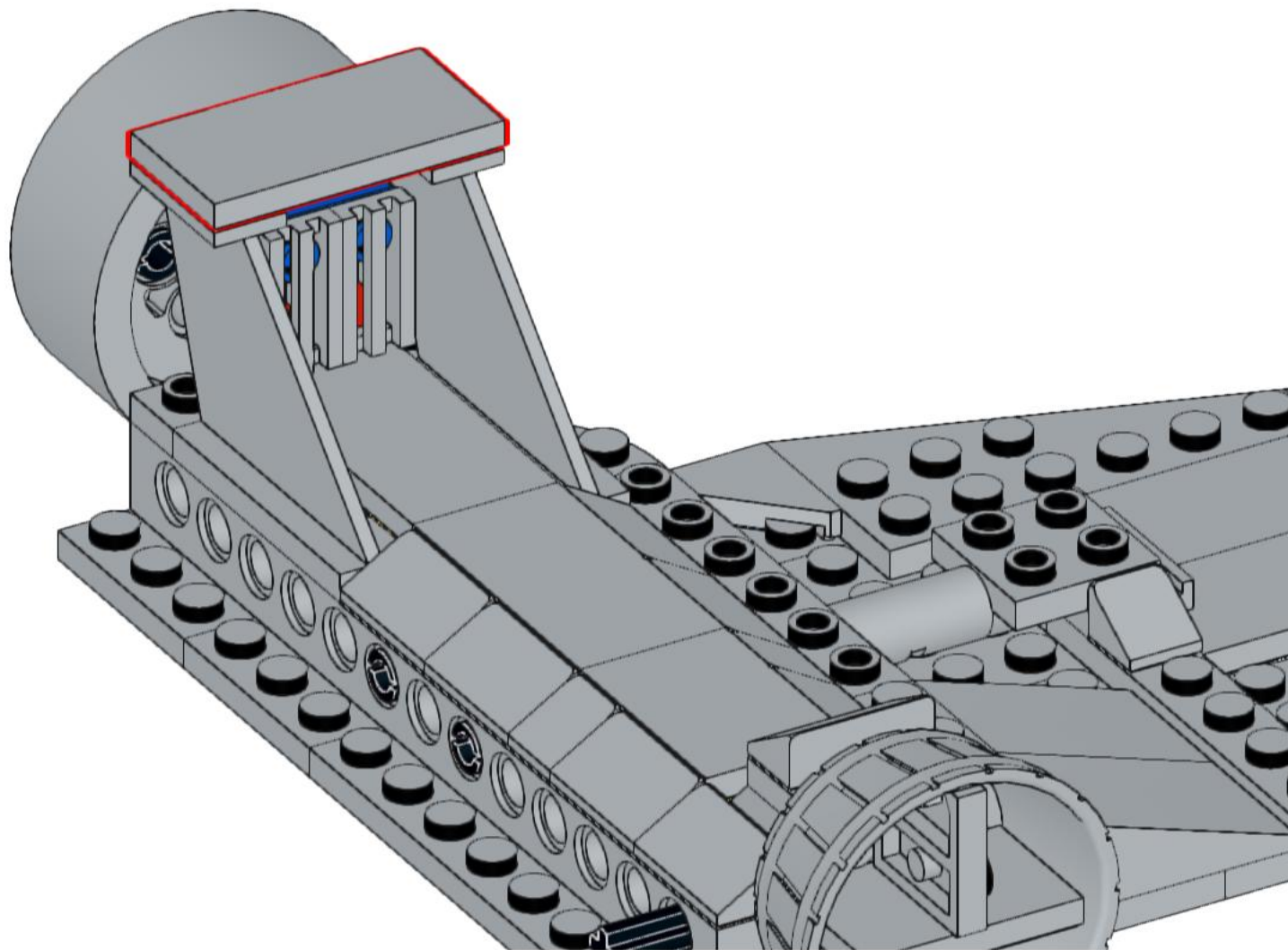
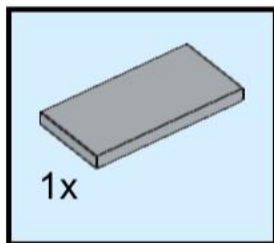

470

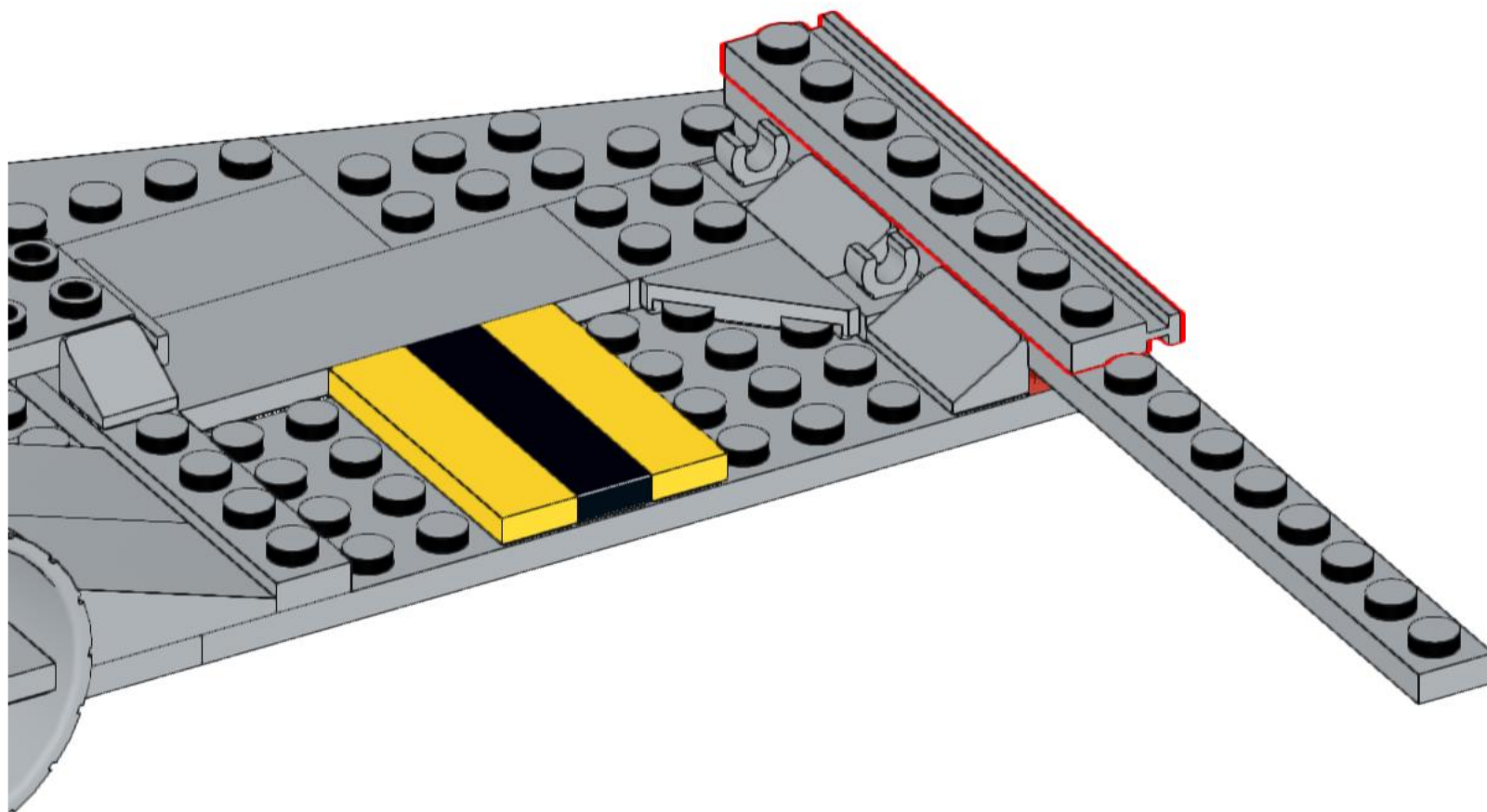
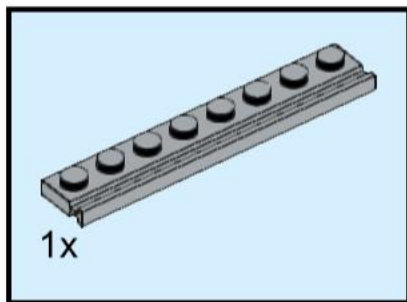

471

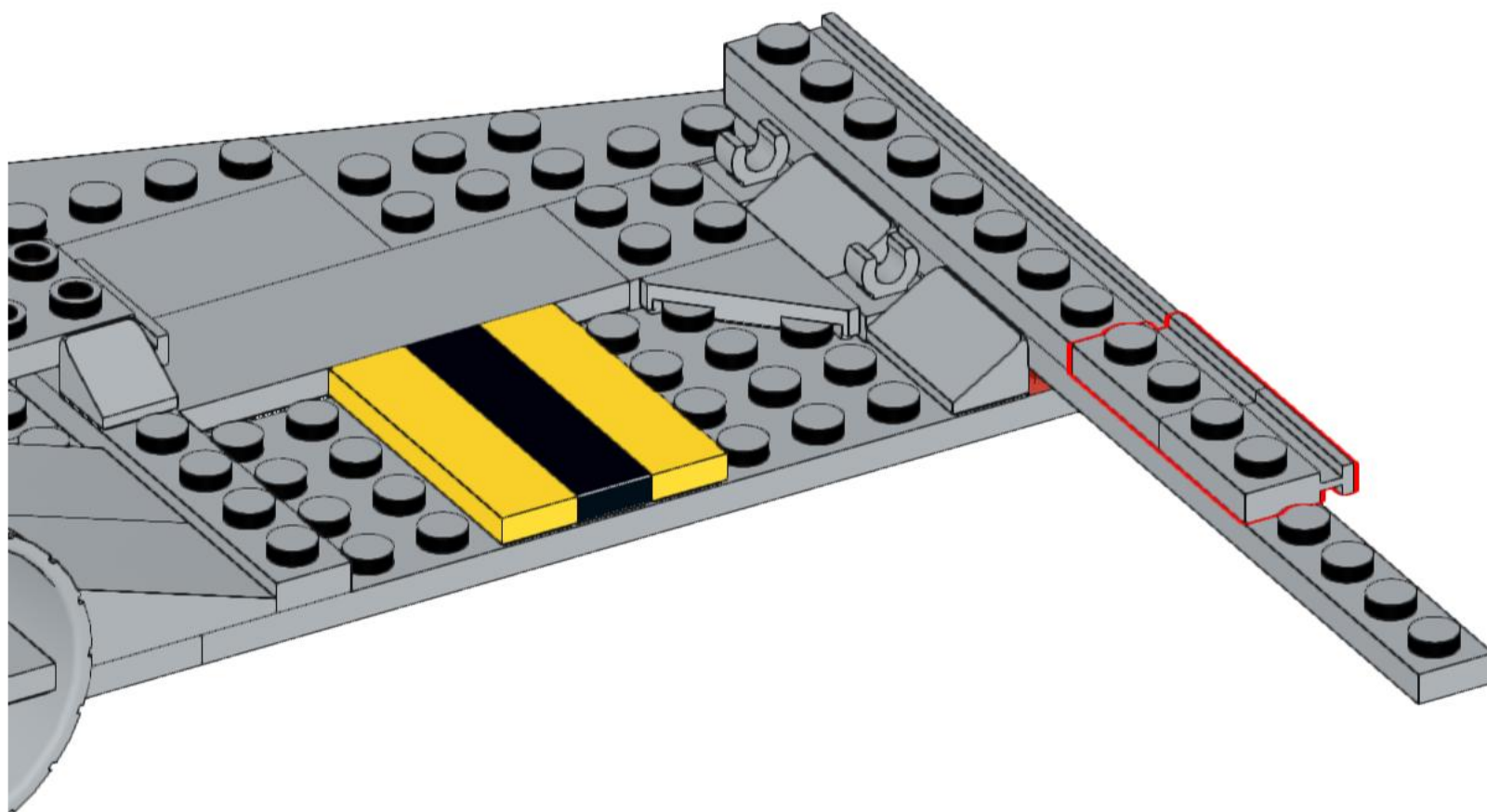
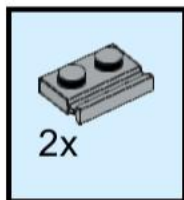

472

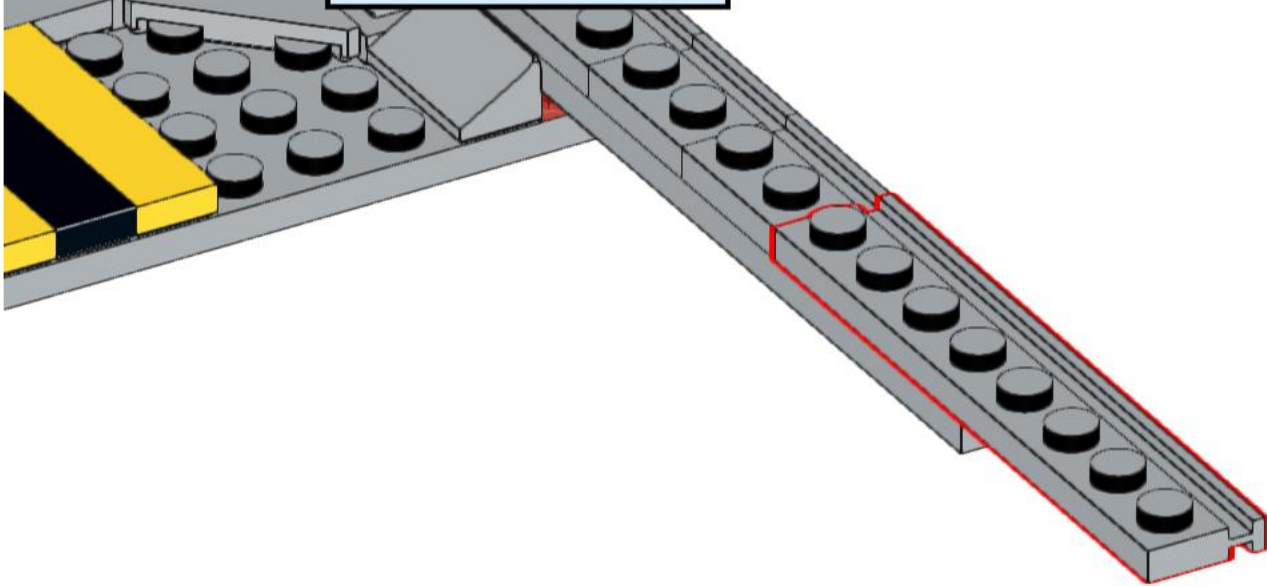
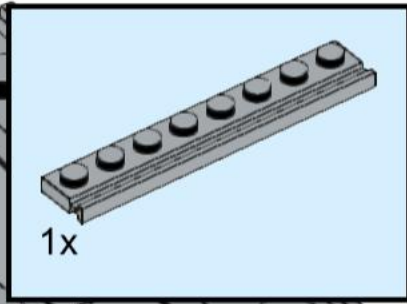

473

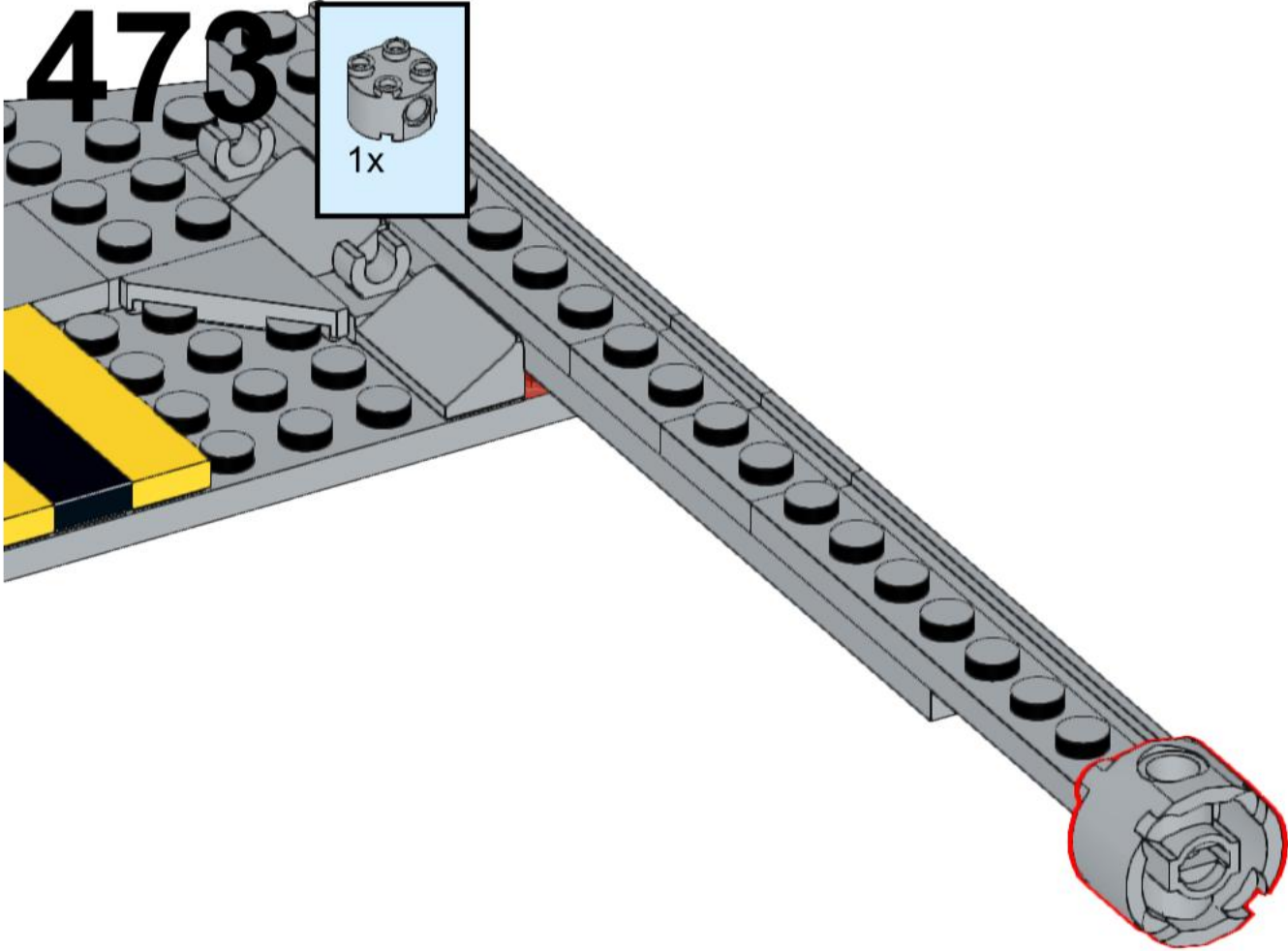
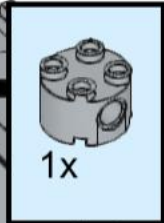

474

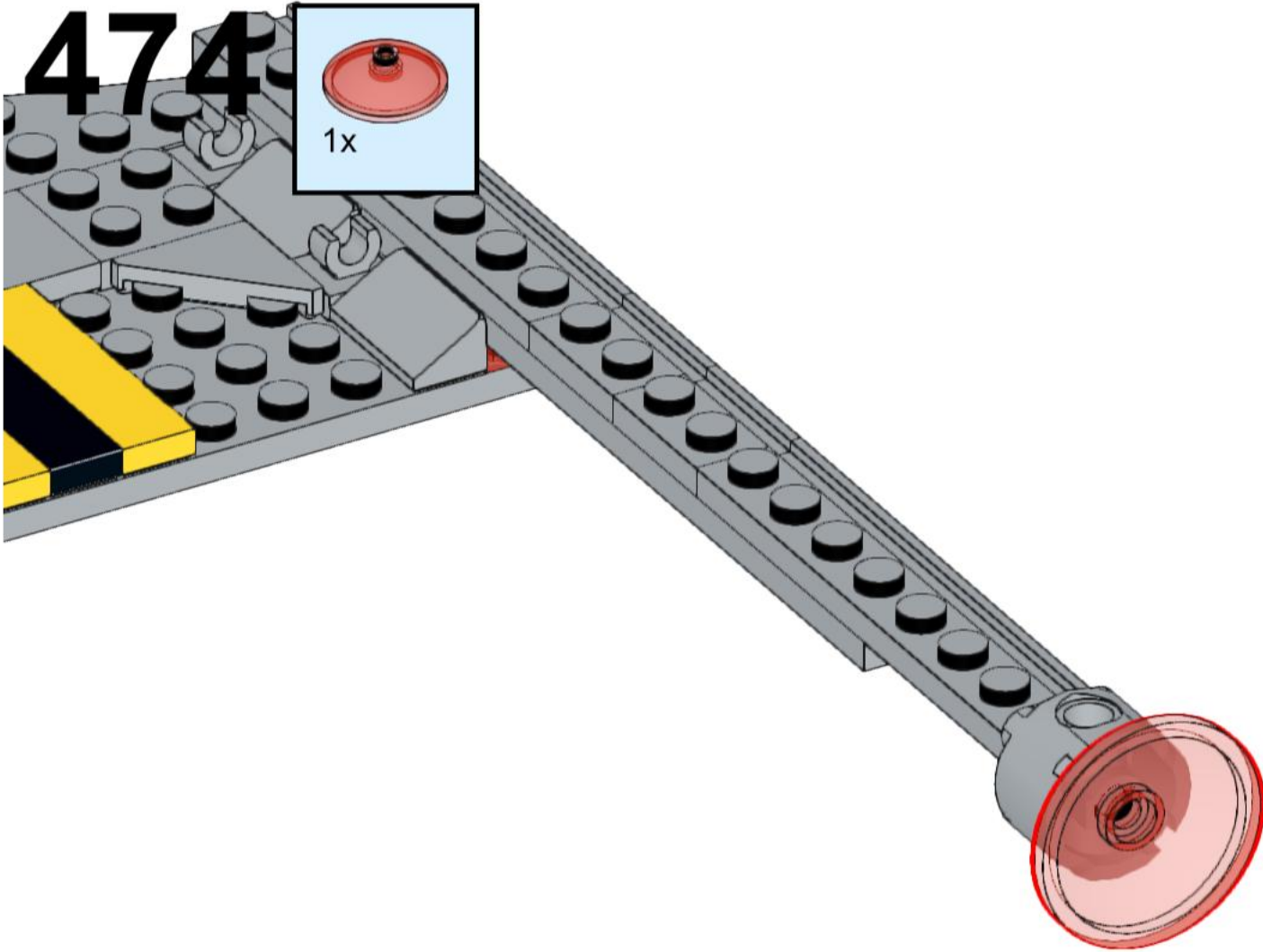
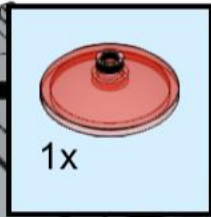

475

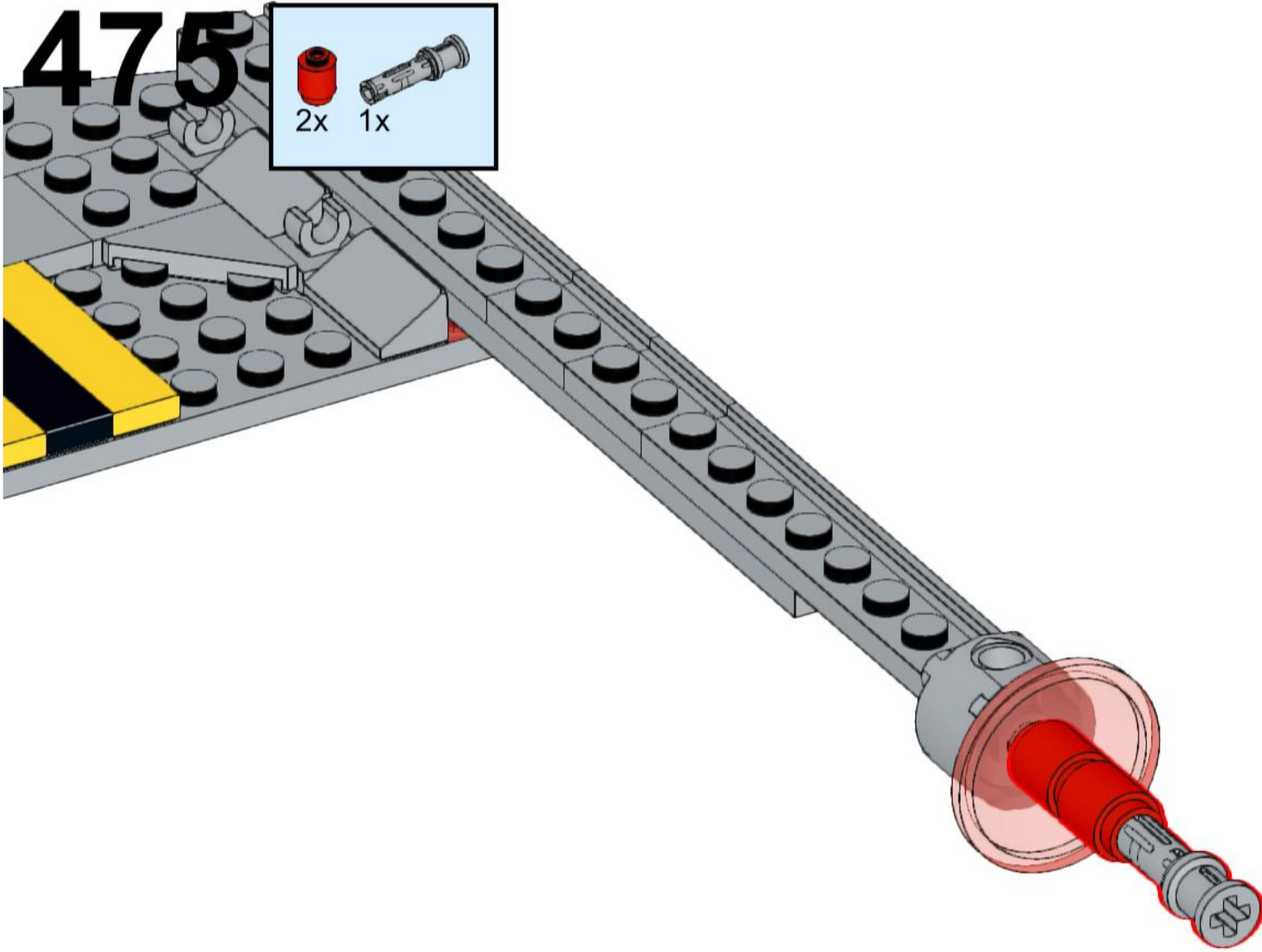
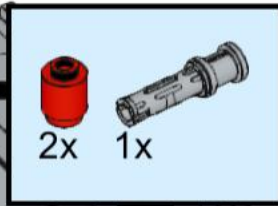

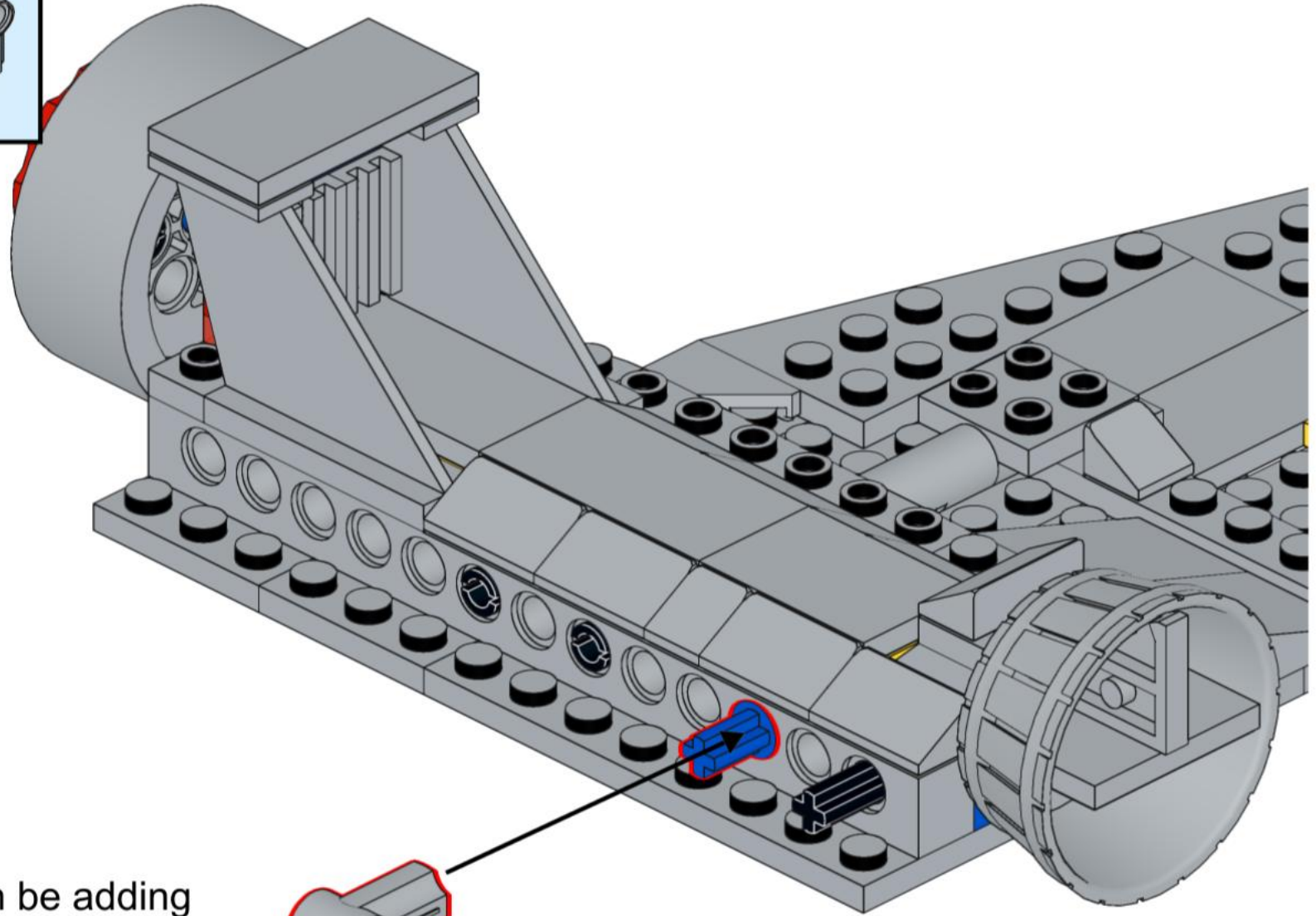
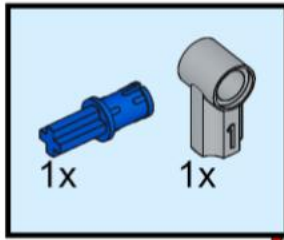

We will again be adding these two pieces to only one of the wings, the wing that will go on top.

476

